

BULLETIN 273B  
VOL 1

TECHNICAL MANUAL  
32 AND 33  
TELETYPEWRITER SETS  
KEYBOARD SEND-RECEIVE (KSR)  
RECEIVE-ONLY (RO)  
AUTOMATIC SEND-RECEIVE (ASR)

CONTENTS

DESCRIPTION  
DISASSEMBLY AND REASSEMBLY  
INSTALLATION  
LUBRICATION  
PRINCIPLES OF OPERATION

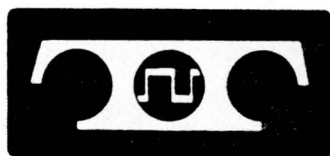

**TELETYPE<sup>®</sup>**  
CORPORATION

5555 TOUHY AVENUE, SKOKIE, ILLINOIS

## VOLUME 1

## INTRODUCTION

Bulletin 273B is a technical manual that provides general and specific information about the 32 and 33 Keyboard Send-Receive (KSR), Receive-Only (RO), and Automatic Send-Receive (ASR) Teletypewriter Sets and their component units. It consists of two volumes.

Volume 1 contains a description of the 32 and 33 Teletypewriter Sets and gives installation instructions. Also included in Volume 1 is information on the disassembly and reassembly, lubrication, and principles of operation of the component units of the Teletypewriter Sets. Volume 2 includes adjustment information on all component units of 32 and 33 Teletypewriter Sets.

Each volume is made up of a group of appropriate independent sections. Each independent section is complete within itself — it is separately identified by a title and section number, and the pages are numbered consecutively.

Each individual section is identified by a 9-digit section number which appears at the top of each page of a section. The section number appears on the left corner of left-hand pages and on the right corner of right-hand pages. In addition, the section number on the first page contains the suffix TC which identifies it as a Teletype Corporation section. All sections are placed in the technical manual in ascending numerical order.

To locate specific information, refer to the table of contents on the following page. In the first column, under "Equipment," find the name of the component unit or set in question. Move across the page to the second column and locate the title being sought. The applicable 9-digit section number can then be found in the third column. Turn to Page 1 of the applicable section, and the contents of that section will be found.

FILING INSTRUCTIONS

1. The following filing instructions apply to changes sent to the field.
2. Asterisks (\*) in the table of contents indicate changes.
3. When the issue of a section changes, replace the old issue with the attached new one.
4. In the case of addendums, turn to the affected section and follow the instructions on the first page of the attached addendum.
5. Replace the old table of contents with this new one.

## VOLUME 1

## TABLE OF CONTENTS

<u>Equipment</u>	<u>Title</u>	<u>Section</u>	<u>Issue</u>
Teletypewriter Set	Description	574-100-102	1
Teletypewriter Set	Installation	574-100-201	3
Keyboard	Principles of Operation	574-121-100	1
Keyboard	Lubrication	574-121-701	1
Keyboard	Disassembly and Reassembly	574-121-702	1
Typing Unit	Principles of Operation	574-122-100	1
Typing Unit	Lubrication	574-122-701	1
Typing Unit	Disassembly and Reassembly	574-122-702	1
Call Control Unit	Principles of Operation	574-123-101	2*
Tape Reader	Principles of Operation	574-124-100	1
Tape Reader	Lubrication	574-124-701	1
Tape Reader	Disassembly and Reassembly	574-124-702	1
Tape Punch	Principles of Operation	574-125-100	1
Tape Punch	Lubrication	574-125-701	1
Tape Punch	Disassembly and Reassembly	574-125-702	1
Cover	Adjustments, Lubrication, and Disassembly and Reassembly	574-126-100	1

32 AND 33 TELETYPEWRITER SETS

DESCRIPTION

CONTENTS	PAGE
1. GENERAL . . . . .	1
2. TELETYPEWRITER SETS . . . . .	2
KEYBOARD SEND-RECEIVE (KSR) TELETYPEWRITER SETS . . . . .	2
RECEIVE-ONLY (RO) TELETYPEWRITER SETS . . . . .	3
AUTOMATIC SEND-RECEIVE (ASR) TELETYPEWRITER SETS . . . . .	3
ACCESSORIES . . . . .	3
3. COMPONENTS . . . . .	6
KEYBOARD . . . . .	6
A. KSR and ASR Keyboard . . . . .	6
B. RO Keyboard . . . . .	9
TYPING UNIT . . . . .	9
MOTOR AND DRIVE PARTS . . . . .	12
CALL CONTROL UNIT . . . . .	12
COVER AND SUBBASE . . . . .	15
TAPE READER . . . . .	15
TAPE PUNCH . . . . .	16
4. TYPICAL APPLICATIONS . . . . .	17
5. TECHNICAL DATA . . . . .	18

1. GENERAL

1.01 This section is issued to provide a brief description of the 32 and 33 Teletypewriter Sets, together with principal components

and available accessories. The section describes typical applications and gives pertinent technical data. Also, the section is issued to present the information in a separate section.

1.02 The 32 and 33 Teletypewriter Sets described herein are electromechanical apparatus that provide terminal facilities for exchanging recorded communication via appropriate transmission facilities, including telegraph lines, telephone networks, and radio channels.

1.03 References to the "left," "right," "up," "down," "front," or "rear," etc consider the Teletypewriter Set to be viewed from a position where the keyboard cover faces the viewer, with the platen knob to the viewer's left.

1.04 The following Teletypewriter Sets are covered:

- (a) Keyboard Send-Receive (KSR) Teletypewriter Set (Figure 1).
- (b) Receive-Only (RO) Teletypewriter Set (Figure 2).
- (c) Automatic Send-Receive (ASR) Teletypewriter Set (Figures 3 and 4).

1.05 Transmission and reception are effected by a start-stop signaling code which is carried by the transmission facilities. The basic difference between the 32 and 33 Teletypewriter Sets is that the former utilizes a 5-level code and the latter utilizes an 8-level code. (See the appropriate section for an explanation of codes.) The Teletypewriter Set will operate at speeds up to 100 words per minute (wpm).

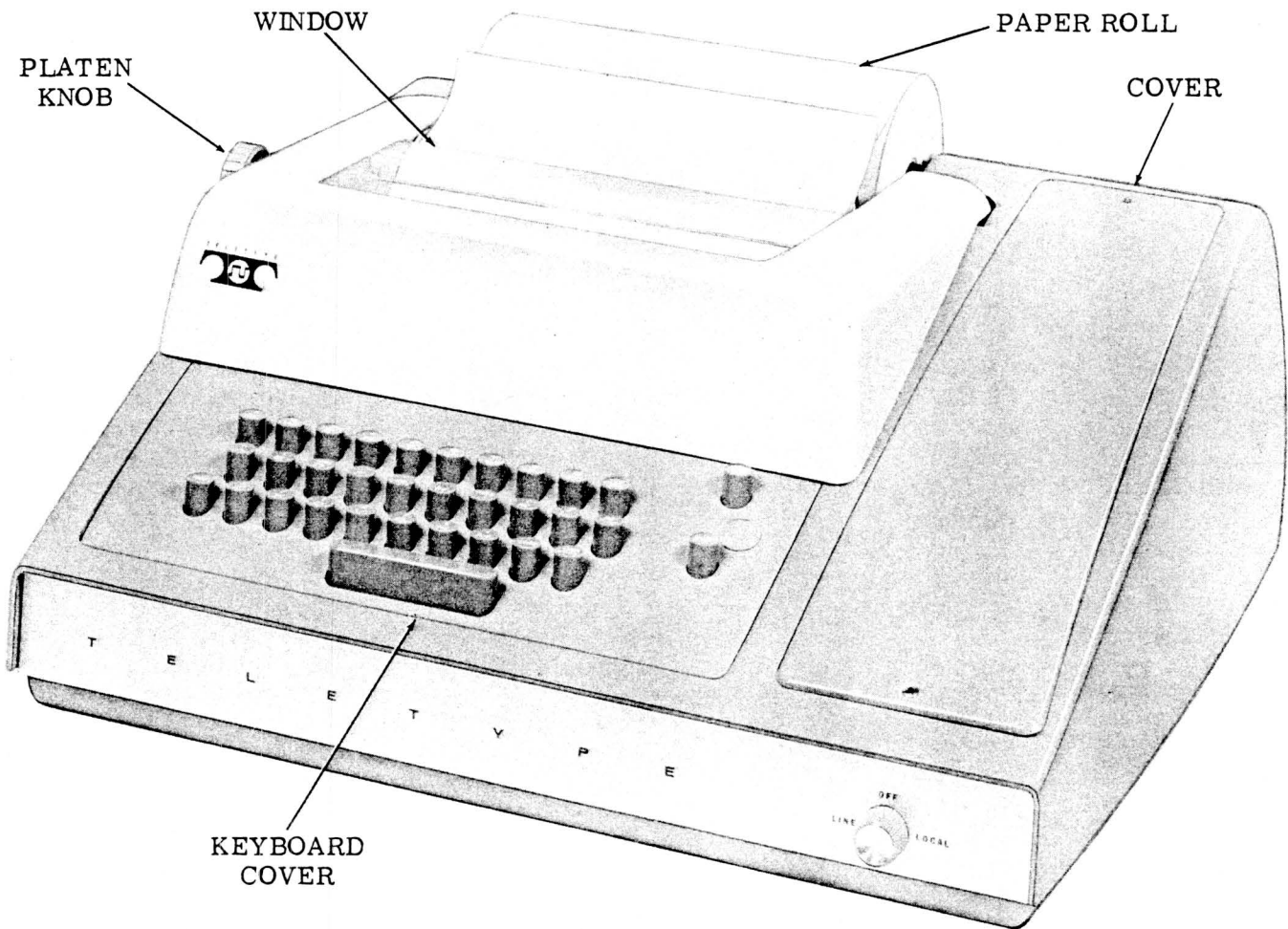

(RIGHT FRONT VIEW)

Figure 1 — Keyboard Send-Receive (KSR) Teletypewriter Set

2. TELETYPEWRITER SETS

KEYBOARD SEND-RECEIVE (KSR) TELETYPEWRITER SETS (Figure 5)

2.01 The KSR provides facilities for originating messages for transmission by the manual operation of a keyboard, and for receiving and printing messages, whether originated locally or remotely, on page-width copy paper.

2.02 The basic KSR consists of the following major components (Figures 1 and 5) which are described in the indicated paragraphs:

COMPONENT

PARAGRAPHS

Keyboard	3.01 - 3.04
Typing Unit	3.05 - 3.06
Motor	3.07 - 3.08
Call Control Unit	3.09 - 3.11
Cover	3.12
Subbase	3.13

2.03 The keyboard, typing unit, and call control unit are mounted on the subbase (Figure 5). The motor is mounted on the typing unit base casting. The cover encloses the other components and is attached to the subbase.

On friction feed Teletypewriter Sets, paper feeds from a roll at the rear and is led around a platen, where it is printed. On sprocket feed Teletypewriter Sets, forms normally feed from the forms' original container at the rear, under a paper roll spindle, and around a platen, where they are printed. A window permits viewing the printed copy. Facilities are provided for connecting the KSR to an ac power source and the transmission facilities.

2.04 The 32 KSR has a 3-row keyboard (Figure 6) and uses a 5-level start-stop signaling code. The 33 KSR has a 4-row keyboard (Figure 7) and uses an 8-level start-stop signaling code.

#### RECEIVE-ONLY (RO) TELETYPEWRITER SETS (Figure 2)

2.05 The RO provides facilities for receiving messages and printing them on page-width copy paper.

2.06 The basic RO consists of the same components as the KSR, listed in 2.02 above. However, the keyboard is blank and has no facilities for transmission. Paragraph 2.03 above also applies to the RO.

2.07 The 32 RO uses a 5-level start-stop signaling code, and the 33 RO uses an 8-level start-stop signaling code.

#### AUTOMATIC SEND-RECEIVE (ASR) TELETYPEWRITER SETS (Figures 3 and 4)

2.08 The ASR provides facilities for originating messages for transmission by either the manual operation of a keyboard or the reading of perforated paper tape. They provide facilities for recording messages, whether originated locally or remotely, by perforating them in tape and/or printing them on page-width copy paper. The ASR may be used in the following ways:

- (a) To transmit messages from the keyboard while making a printed page copy with or without perforating tape.
- (b) To receive messages from line and print them on page copy with or without perforating tape.
- (c) To locally perforate messages in tape from keyboard for later transmission while making a printed page copy.

(d) To transmit messages from tape while making a page copy with or without perforating tape.

2.09 The basic ASR includes the same components as the KSR listed in 2.02 above. Paragraphs 2.03 and 2.04 above also apply to the ASR. In addition, they have a tape reader (3.14 - 3.15) and a tape punch (3.16 - 3.18).

2.10 The tape punch and tape reader are mounted on the left side of the ASR. The tape feeds forward from a roll into the tape punch, where it is perforated. It can then be fed into the tape reader for transmission. Controls are provided for the tape punch and tape reader. A removable metallic chad container collects the paper (chad) punched out of the perforations in the tape.

#### ACCESSORIES

2.11 A number of optional accessories are available with the equipment, including the following:

- (a) A sheet metal stand (Figure 3), which will support the subbase and components at a convenient operating level. It consists of chrome feet, equipped with leveling screws, and an enclosure to house auxiliary apparatus, such as a data set and the tape reader power pack. A removable rear panel provides access to the enclosure. If desirable, the feet of the stand may be bolted to the floor.
- (b) A copy holder with line guide (Figure 3).
- (c) Call control facilities, including buttons, indicator lamps, motor control relay, speaker, ringer, buzzer, and rotary, TOUCH-TONE, and card dialers.
- (d) Low-paper alarm.
- (e) An answer-back mechanism (see Figure 9) which will automatically identify a station by transmitting predetermined character sequences.
- (f) Optional functions, including unshift on space and automatic carriage return-line feed.

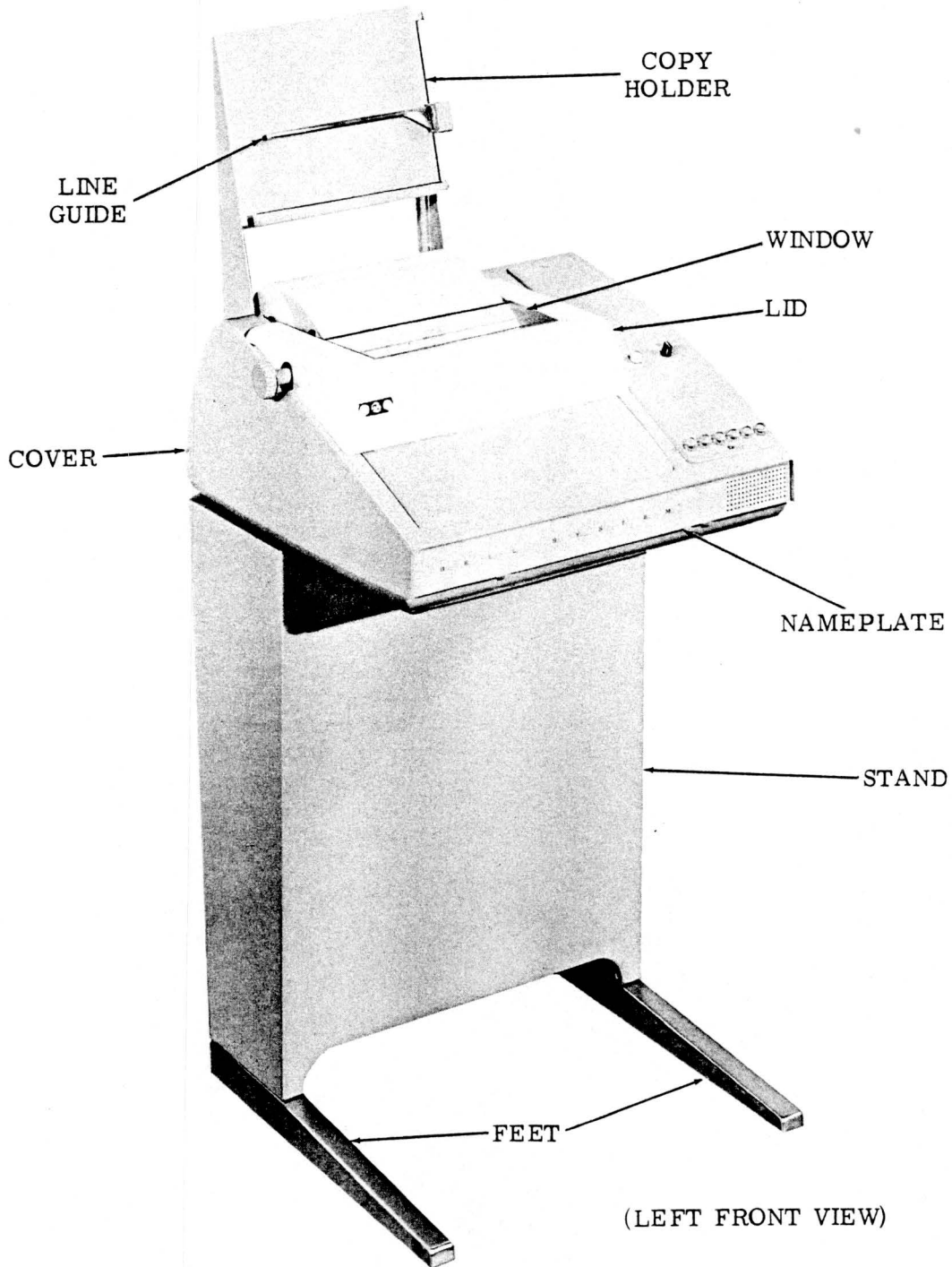

Figure 2 — Receive-Only (RO) Teletypewriter Set

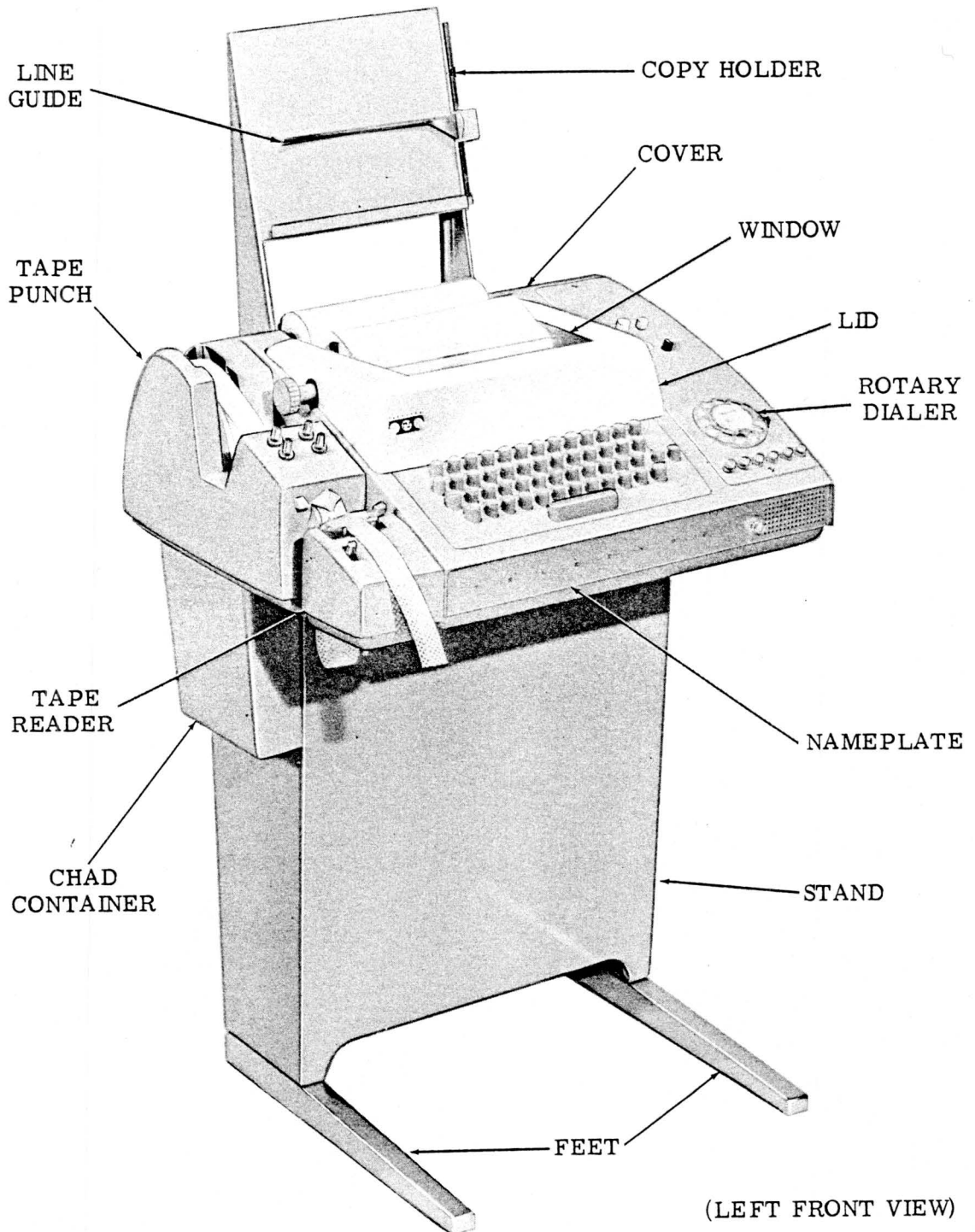

Figure 3 — Automatic Send-Receive (ASR) Teletypewriter Set

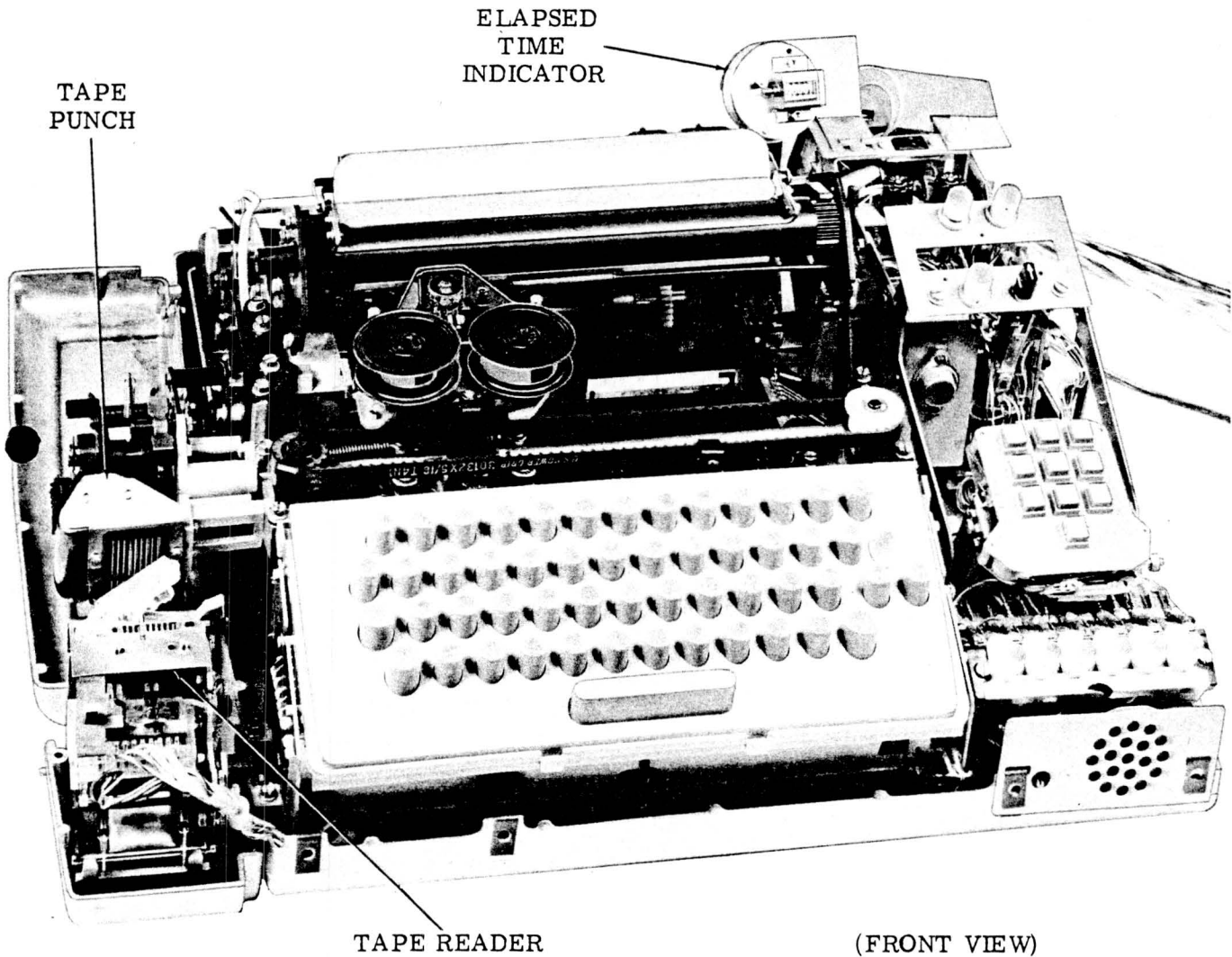

Figure 4 -- Automatic Send-Receive (ASR) Teletypewriter Set (Without Cover)

### 3. COMPONENTS

#### KEYBOARD (Figures 6 and 7)

##### A. KSR and ASR Keyboard

3.01 In conjunction with a distributor mechanism on the typing unit, the keyboard provides facilities for transmitting messages by the manual operation of a group of keys. It includes the following components:

- (a) A spacebar and keys similar to those on a typewriter.
- (b) A codebar mechanism which converts the manual depression of the keys to mechanical positions corresponding to the proper code combinations.

(c) A contact mechanism in which the codebar mechanism sets up the code combinations for conversion to start-stop signals by the distributor.

Note: A second contact mechanism is found on the left side of keyboards equipped to detect errors by the "even parity" method. (See Paragraph 3.03(a).)

(d) A frame and two side brackets which support the mechanisms and a cover which serves as a guide for the keys.

(e) A cable with connector which electrically interconnects the keyboard with the call control unit.

3.02 The 32 keyboard (Figure 6) has three rows of keys and generates a 5-level code that utilizes a letters-figures shift feature. To transmit the characters appearing on the lower part of keytops, the letters (LTRS) key must first be pressed. To transmit the characters on the upper part of the keytops, the figures (FIGS) key must first be pressed. Auxiliary keys such as line break (BREAK), repeat (REPT), and answer-back actuation (HERE IS) are located at the upper right of the three rows.

3.03 The 33 keyboard (Figure 7) is similar to the 32 in appearance, but more closely resembles a typewriter keyboard. It has four rows of keys and generates an 8-level code.

(a) Many 33 keyboards are equipped with an error detection feature called "even parity." Even parity provides for adding a

pulse whenever the number of marking pulses in a code combination is odd, and normally uses the eighth level for this purpose. The 33 keyboards which are not equipped with "even parity" will always have the eighth level marking.

(b) The characters on the lower part of the keytops, including the numerals in the upper row, can be transmitted without the use of a shift operation. A SHIFT key is used to transmit the printing characters (such as "&," "%," and "#") appearing on the upper part of the keytops.

Note: When the SHIFT key is held down, all the keys which do not print characters which appear on the upper part of the keytops are mechanically locked and cannot be operated. This prevents transmission of false characters for those keys blocked.

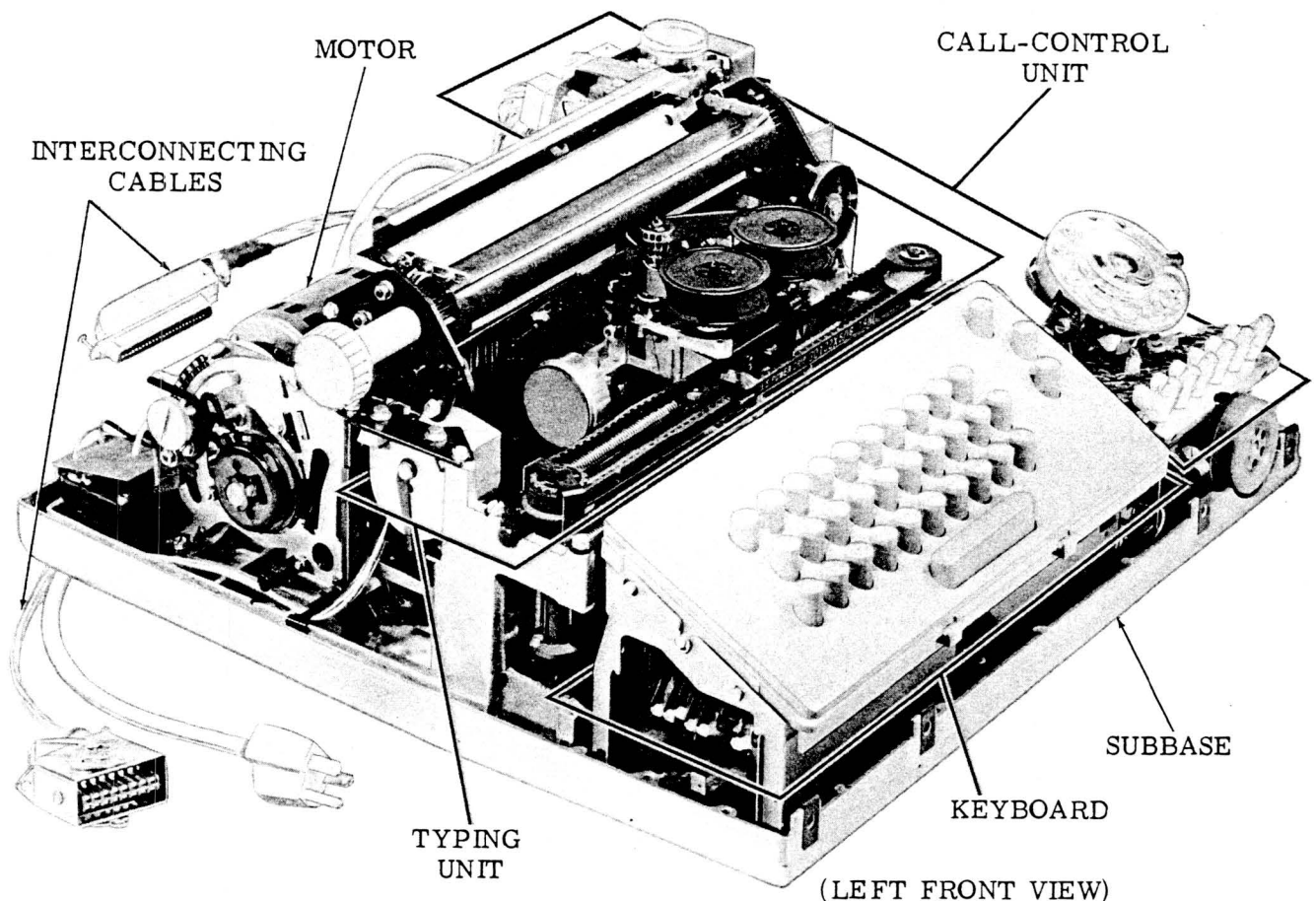

Figure 5 — Keyboard Send-Receive (KSR) Teletypewriter Set (Without Cover)

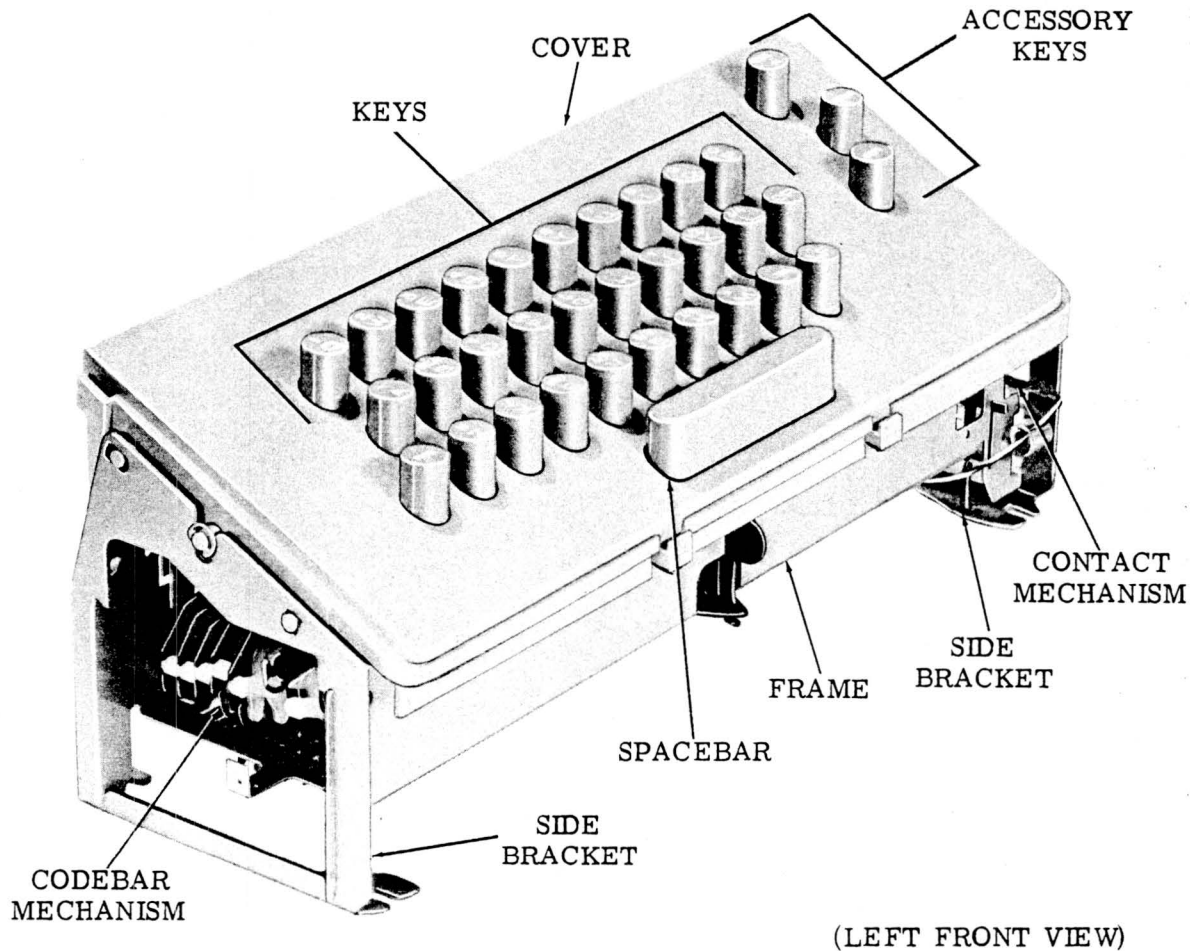

Figure 6 - 32 Keyboard

(c) A control (CTRL) key is used to transmit the control functions (such as WRU, BELL, and TAB) which appear on the upper keytops.

Note: When the CTRL key is held down on those keyboards equipped with "even parity," the sixth pulse codebar is shifted to its spacing position, and all keys with characters that normally have the no. 6 code element marking are mechanically locked and cannot be operated. This prevents the transmission of false characters for those keys blocked.

(d) Simultaneous use of both the CTRL and SHIFT keys allows access to special functions (such as "S<sub>5</sub>"). In every case, the SHIFT and/or CTRL keys must be held down while the appropriate character key is depressed.

(e) Because of the frequency of use, separate keys for certain functions, such as RE-TURN (carriage return) and LINE FEED are provided, and the CTRL key is not necessary to generate their code combinations. In the case of RE-TURN and LINE FEED, the CTRL key can be used in conjunction with either the RE-TURN or LINE FEED keys, but, for keyboards equipped with "even parity," parity is lost if the CTRL key is used.

Note: In addition to the separate key provided, the "line feed" code combination can be generated by the simultaneous use of the CTRL and J keys. Likewise, the "carriage return" code combination can be generated by the simultaneous use of the CTRL and M keys.

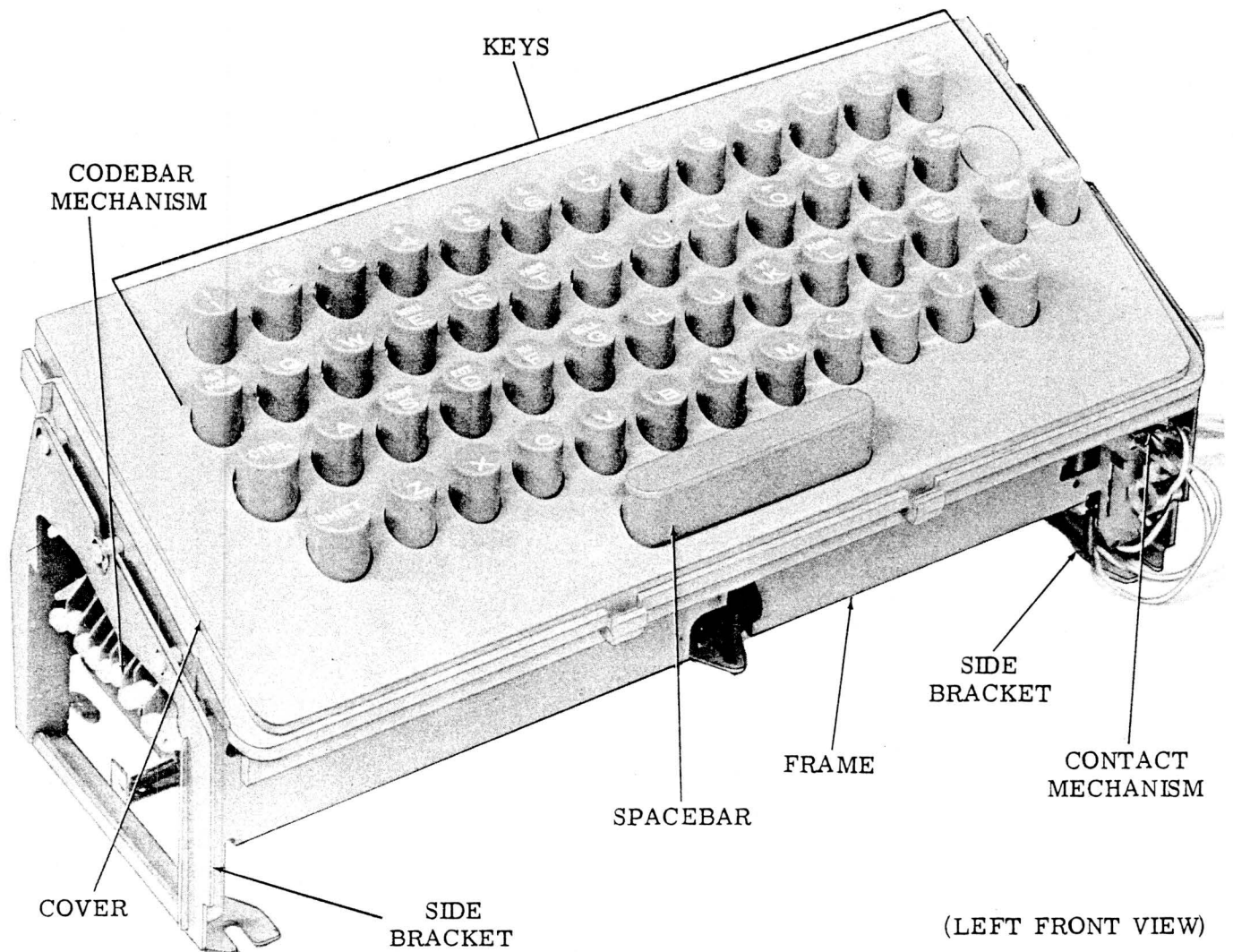

Figure 7 - 33 Keyboard

### B. RO Keyboard (Figure 2)

3.04 The RO keyboard has the frame and side brackets mentioned in 3.01(d) above. However, its cover is blank and has no facilities for transmission described in 3.02 and 3.03.

### TYPING UNIT (Figures 8 and 9)

3.05 The typing unit receives start-stop signals from the call control unit and uses them to control mechanical motions which print the messages, perform functions, and, in the case of the ASR, perforate tape.

3.06 The principal components of the typing unit include the following:

(a) A main shaft which receives motion from the drive parts and distributes it to the various mechanisms through three (four) internal expansion clutches.

Note: Friction feed typing units have three clutches. Sprocket feed typing units have four clutches.

(b) A selector mechanism which translates the start-stop signals to corresponding mechanical arrangements that control a codebar mechanism. A range finder permits the selector to be adjusted so as to sample the signals at the most favorable time.

(c) A codebar mechanism which controls printing, functions, and, in the case of the ASR, tape perforation.

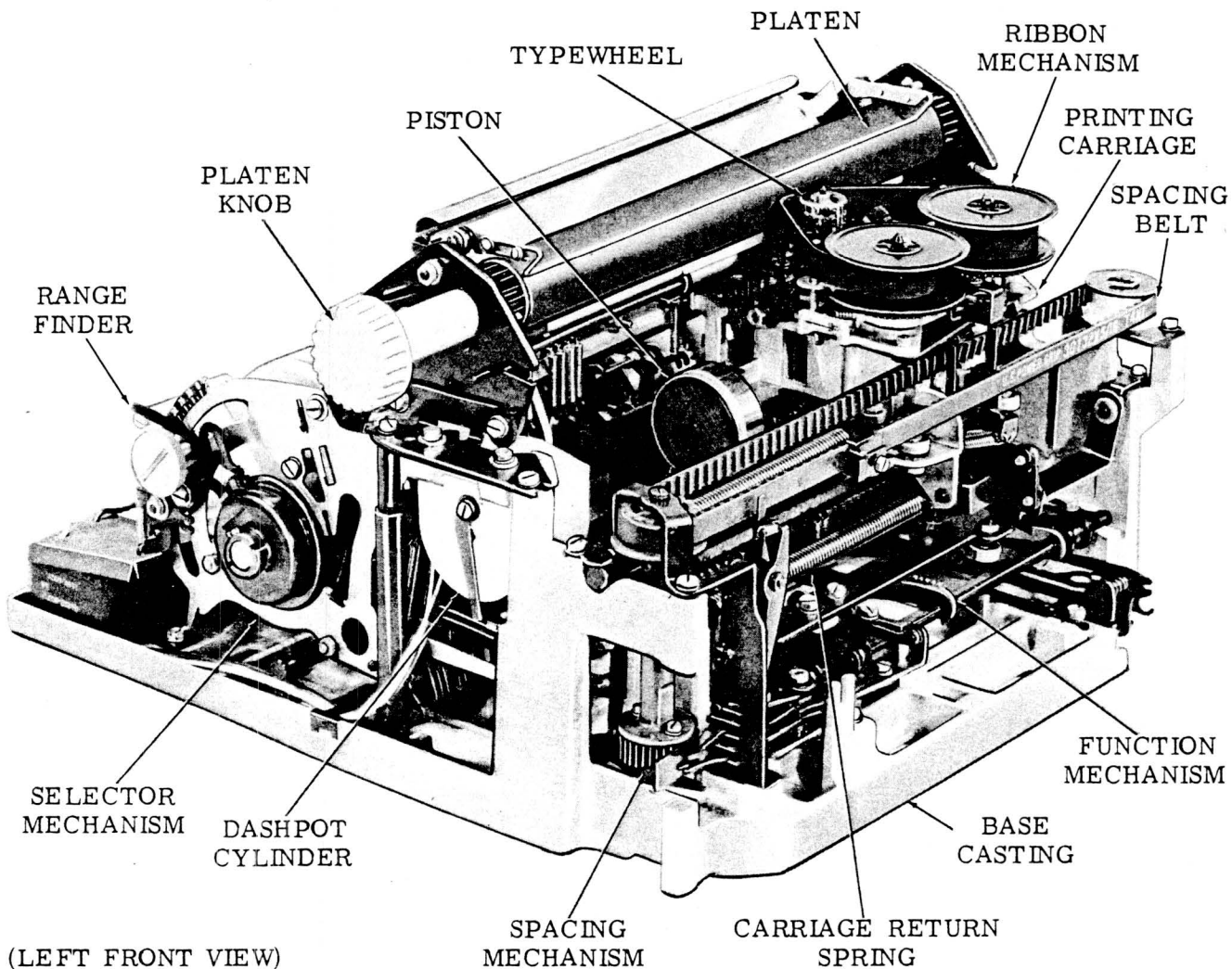

Figure 8 — Typing Unit (Friction Feed)

(d) A printing carriage which prints the messages on the paper. The characters are embossed on the cylindrical surface of a typewheel. The typewheel is positioned rotationally and vertically to select the proper characters, and a hammer drives it and an inked ribbon against the paper to effect printing. A ribbon mechanism feeds the ribbon and reverses its direction when one of its spools is depleted.

(e) A function mechanism which enables the typing unit to perform functions supplementary to printing. The standard functions are "space," "carriage return," "line feed,"

"blank," "bell," and (for the 32 typing unit) "letters" (lower case) and "figures" (upper case).

Note: In addition, sprocket feed typing units have the function "form-out."

(f) A paper feed mechanism which positions paper or forms vertically so that the characters are properly located in lines. A platen feeds the paper or forms. A knob permits manual feeding. The mechanism can be adjusted for single or double line feed.

(g) A spacing mechanism which positions the carriage so that the characters are properly located horizontally on the paper.

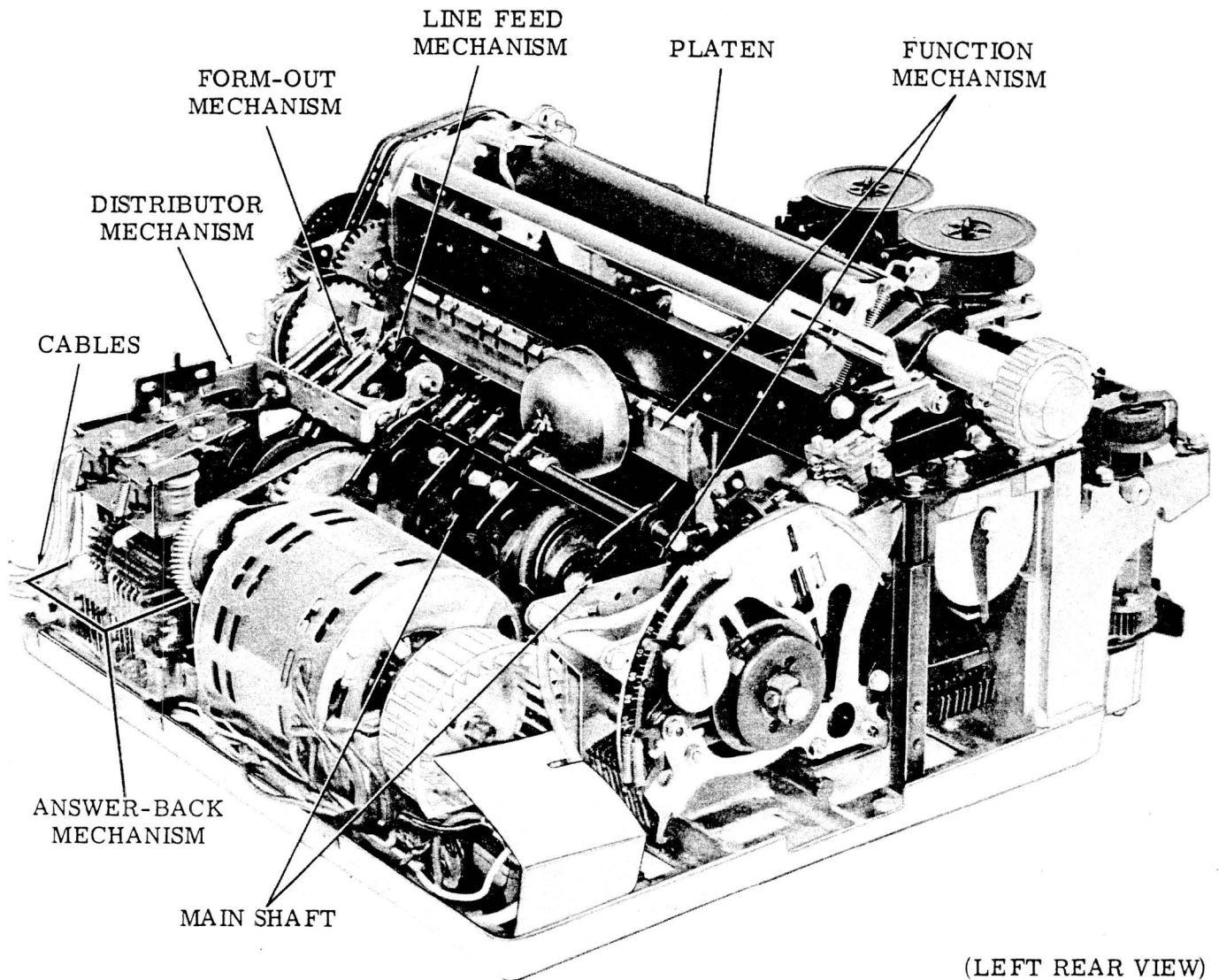

(LEFT REAR VIEW)

Figure 9 — Typing Unit (Sprocket Feed)

It moves the carriage, which rides on rollers, by a spacing belt. It returns the carriage to the left margin by a carriage return spring. The carriage is pneumatically stopped without shock by a piston and dash-pot cylinder arrangement.

(h) A disc and brush type distributor mechanism which converts the positions of the keyboard contacts (3.01 (c)) to start-stop signals for application to transmission facilities.

Note: An answer-back mechanism, which is an optional accessory, often is used in conjunction with the distributor. It will automatically transmit a sequence of characters for station identification. It may be coded to transmit any sequence of up to 20 characters and may be actuated locally or remotely.

(i) A base casting which provides mounting facilities for the mechanisms.

(j) Two cables with connectors which provide interconnection with the call control unit.

MOTOR AND DRIVE PARTS (Figure 10)

3.07 Mechanical motion for the 32 KSR and RO is ordinarily provided by a 2-pole, single-phase synchronous motor which operates from a 115 volt ac source and develops 25 millihorsepower at 3600 rpm. It consists basically of a housing, end bells, a wound stator, and a squirrel-cage rotor with shaft which rides on ball bearings. Cooling is provided by three fans — two within the end bells and one at the left end of the shaft. The motor is mounted by rubber vibration mounts which are clamped in a cradle formed in the typing unit's base casting. A start capacitor, a current-operated start relay, and a run capacitor are mounted on the base casting to the left of the motor. A pinion on the

right end of the shaft transfers the rotary motion generated by the motor to a set of drive parts which consist of a gear-pulley and motor belt.

3.08 The motor ordinarily used to provide motion for the 32 ASR and all 33 Teletypewriter Sets is similar to the one described above, except that it develops 33 millihorsepower, is equipped with sleeve bearings, and is not a capacitor-run motor.

CALL CONTROL UNIT (Figures 11 through 13)

3.09 The call control units couple the equipment to the transmission facilities and serve as an area of convergence for its circuitry. Two typical assemblies are shown in Figures 12 and 13.

3.10 A sheet metal plate secured to the sub-base provides mounting facilities.

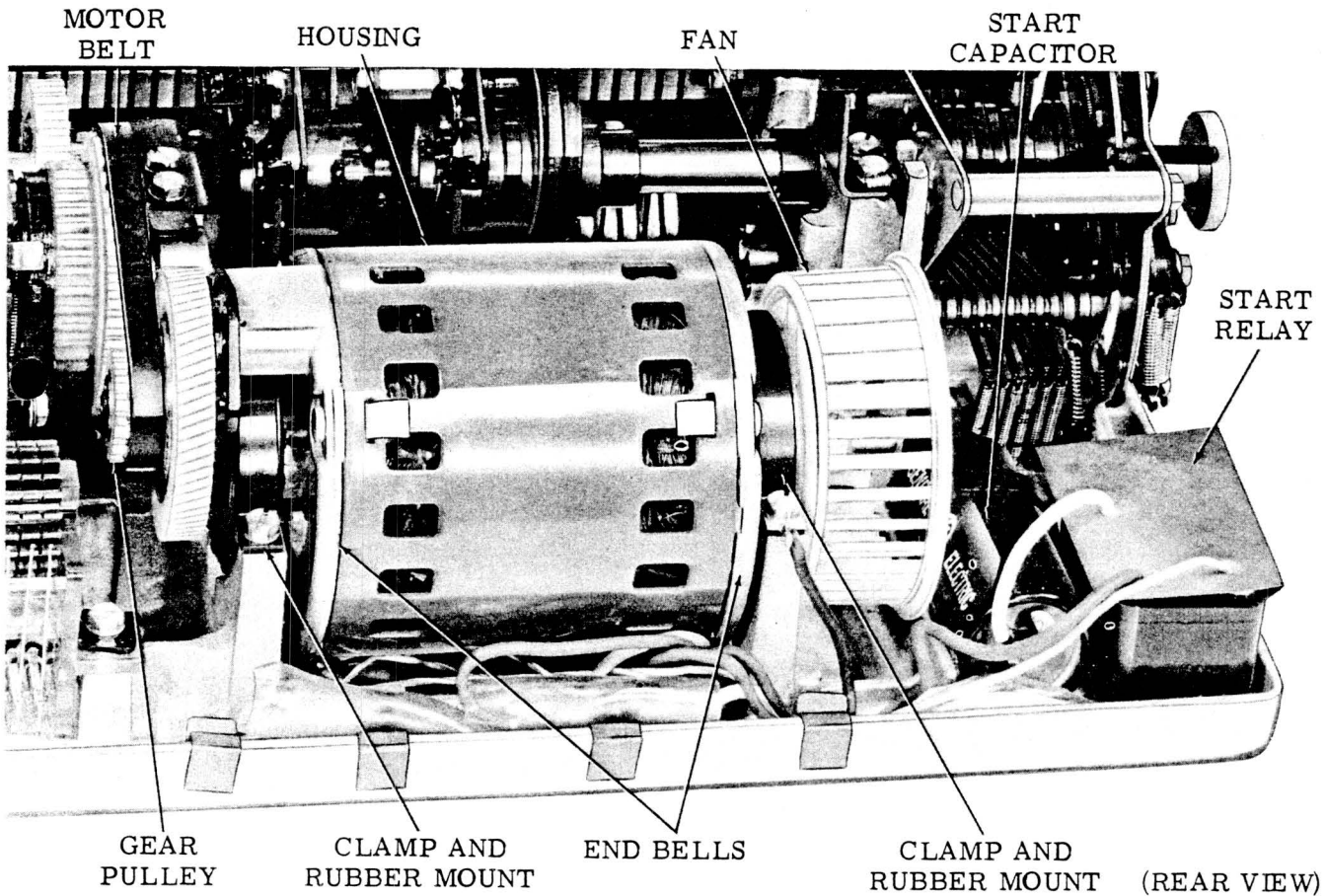

Figure 10 - Motor and Drive Parts

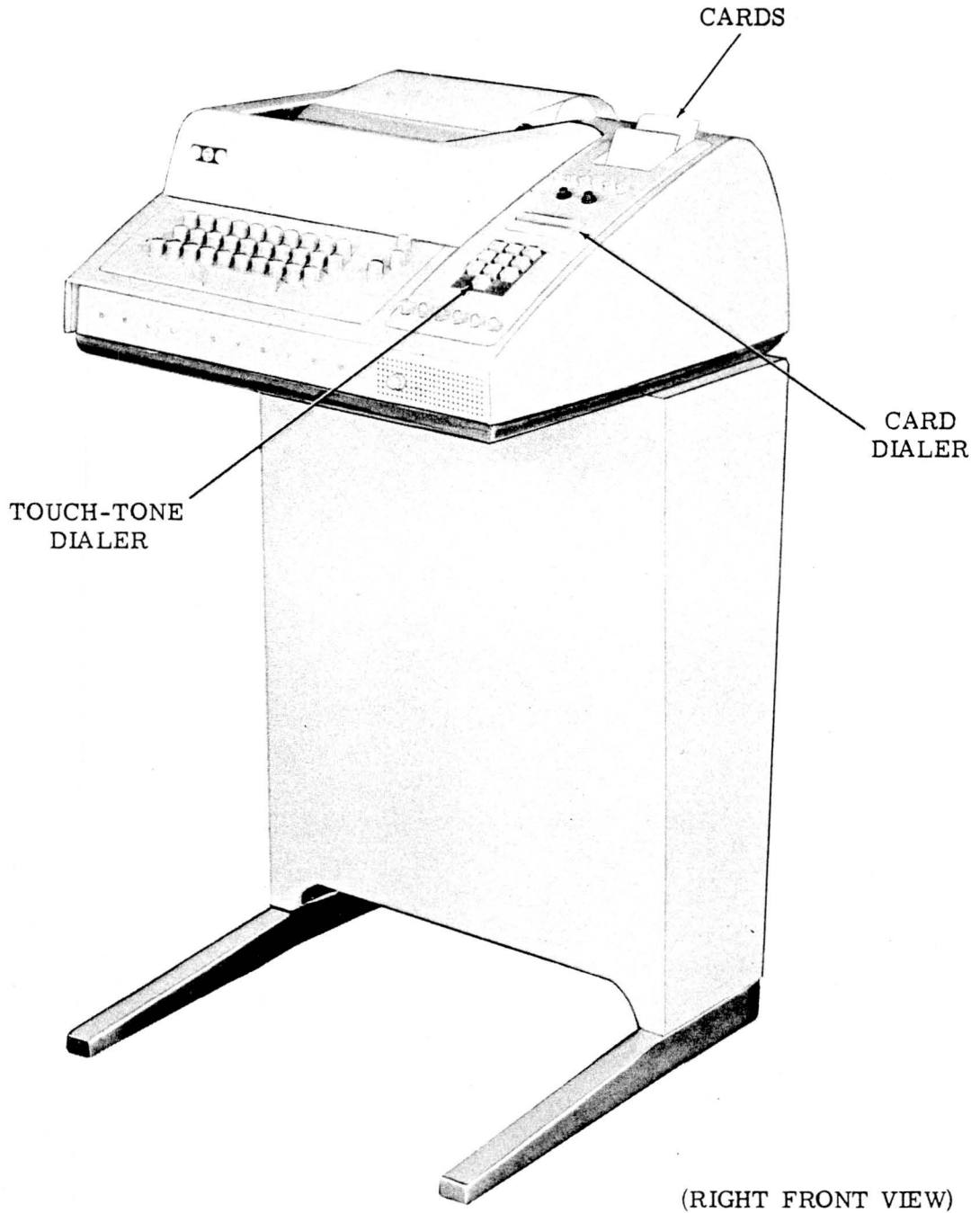

Figure 11— Keyboard Send-Receive (KSR) Teletypewriter Set with Card and Touch-Tone Dialers

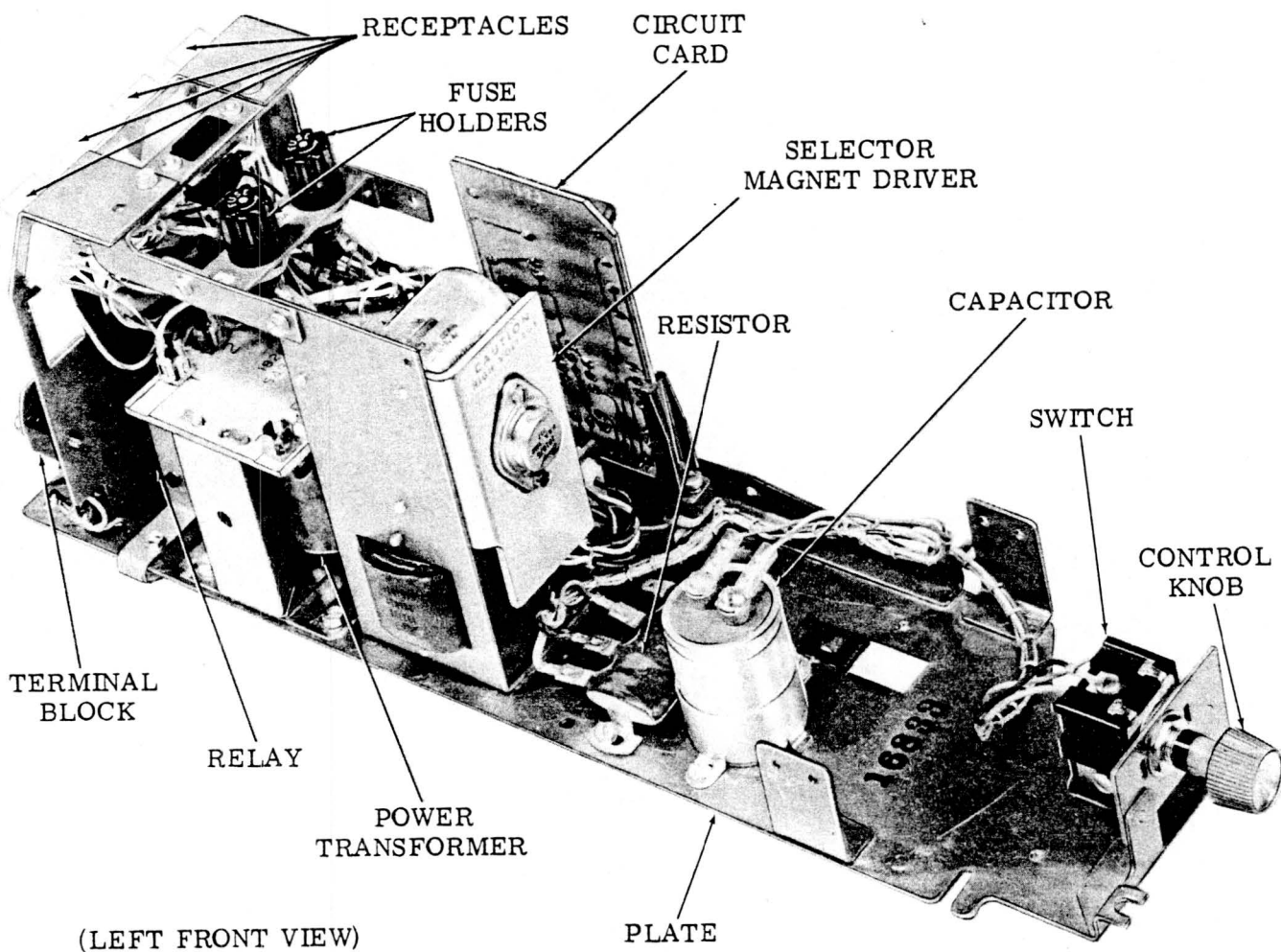

Figure 12 — Typical Call Control Unit

3.11 Call control units are available in variations that incorporate certain combinations of the following features:

- (a) A selector magnet driver which couples the equipment to the transmission facilities and repeats the line signals in a form that will efficiently operate the selector mechanism on the typing unit. It includes a transistorized circuit card, a transformer, a rectifier, and a capacitor filter.
- (b) Rotary, TOUCH-TONE and/or card dialers for making connections with other stations through dial switching facilities (Figures 3 and 11).
- (c) A ringer or buzzer which provides an audible indication of incoming calls.
- (d) A small speaker with volume control for monitoring dial tone, ringing, and busy signals on telephone networks. It is driven by a transistorized amplifier card.
- (e) Pushbuttons and lamps to aid in initiating, accepting, controlling, and terminating calls.
- (f) A motor control relay which will automatically turn the motor on and off.
- (g) Fuses which protect the circuitry of the equipment.
- (h) Automatic answering circuitry.
- (i) Interconnecting facilities, including receptacles, cables, and a terminal board.

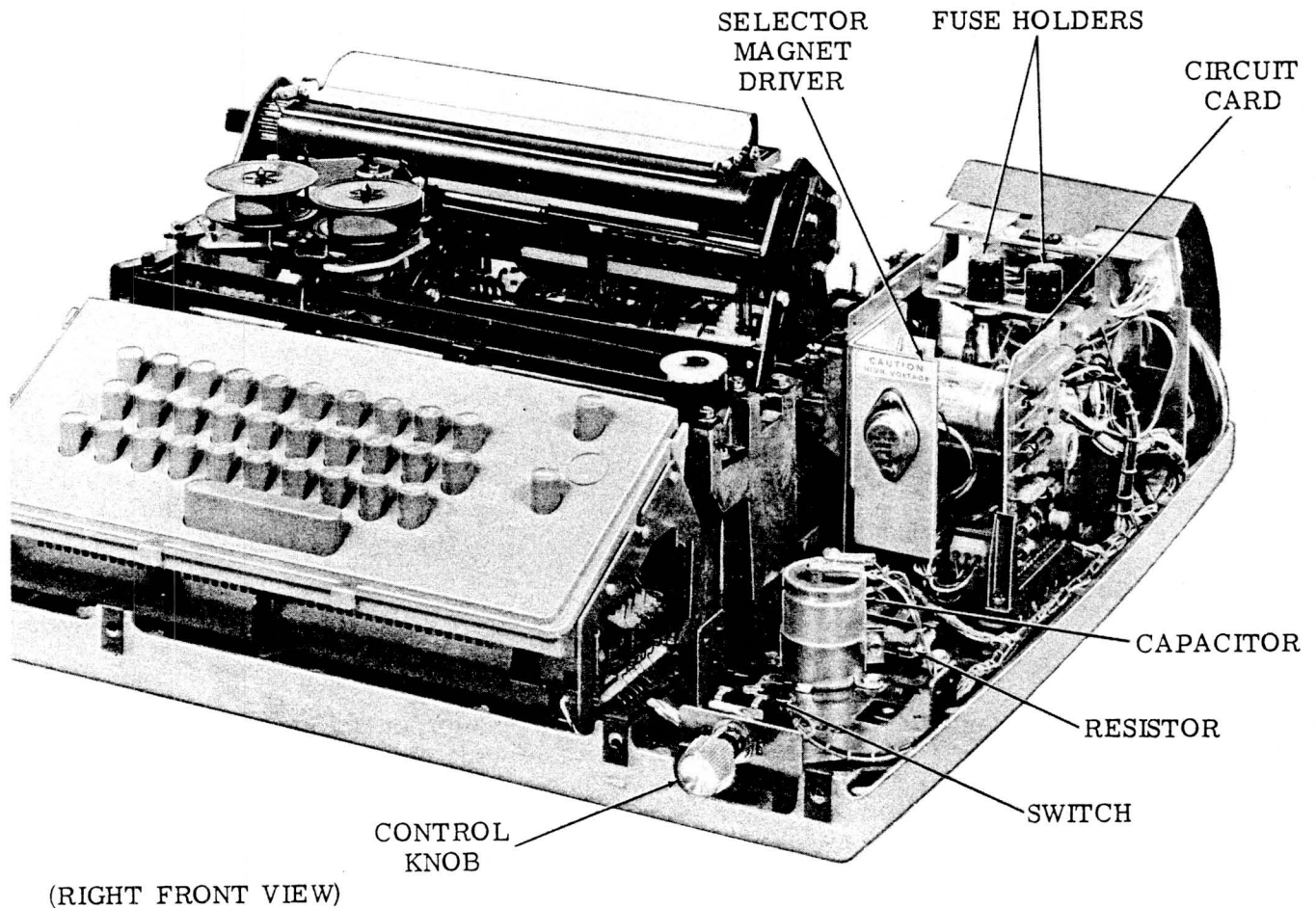

Figure 13 — Keyboard Send-Receive (KSR) Teletypewriter Set with Call Control Unit

#### COVER AND SUBBASE (Figures 2 and 5)

3.12 A plastic cover provides a decorative and protective enclosure of the typing unit, keyboard, and call control unit. A lid, which is spring detented in its open position, may be raised to gain access to the typing unit for changing ribbon or installing paper or forms. A window permits viewing the copy and provides a cutting edge for tearing the paper or forms. Depressions at the rear of the cover hold the paper roll spindle. Mounting slots are provided for a copy holder. A nameplate is mounted at the front.

3.13 The cover is mounted at its outer edges on a subbase casting which serves as a foundation for the keyboard, typing unit, and call control unit. Rubber vibration isolators support the typing unit.

#### TAPE READER (Figures 3 and 4)

3.14 The tape reader, in conjunction with the distributor mechanism on the typing unit, provides facilities for transmitting messages from perforated tape.

3.15 The complete tape reader package includes the following components:

- (a) A tape-sensing mechanism which converts code holes in the tape to corresponding positions in a set of contact springs. The holes are sensed by pins which operate the contact springs. The positions of the contact springs are converted to start-stop signals by the distributor mechanism.
- (b) A feed mechanism which advances the tape after a combination of code holes has been read. A feed pawl and ratchet

arrangement rotates a feed wheel whose pins engage feed holes in the tape. The tape feeds from rear to front and is held down on the sensing pins and feed wheel by a hinged tape lid which may be opened to facilitate tape threading.

(c) A feed magnet and armature arrangement which supplies motion for the sensing and feed mechanisms. It is pulsed by a contact on the distributor mechanism.

(d) A magnet-controlled clutch-trip mechanism which actuates the distributor mechanism. It is mounted above the distributor on the typing unit.

(e) A power pack, mounted in the enclosure of the stand, which provides current rectification for the feed magnet. It is protected by a metal housing.

(f) A cable which interconnects the tape reader with the power pack, the magnet pulsing contact, and the call control unit.

(g) Tape-out and tight-tape mechanisms which will stop the tape reader when it runs out of tape or when the tape becomes taut.

(h) A free-wheeling mechanism which disengages the feed wheel and tape-out mechanisms and permits the tape to be moved freely through the tape reader.

(i) A frame which is mounted on the typing unit's subbase and provides mounting facilities for the other mechanisms, excluding the power pack and clutch-trip mechanism.

(j) A base casting and plastic cover which provide a protective and decorative enclosure for the tape reader.

(k) The auxiliary ASR power supply is mounted in the enclosure of the stand (2.11 (a)). It is used in the off-line mode, to provide 115 volts on the tape reader, keyboard, answer-back, and distributor contacts only when a tape reader is used. When the tape reader is not used, a dummy plug with a jumper wire is inserted in position "R2" at the rear of the call control unit.

## TAPE PUNCH (Figures 3 and 4)

3.16 The tape punch, in conjunction with the selector and codebar mechanisms on the typing unit, provides facilities for perforating messages in paper tape. The messages are received as start-stop signals from the call control unit and are converted to mechanical motions that punch corresponding code holes in the tape.

3.17 The punch includes the following components:

(a) A drive mechanism which receives motion from the function rocker shaft on the typing unit and distributes it to other mechanisms.

(b) An intelligence-transfer mechanism which receives intelligence from the codebar mechanism on the typing unit.

(c) A tape-punching mechanism which, under the control of the intelligence-transfer mechanism, perforates feed and code holes in the tape by means of punch pins located in a holder.

(d) A tape feed and guide mechanism that advances the tape by means of rollers and a feed pawl and ratchet arrangement.

(e) A base casting which is attached to the typing unit base and provides mounting facilities for the various mechanisms.

(f) A supply reel which accommodates a roll of blank tape.

(g) A pan casting and 2-piece plastic cover which provides a protective and decorative enclosure for the tape punch.

(h) A metallic chad container which collects the paper (chad) punched out by punch pins.

3.18 The following four pushbuttons are provided:

(a) ON - Turns the tape punch on.

(b) OFF - Turns the tape punch off.

(c) REL (Release) - Releases the tape feed and guide mechanism so that tape can be easily removed from the tape punch.

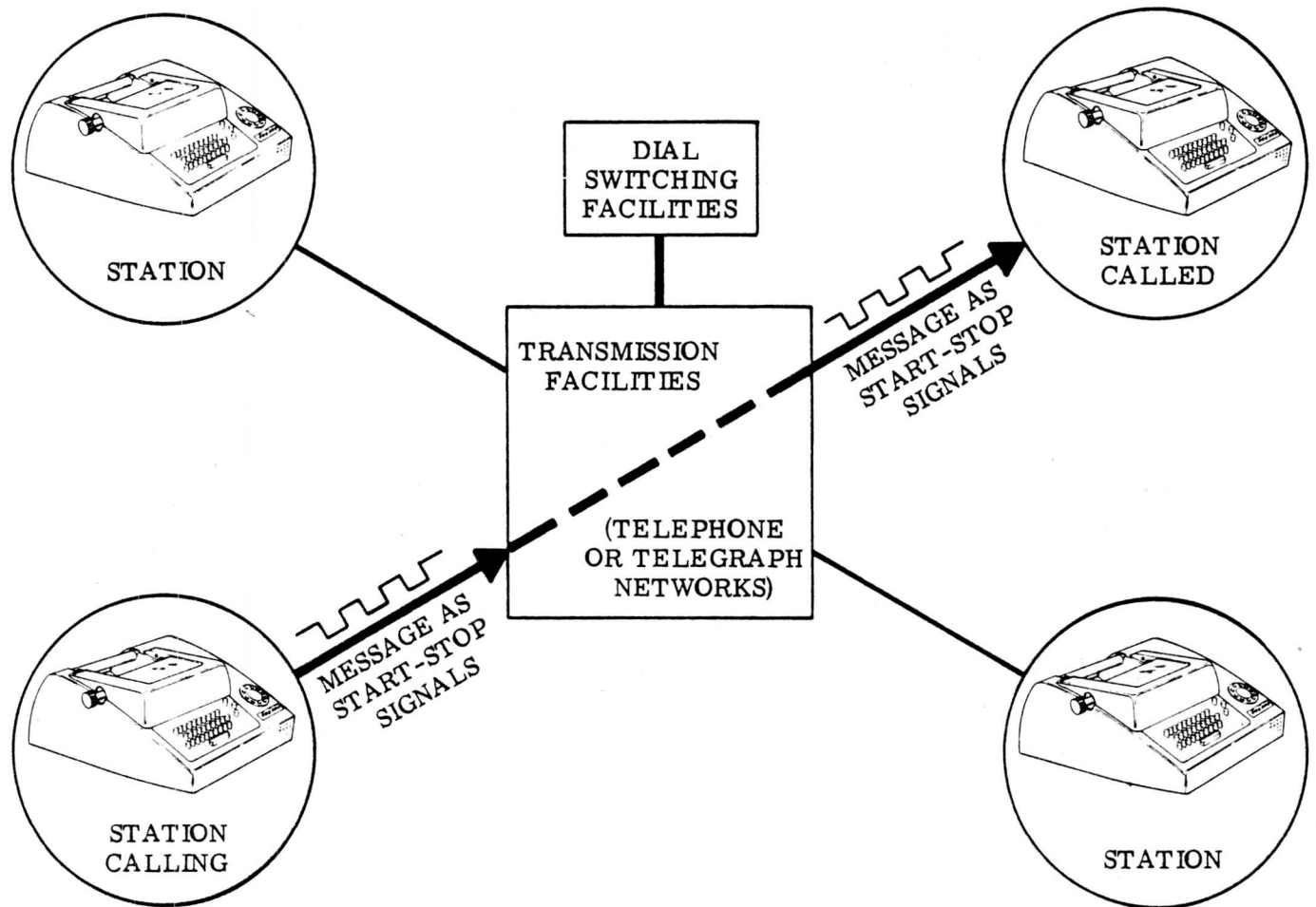

Figure 14 - Typical Applications

- (d) B. SP. (Backspace) - Backspaces tape one combination of code holes.

#### 4. TYPICAL APPLICATIONS (Figure 14)

4.01 The following is a brief description of how 32 or 33 Teletypewriter Sets, equipped with call control and answer-back features, may be used in a typical communication system. (See Figure 14.) When a call is to be made, an operator uses the controls on his Teletypewriter Set to gain access to the system's switching and transmission facilities, which may be dial telephone or telegraph networks. He then dials the number of the called station.

4.02 The switching center selects the proper station and signals an incoming call there by visual and/or audible indicators. Using the controls on his Teletypewriter Set, the operator at the called station completes the connection and

conditions the equipment so that communication can proceed in either direction, a fact that is indicated visually and/or audibly at the calling station.

Note: Variations of call control features provide unattended reception of calls.

4.03 Ordinarily the stations then identify themselves by the answer-back feature. The operator at the calling station can then type the message on his keyboard, or, if he has the ASR, can send it from perforated tape. In either case the Teletypewriter Set translates the message to dc sequential start-stop signals which it applies to the transmission facilities. The Teletypewriter Sets at both the sending and receiving stations receive the signals and translate them to mechanical motions which print the message on page copy or forms and/or, in the case of the ASR, perforate it in tape. If

telephone networks are used, the dc start-stop signals are converted to tone frequencies for transmission and reconverted to dc start-stop signals for reception.

4.04 Finally, the operator at either station can terminate the call and return the Teletypewriter Sets to their idle condition by his controls.

5. TECHNICAL DATA

5.01 Speeds . . . . . 60 wpm (364 opm),  
66 wpm (400 opm),  
100 wpm (600 opm)

Note: WPM = Words per minute, OPM = operations per minute.

5.02 Transmission Codes

32 Sets . . . 5-level start-stop signals with  
7.5-unit transmission pattern

33 Sets . . . 8-level start-stop signals with  
11-unit transmission pattern

5.03 Dimensions and Weight (Approximate)

(a) KSR

Width . . . . . 18-5/8 inches  
Depth . . . . . 18-1/2 inches  
Height . . . . . 8-3/8 inches  
Weight . . . . . 40 pounds

(b) RO

Width, depth and height same as KSR  
in 5.03(a) above

Weight . . . . . 39 pounds

(c) ASR

Width . . . . . 22 inches  
Depth . . . . . 18-1/2 inches  
Height . . . . . 8-3/8 inches  
Weight . . . . . 44 pounds

(d) Stand

Width . . . . . 17-3/4 inches  
Height . . . . . 24-1/2 inches  
Depth at Top of  
Enclosure . . . . . 8 inches  
Depth of Bottom of  
Enclosure . . . . . 6-1/2 inches  
Length of Feet . . . . . 17-3/4 inches  
Weight . . . . . 12 pounds

5.04 Electrical

Power Requirements . . 115-volts ac  $\pm 10\%$   
60 cps  $\pm 0.45$  cycle, single phase  
Signal Line Current . . . . . 0.020 or 0.060  
ampere

Nominal Input to  
Selector. . . 0.500 ampere at 20-volts dc

Operating Margins-All signal contacts and  
Distributor:

Long Telegraph Loops . . 0.015 to 0.070  
ampere at 48-to 240-volts dc  
inductive  
Short Telegraph Loops . . 0.058 to 0.072  
ampere at 16-to 22-volts dc resistive

5.05 Printing and Paper or Form Handling

Feed

Friction or Sprocket: six lines per inch,  
adjustable for single or double line  
feed.

Paper or Form

Friction Feed: 8-1/2 inches wide, max  
5-inch diameter roll.  
Sprocket Feed: 8-1/2 inches wide; 7-,  
8-1/2-, 9-, 10-, 11-, and 12- inch  
form lengths or multiples of 1/3 or  
1/2 thereof.

Characters and Line

Friction Feed: 10 characters per inch,  
max 74 character line  
Sprocket Feed: 10 characters per inch,  
max 72 character line

Legible Copies:

Friction Feed: original and one copy  
Sprocket Feed: original and two copies

5.06 Motor (TP181870-ordinarily used on 32  
ASR and all 33 Sets)

Type . . . . . Synchronous, capacitor start  
Input . . . . . 115-volts ac  $\pm 10\%$ , 60 cps  
 $\pm 0.45$  cycle, single phase  
Input Current . . . . . 2 amperes  
Output . . . . . 33 millihorsepower  
Speed . . . . . 3600 rpm  
Temperature Rating . . . . . 50°C continuous  
Power Factor . . . . . 0.40

5.07 Motor (TP181861-ordinarily used on 32 R/O and KSR)

Same as 5.06 above except as follows:

- Type . . . Synchronous, capacitor start and run
- Input Current . . . . . 0.85 ampere
- Output . . . . . .25 millihorsepower
- Power Factor . . . . . .0.70

5.08 Tape Reader

(a) Dimensions and Weight (Approximate)

Feeding and Sensing Portion

- Width . . . . . 3-1/2 inches
- Depth . . . . . .4 inches
- Height . . . . . 3-1/2 inches
- Weight . . . . . 2 pounds

Power Pack

- Width . . . . . 6-1/4 inches
- Depth . . . . . 2-1/2 inches
- Height . . . . . 2-3/4 inches
- Weight . . . . . 1 pound

(b) Power Pack

High Voltage:

- Input . . . . . 115-volts ac (see "Power Requirements" in par. 5.04)

- Output . . . . . Min. 137-volts dc @ 0.160 ampere
- Low Voltage (Rectifier for Relay\*):
- Input . . . . . 48-volts ac
- Output . . . . . 32 ± 8-volts dc
- Heat Dissipation with Tape Reader Operating . . . . . 17 watts

\*Applicable to tape readers equipped with automatic reader control.

CAUTION: HIGH VOLTAGE PERSISTS 10 SECONDS AFTER POWER REMOVED.

(c) Feed Magnet

- Power Dissipation . . . . . 2-1/4 watts
- Nominal Attract Time . . . . . 8-11 milliseconds at 0.220 ampere
- Nominal Release Time . . . . . 7-10 milliseconds

5.09 Tape Punch

(a) Dimensions and Weight (Approximate)

- Width . . . . . 3-1/2 inches
- Height . . . . . 7-1/2 inches
- Depth . . . . . 13-1/4 inches
- Weight . . . . . 1-1/2 pounds

(b) Tape Specifications

- Levels . . . . . 5-or 8-level
- Width - (5-level) . . . . . 11/16 inch
- Width - (8-level) . . . . . 1 inch
- Code Combinations per inch . . . . . 10
- Feed Hole Diameter . . . . . 0.0465 inch

32 AND 33 TELETYPEWRITER SET

INSTALLATION

CONTENTS	PAGE	1. GENERAL
1. GENERAL . . . . .	1	1.01 This section provides instructions for unpacking, installing, connecting, and preparing the 32 and 33 Teletypewriter Set for use. A 115-volt power source and signal-line current and leads must be furnished by the customer. See the appropriate description section for detailed power and signal-line requirements.
UNPACKING . . . . .	1	
PREPARATION FOR INSTALLATION . . . . .	2	
2. INSTALLATION . . . . .	6	1.02 This section is reissued as a general revision. Because of this, marginal arrows ordinarily used to indicate changes have been omitted.
MOUNTING TYPING UNIT ON STAND . . . . .	6	
CODING ANSWER-BACK DRUM . . . . .	6	
ADJUSTMENTS . . . . .	8	1.03 References to "left," "right," "front," or "rear," etc, consider the Teletypewriter Set to be viewed from a position where the typing unit carriage faces up and the typing unit selector mechanism is located to the viewer's left.
PLACEMENT . . . . .	8	
ELECTRICAL CONNECTION . . . . .	9	
3. FINAL ASSEMBLY . . . . .	9	UNPACKING
GENERAL . . . . .	9	1.04 The Teletypewriter Set is packed in one carton. Observe all caution and instruction labels on the carton before breaking the seals. Remove the upper filler pads. Carefully take out the typing unit to avoid marring or otherwise damaging the plastic cover. Remove the remaining carton fillers and take out the stand (if used).
RIBBON INSTALLATION . . . . .	9	
PAPER OR FORM INSTALLATION . . . . .	11	
A. Friction Feed . . . . .	11	
B. Sprocket Feed . . . . .	11	
4. OPTIONAL FEATURES . . . . .	12	1.05 The typing unit and subbase are mounted on a wooden shipping pallet by seven screws. Four of the screws are no. 14Z self-tapping screws that secure the subbase to the pallet. The remaining three are standard machine screws that pass through aluminum bushings into tapped holes in the typing unit's base casting. Since the typing unit floats on rubber mounts, it is secured with separate screws. Tilt the mounted typing unit and take out the screw in the countersunk hole first. Loosen the
A. Copy Holder . . . . .	12	
B. Hum Squelch . . . . .	13	
C. Busy Circuit . . . . .	14	
D. Hand Receiver . . . . .	14	
5. TAPE READER . . . . .	15	
6. POWER PACK ASSEMBLY . . . . .	15	
7. TAPE PUNCH . . . . .	16	

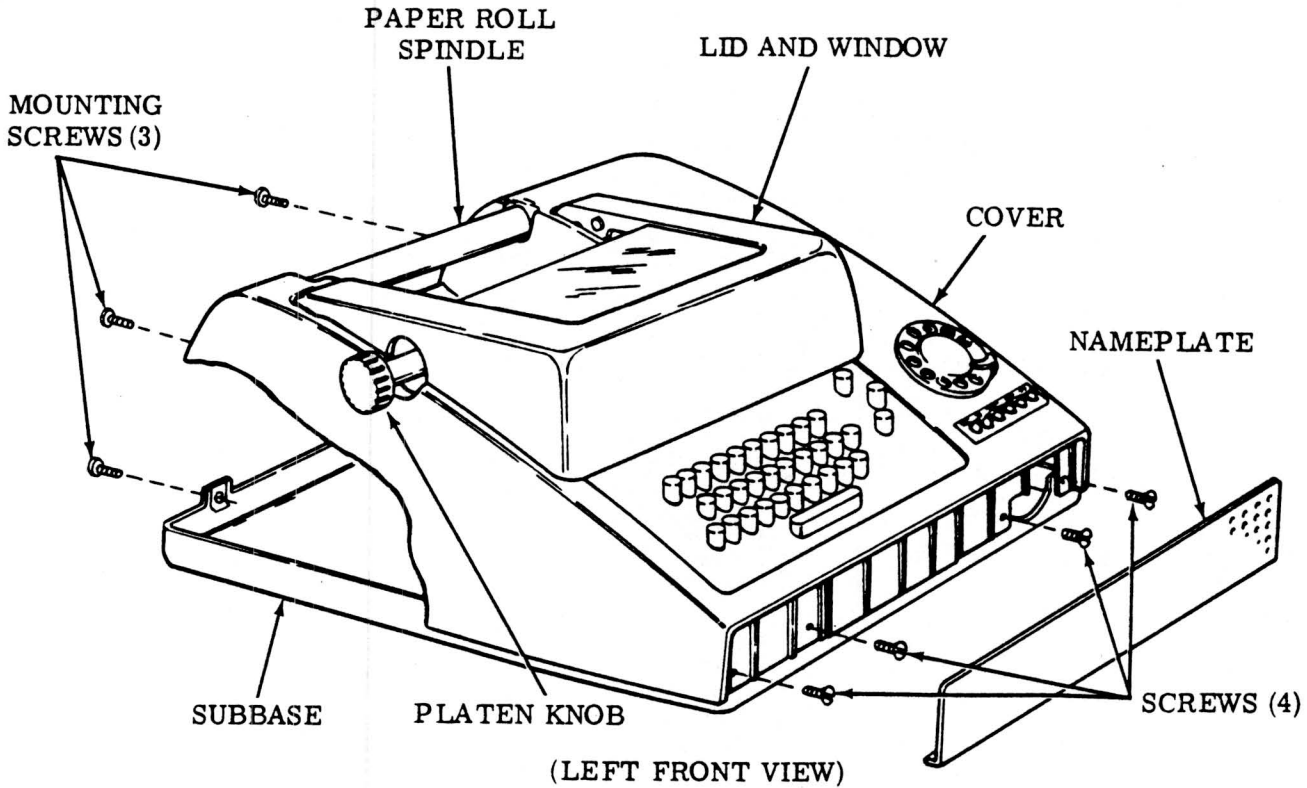

Figure 1 - Cover Mounting

remaining six screws slightly. Return the typing unit to its upright position. Slide it to the edge of the bench and remove the six screws by hand. The typing unit can now be lifted from the pallet. Discard the seven mounting screws and the three aluminum bushings.

**CAUTION:** DO NOT TILT THE TYPING UNIT AFTER IT HAS BEEN REMOVED FROM THE PALLET. THE TYPING UNIT FLOATS ON RUBBER ISOLATORS AND MAY PULL LOOSE IF IT IS TILTED.

**PREPARATION FOR INSTALLATION**

- 1.06 Remove the tape from across the top of the cover and take out the cables, platen knob, and paper spindle from the paper recess. Unwrap the parts.
- 1.07 Remove the bezel, if used, from the call control unit by removing two mounting screws. Remove the volume control knob, if used, or the power switch rotary knob, if used, by pulling frontward. Remove the nameplate by pulling it down and out (Figure 1). This will

expose four cover mounting screws. Remove these screws and three mounting screws from the rear of the cover. Gently lift the cover from the subbase.

**Note:** On Automatic Send-Receive (ASR) Teletypewriter Sets, remove the screw from the left rear corner of the tape reader cover before gently lifting the ASR cover from the subbase.

- 1.08 Remove the twist-tie on the left side that holds the carriage, the tissue paper below it that retains spacing pawls, and the two yellow clips from under the hooks of the function levers.
- 1.09 If a stand is used, place it in an uncrowded area. Remove two mounting screws and take off the rear panel. Remove the copy holder, if used, from inside the stand. Take the hardware out of the bag tied to the stand.
- 1.10 Using the screws supplied with the data set, if used, fasten the set to the relay rack.

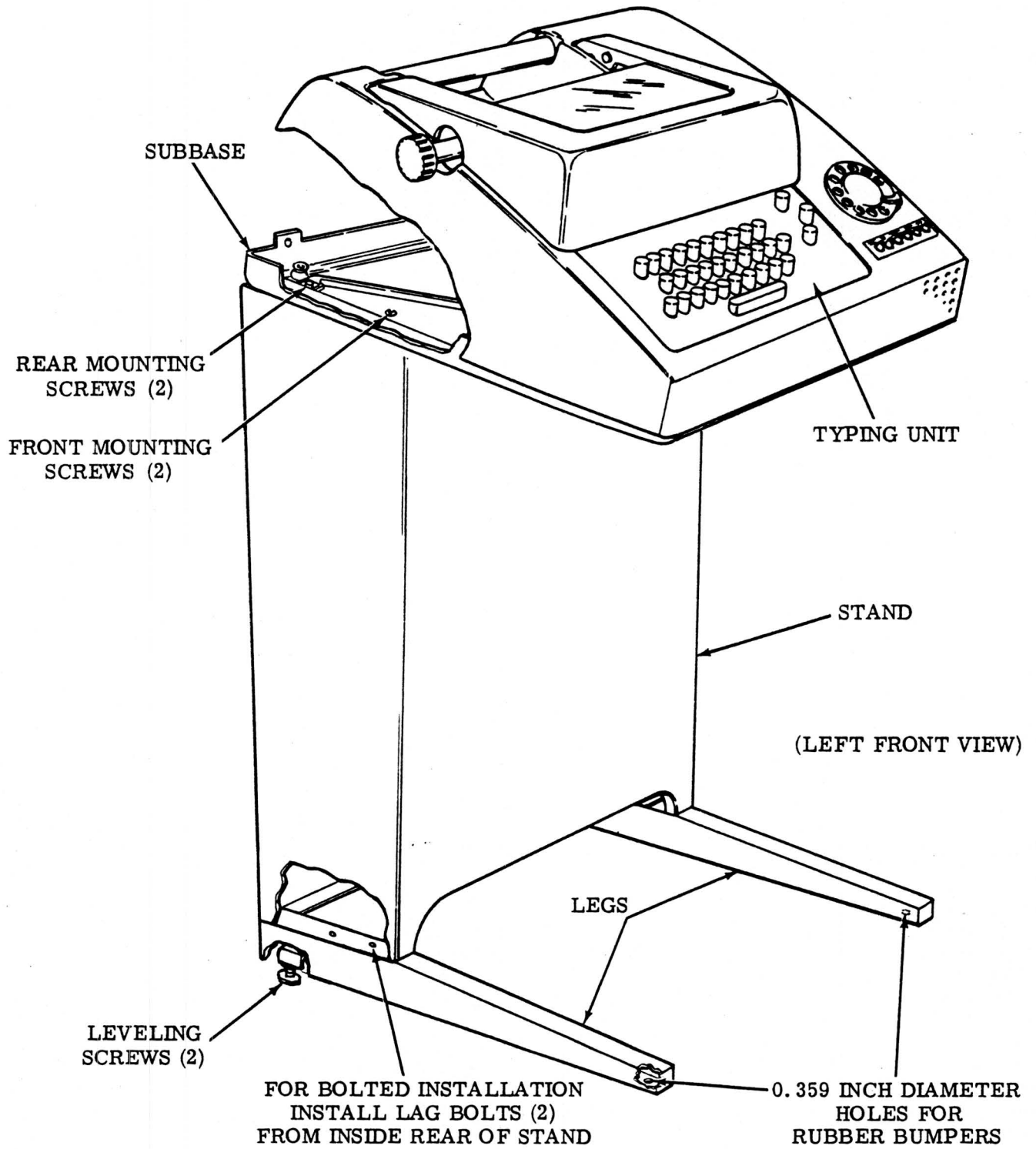

Figure 2 - Stand Leveling and Anchoring and Assembly of Subbase with Typing Unit to Stand

ANSWER-BACK DRUM

LETTERS TWX & TELEX	FIGURES TWX	FIGURES TELEX	CODE LEVELS					
			5	4	3	2	1	
A	-	-	■	■	■	■	■	■
B	5/8	?	■	■	■	■	■	■
C	WRU	:	■	■	■	■	■	■
D	\$	+	■	■	■	■	■	■
E	3	3	■	■	■	■	■	■
F	1/4	\$	■	■	■	■	■	■
G	&	&	■	■	■	■	■	■
H		#	■	■	■	■	■	■
I	8	8	■	■	■	■	■	■
J	,	BELL	■	■	■	■	■	■
K	1/2	(	■	■	■	■	■	■
L	3/4	)	■	■	■	■	■	■
M	.	.	■	■	■	■	■	■
N	7/8	,	■	■	■	■	■	■
O	9	9	■	■	■	■	■	■
P	0	0	■	■	■	■	■	■
Q	1	1	■	■	■	■	■	■
R	4	4	■	■	■	■	■	■
S	BELL	'	■	■	■	■	■	■
T	5	5	■	■	■	■	■	■
U	7	7	■	■	■	■	■	■
V	3/8	;	■	■	■	■	■	■
W	2	2	■	■	■	■	■	■
X	/	/	■	■	■	■	■	■
Y	6	6	■	■	■	■	■	■
Z	"	"	■	■	■	■	■	■
CARRIAGE RETURN			■	■	■	■	■	■
LINE FEED			■	■	■	■	■	■
LETTERS SHIFT			■	■	■	■	■	■
FIGURES SHIFT			■	■	■	■	■	■
SPACE			■	■	■	■	■	■
BLANK			■	■	■	■	■	■
1 CYCLE OPER - ROW 6			■	■	■	■	■	■
1 CYCLE OPER - ROW ST			■	■	■	■	■	■
2 CYCLE OPER - ROWS 6&17			■	■	■	■	■	■
2 CYCLE OPER - ROWS ST&11			■	■	■	■	■	■
3 CYCLE OPER - ROWS 6,13, & 20			■	■	■	■	■	■
3 CYCLE OPER - ROWS ST, 7, & 14			■	■	■	■	■	■

CHARACTER SUPPRESSION  
STOP CAM  
FEED RATCHET

NOT USED  
LEVELS

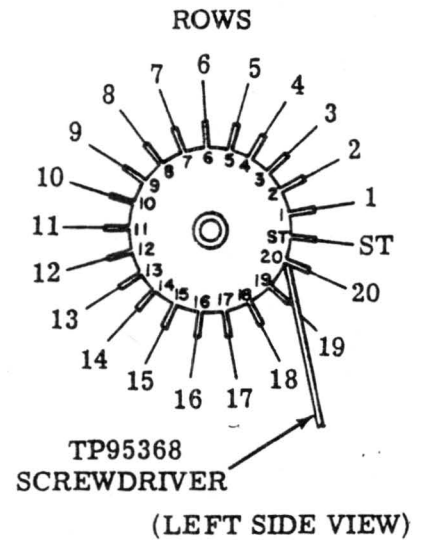
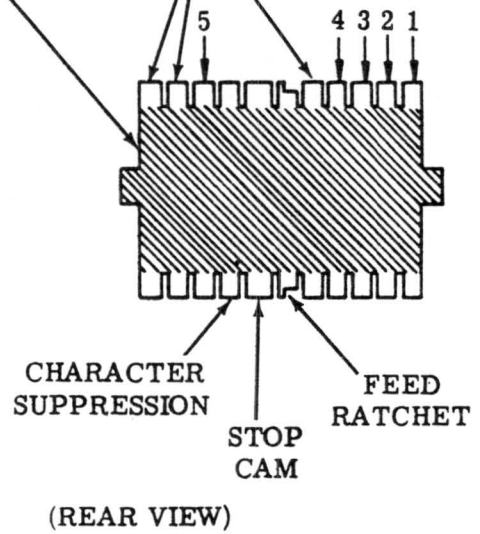

■ LEAVE TINE  
□ REMOVE TINE

Figure 3 - Coding of Answer-Back Drum — 32 Teletypewriter Set

ANSWER-BACK DRUM

LEVELS

33	CODE LEVELS								33	CODE LEVELS							
	8	7	6	5	4	3	2	1		8	7	6	5	4	3	2	1
NULL	■	■	■	■	■	■	■	■	2	□	□	□	□	□	□	□	
SOM	□	■	■	■	■	■	■	■	3	□	□	□	□	□	□	□	
EOA	□	■	■	■	■	■	■	■	4	□	□	□	□	□	□	□	
EOM	□	■	■	■	■	■	■	■	5	□	□	□	□	□	□	□	
EOT	□	■	■	■	■	■	■	■	6	□	□	□	□	□	□	□	
WRU	□	■	■	■	■	■	■	■	7	□	□	□	□	□	□	□	
RU	□	■	■	■	■	■	■	■	8	□	□	□	□	□	□	□	
BELL	□	■	■	■	■	■	■	■	9	□	□	□	□	□	□	□	
FE <sub>0</sub>	□	■	■	■	■	■	■	■	:	□	□	□	□	□	□	□	
HT	□	■	■	■	■	■	■	■	;	□	□	□	□	□	□	□	
LF	□	■	■	■	■	■	■	■	<	□	□	□	□	□	□	□	
VT	□	■	■	■	■	■	■	■	=	□	□	□	□	□	□	□	
FF	□	■	■	■	■	■	■	■	>	□	□	□	□	□	□	□	
CR	□	■	■	■	■	■	■	■	?	□	□	□	□	□	□	□	
SO	□	■	■	■	■	■	■	■	@	□	□	□	□	□	□	□	
SI	□	■	■	■	■	■	■	■	A	□	□	□	□	□	□	□	
DC <sub>0</sub>	□	■	■	■	■	■	■	■	B	□	□	□	□	□	□	□	
XON	□	■	■	■	■	■	■	■	C	□	□	□	□	□	□	□	
XION	□	■	■	■	■	■	■	■	D	□	□	□	□	□	□	□	
XOFF	□	■	■	■	■	■	■	■	E	□	□	□	□	□	□	□	
RIOFF	□	■	■	■	■	■	■	■	F	□	□	□	□	□	□	□	
ERROR	□	■	■	■	■	■	■	■	G	□	□	□	□	□	□	□	
SYNCH	□	■	■	■	■	■	■	■	H	□	□	□	□	□	□	□	
EOB	□	■	■	■	■	■	■	■	I	□	□	□	□	□	□	□	
S <sub>0</sub>	□	■	■	■	■	■	■	■	J	□	□	□	□	□	□	□	
S <sub>1</sub>	□	■	■	■	■	■	■	■	K	□	□	□	□	□	□	□	
S <sub>2</sub>	□	■	■	■	■	■	■	■	L	□	□	□	□	□	□	□	
S <sub>3</sub>	□	■	■	■	■	■	■	■	M	□	□	□	□	□	□	□	
S <sub>4</sub>	□	■	■	■	■	■	■	■	N	□	□	□	□	□	□	□	
S <sub>5</sub>	□	■	■	■	■	■	■	■	O	□	□	□	□	□	□	□	
S <sub>6</sub>	□	■	■	■	■	■	■	■	P	□	□	□	□	□	□	□	
S <sub>7</sub>	□	■	■	■	■	■	■	■	Q	□	□	□	□	□	□	□	
SPACE	□	□	□	□	□	□	□	□	R	□	□	□	□	□	□	□	
I	□	□	□	□	□	□	□	□	S	□	□	□	□	□	□	□	
II	□	□	□	□	□	□	□	□	T	□	□	□	□	□	□	□	
#	□	□	□	□	□	□	□	□	U	□	□	□	□	□	□	□	
\$	□	□	□	□	□	□	□	□	V	□	□	□	□	□	□	□	
%	□	□	□	□	□	□	□	□	W	□	□	□	□	□	□	□	
&	□	□	□	□	□	□	□	□	X	□	□	□	□	□	□	□	
'	□	□	□	□	□	□	□	□	Y	□	□	□	□	□	□	□	
(	□	□	□	□	□	□	□	□	Z	□	□	□	□	□	□	□	
)	□	□	□	□	□	□	□	□	c	□	□	□	□	□	□	□	
*	□	□	□	□	□	□	□	□	\	□	□	□	□	□	□	□	
+	□	□	□	□	□	□	□	□	]	□	□	□	□	□	□	□	
,	□	□	□	□	□	□	□	□	↑	□	□	□	□	□	□	□	
-	□	□	□	□	□	□	□	□	←	□	□	□	□	□	□	□	
.	□	□	□	□	□	□	□	□	ACK	□	□	□	□	□	□	□	
/	□	□	□	□	□	□	□	□	ALT MODE	□	□	□	□	□	□	□	
0	□	□	□	□	□	□	□	□	ESC	□	□	□	□	□	□	□	
I	□	□	□	□	□	□	□	□	RUB OUT	□	□	□	□	□	□	□	
1 CYCLE OPER ROW 6										■	■	■	■	■	■	■	
1 CYCLE OPER ROW ST										■	■	■	■	■	■	■	
2 CYCLE OPER ROWS 6 & 17										■	■	■	■	■	■	■	
2 CYCLE OPER ROWS ST & 11										■	■	■	■	■	■	■	
3 CYCLE OPER ROWS 6, 13, 20										■	■	■	■	■	■	■	
3 CYCLE OPER ROWS ST, 7, 14										■	■	■	■	■	■	■	

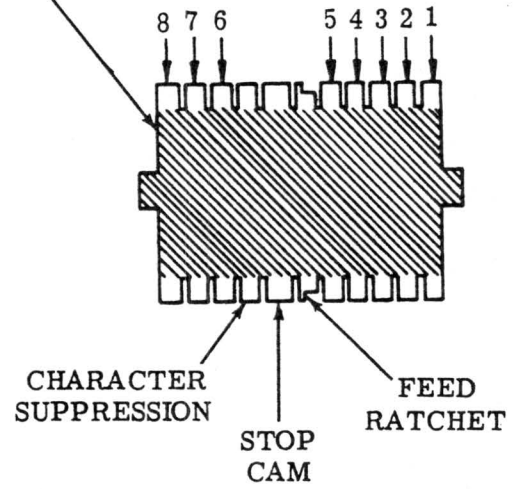

(REAR VIEW)

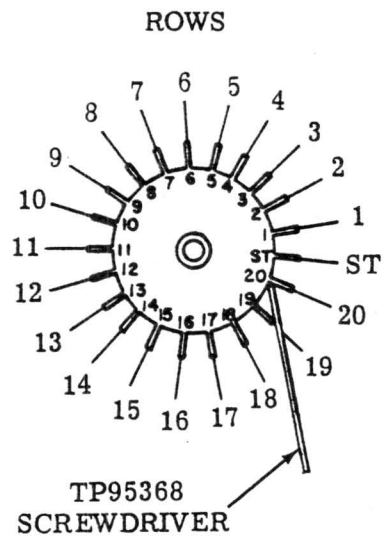

(LEFT SIDE VIEW)

- LEAVE TINE
- REMOVE TINE

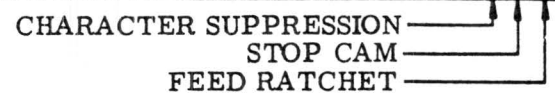

Figure 4 - Coding of Answer-Back Drum — 33 Teletypewriter Set

## 2. INSTALLATION

### MOUNTING TYPING UNIT ON STAND

2.01 If the Teletypewriter Set is to be bolted to the floor, remove the front screw in each leg of the stand (Figure 2).

2.02 The subbase with the typing unit is mounted on the stand (Figure 2) by four no. 14Z screws with flat washers. Some subbases may use two no. 14Z screws and two no. 10-32 hex head screws. The two no. 14Z screws are used in two rear mounting holes, and the two no. 10-32 screws with flat washers and lock-washers are used in the two front tapped bosses of the subbase.

2.03 Place the subbase with the typing unit on top of the stand so that its back edge and sides line up with the back edge and sides of the stand. Support the subbase with typing unit at all times until one, or, preferably, both screws are inserted and tightened. Insert two no. 14Z screws carefully to avoid dislodging the speed nuts located in the subbase. There are three pairs of holes in the top of the stand. Use the most rearward and most frontward pairs. Secure the mounting screws.

### CODING THE ANSWER-BACK DRUM

2.04 Figures 3 and 4 illustrate the coding of the answer-back drum.

2.05 Remove the answer-back drum as follows:

- (a) Disengage the distributor clutch.
- (b) Stand at the rear of the Teletypewriter Set and rotate the answer-back drum in the frontward direction while pulling toward the rear against the tension of the contact springs and the detent lever until the drum shaft is just clear of the right and left slots in the contact block.
- (c) Lift the feed pawl and remove the answer-back drum. Do not overextend the feed pawl spring.

2.06 The answer-back drum, prior to coding, is identical in either 5- or 8-level operation. As can be seen in Figure 3, three levels are not used when coding the answer-back drum for 5-level operation. The tines in these three levels may be left intact, since

no contact wire springs sense these positions. When coding the answer-back drum for 8-level operation, all levels on the answer-back drum are used (see Figure 4).

2.07 Code the answer-back drum in a counter-clockwise direction, as viewed from the numbered end, beginning with row no. 1.

Note: The ST row is actually the first row sensed, and the beginning of a cycle of answer-back operation, but it is coded at the factory for character suppression and requires no coding by customers.

2.08 A row is coded for a particular character by breaking and removing the tine(s) as designated in Figures 3 or 4. Either of the two following methods may be used for breaking off tines:

(a) Method 1: Use a TP95368 screwdriver to remove each tine. Place the end of the screwdriver blade at the base of the tine to be removed. While applying pressure against the base of the adjacent tine, press the side of the blade against the top of the tine to be removed until it breaks. If both tines adjacent to the tine to be removed have been broken off, apply the end of the screwdriver to the stub of either one in breaking off the unwanted tine. This method of removing a tine is indicated in the illustration showing the tine rows in Figures 3 and 4. In the illustration, pressure is being applied to the base of a row no. 20 tine and against the top of an adjacent tine in row no. 19 to break it off.

(b) Method 2: Use a TP161686 tine tool or a pair of TP108285 long-nosed pliers to remove each unwanted tine. Place the unwanted tine into slot of the tine tool, or grasp the unwanted tine firmly with the long-nosed pliers, and then, with the tool or the pliers held stationary, rotate the answer-back drum back and forth until the unwanted tine breaks off near its base. Use care not to damage adjacent tines.

2.09 The length of an answer-back sequence can be varied either by removing the stop cam level tines and/or the character suppression level tines.

(a) A 1-, 2-, or 3-cycle operation can be obtained by removing the appropriate

tine(s) from the stop cam level, as indicated in Figures 3 and 4.

Note: Whenever a stop cam tine is removed, the character suppression tine in the same row must also be removed.

(b) For short sequences, consider coding the answer-back drum for either 2- or 3-cycle operation. When the answer-back drum is coded for multiple-cycle operation, each segment must have the same message coded into it. For longer sequences, code the answer-back drum for 1-cycle operation.

(c) By removing the character suppression tine from rows which are surplus after coding a message into the answer-back drum, the length of an answer-back sequence can be shortened. The removal of the character suppression tine from any row prevents the transmission on the signal line of character code combinations from the answer-back mechanism. Do not, however, remove the character suppression tine from the last row of each segment of the answer-back drum—row no. 20 for answer-back drums coded for 1-cycle operation—on 33 Teletypewriter Sets used in systems where a response to each answer-back activation signal must always be obtained. The last row can be coded with any other character that is compatible with the particular system.

Note: Another use which can be made of the character suppression level tines is the elimination of coding errors. If a coding error is made or, for some other reason, if it is necessary to suppress (erase) characters from the answer-back drum, remove the character suppression tine from the row(s) affected.

2.09 As previously stated in 2.07, the character suppression tine in the ST row is removed at the factory. The stop cam tine in row no. 6 is also removed at the factory. These two levels are always coded the same for 1-cycle operation and are part of the coding for the 2- or 3-cycle operation when either is used.

2.10 The number of rows available for message coding is shown below for 1-, 2-, or 3-cycle operation:

CYCLE OPERATION	TOTAL ROWS	AVAILABLE ROWS
1	21	20
2	10 (11)*	9 (10)*
3	7	6

\*Alternately one, then the other.

2.11 The number of rows available for coding a station identification message, however, is less than the number of available rows shown above. A certain number of nonprinting functions such as "carriage return," "line feed," or "letters" must be coded into the answer-back drum to condition a receiving Teletypewriter Set to accept and print the station identification message. Normally, a message must begin and end with "carriage return" and "line feed." This assures one that the transmitted message will appear at the beginning of a line of a receiving Teletypewriter Set, and that overprinting of the message will not occur.

Note: For 5-level operation, the "letters" code combination is also included at the beginning of a transmitted message to place each receiving Teletypewriter Set in the unshift position.

2.12 In Bell System switched network service, the station identification for 1-cycle operation may not exceed 12 characters, including spaces. The answer-back drum should be coded as follows:

ABBREVIATION	KEY TO ABBREVIATION
CR	Carriage Return
LF	Line Feed
RO	Rub Out
SP	Space
SUP	Character Suppression
XON	Tape Reader On

(a) Example 1:

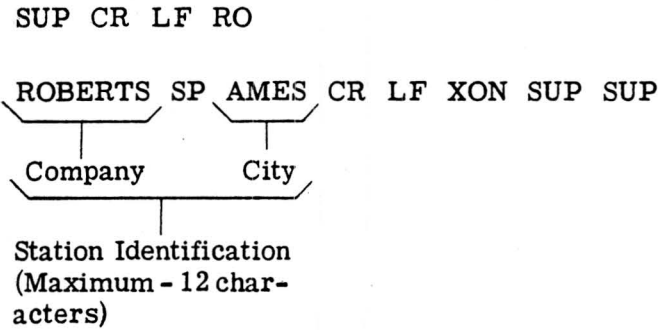

Note: In this System, the XON character code combination must be the final significant character code combination in the coded answer-back message. It may be followed by the "character suppression" code combination only.

(b) Example 2:

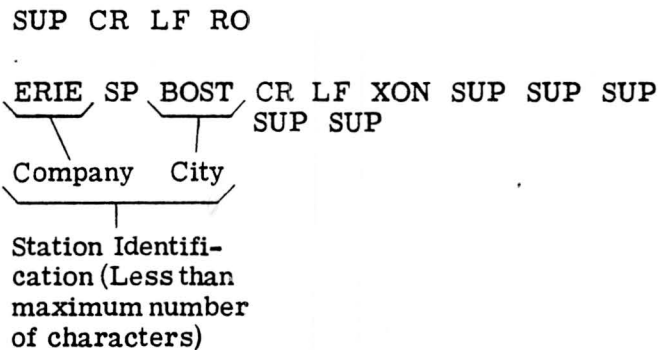

Note: If the station identification is less than the maximum of 12 characters in length, then the remaining rows on the answer-back drum must be coded with the character suppression code according to Example 2 above.

2.13 To replace the answer-back drum, lift the feed pawl and rest the answer-back drum shaft on top of the right and left sides of the contact block. Drop the pawl onto the answer-back drum and rotate the answer-back drum frontward while pulling it toward the rear against the contact springs and detent lever until the shaft drops over the rear of the contact block on the right and left sides. Lower the answer-back drum until the shaft seats into the right and left slots. Rotate the answer-back drum against its detent to assure proper seating of the associated parts. Check that the contact springs are located in their proper slots.

ADJUSTMENTS

2.14 Check DASHPOT ORIFICE (Spacing Area) adjustment, since altitude may have some affect on dashpot operation. Also check DISTRIBUTOR TRIP LINKAGE (Keyboard) and "HERE-IS" ADJUSTING BRACKET (Answer-Back Area) adjustments. See the appropriate typing unit and keyboard sections for adjusting procedures.

2.15 Teletypewriter Sets equipped with an answer-back mechanism must be tested for the obtaining of the proper response when a predetermined call character, such as WRU or FIGS D is transmitted. The following procedure is recommended for performing this test:

- (a) Request back-up station test center to call the station being installed and transmit the predetermined call character signal several times after a connection has been established.
- (b) The station being installed shall answer automatically and transmit the answer-back message when the predetermined call character signal is received.
- (c) The installed station's answer-back mechanism shall respond to the receipt of each predetermined call character signal from the test center.

Note: An exception is 33 Teletypewriter Sets, which have the character suppression time in the last row (2.09 (c)) removed from the answer-back drum.

PLACEMENT

A. Without Stand

2.16 If no stand is included, place the Teletypewriter Set on the surface where it is to be used.

B. With Stand

2.17 Figure 2 illustrates the leveling and anchoring of the stand.

2.18 Place the partially assembled Teletypewriter Set where it is to be used, and check it for rocking. This may be corrected by adjusting the leveling screws located under rear corners of the stand. Tip the stand slightly for access.

Note: Early design Teletypewriter Sets "walk" under certain conditions. Reaction to the carriage returning to its left position may cause early design Teletypewriter Sets to move across the floor toward the left. To correct this, either add weight to the stand, arrange to have it bolted to the floor, or drill one 0.0359 inch diameter hole into each leg and install two TP182285 rubber bumpers, one in each leg.

2.19 If the Teletypewriter Set is to be bolted to the floor, place stand at the desired location and drive lag bolts into the floor through the front holes in the legs.

2.20 Place the relay rack with data set inside the stand.

### ELECTRICAL CONNECTION

CAUTION: MAKE SURE POWER CORD IS NOT CONNECTED.

2.21 Refer to the appropriate wiring diagrams packed with the Teletypewriter Set or to the appropriate wiring diagram section, when provided.

2.22 Connect the signal line leads (supplied by customer) to the terminals on the terminal board at the rear of the call control unit, as indicated in the wiring diagram.

2.23 Where a data set is used, connect the connectors on the cables from the data set to those on the cables from the call control unit. Connect the telephone line and data set power leads to terminals indicated on wiring diagram. Maintain correct polarity.

2.24 Connect polarized power cord to a 115-volt, 60-cycle ac source.

### 3. FINAL ASSEMBLY

#### GENERAL

3.01 Replace the back panel onto the stand, if used, using the removed screws.

Note: On an ASR, before replacing the cover over the typing unit and onto the subbase, remove the retaining ring from the tape reader upstop screw (Figure 10), and the yellow packing clip from under the tape punch sensing lever (Paragraph 7.01).

3.02 Replace the cover over the typing unit and onto the subbase (Figure 1). Take care that all seams are tight and that keyboard pushbuttons, dial, etc, are properly aligned through holes. Insert and tighten three flat head screws at the back and four pan head screws at the front.

Note: On an ASR, insert and tighten the screw at the left rear corner of the tape reader cover.

3.03 Replace the nameplate, making sure that the formed lip fits around the bottom of the flange on the cover, that the top edge is behind the small lip on the cover, and that the bottom of the nameplate rests on top of the two small projections on the subbase.

3.04 Replace the volume control knob, if used, or the power switch rotary knob, if used, positioning and pushing rearward.

3.05 Replace the bezel, if used, over the call control unit. Position the bezel to the cover and insert and tighten two mounting screws.

3.06 On friction feed typing units, align the platen knob with the flat on the left side of the platen, and push it into place. On sprocket feed typing units, assemble the platen knob to the left side of the platen. Fully seat the platen knob to the right, and secure it with the screw provided.

#### RIBBON INSTALLATION

3.07 Figure 5 illustrates ribbon threading.

3.08 Raise the lid on the cover. Pull both spools off the friction spindles.

3.09 Engage the hook that is on the end of the ribbon in the hub of the empty spool; or if there is no hook, pierce the end of the ribbon over the point of the arrow in the hub of the empty spool. Wind a few turns of ribbon onto the empty spool in the direction indicated by the arrow, and make sure that the reversing eyelet has been wound upon the spool.

3.10 Place the spools on the shafts in such a manner that the ribbon feeds to the rear from the right side of the right spool and from the left side of the left spool. Turn each spool slightly until the driving pin on the spool engages the hole in the spool. Pull the ribbon

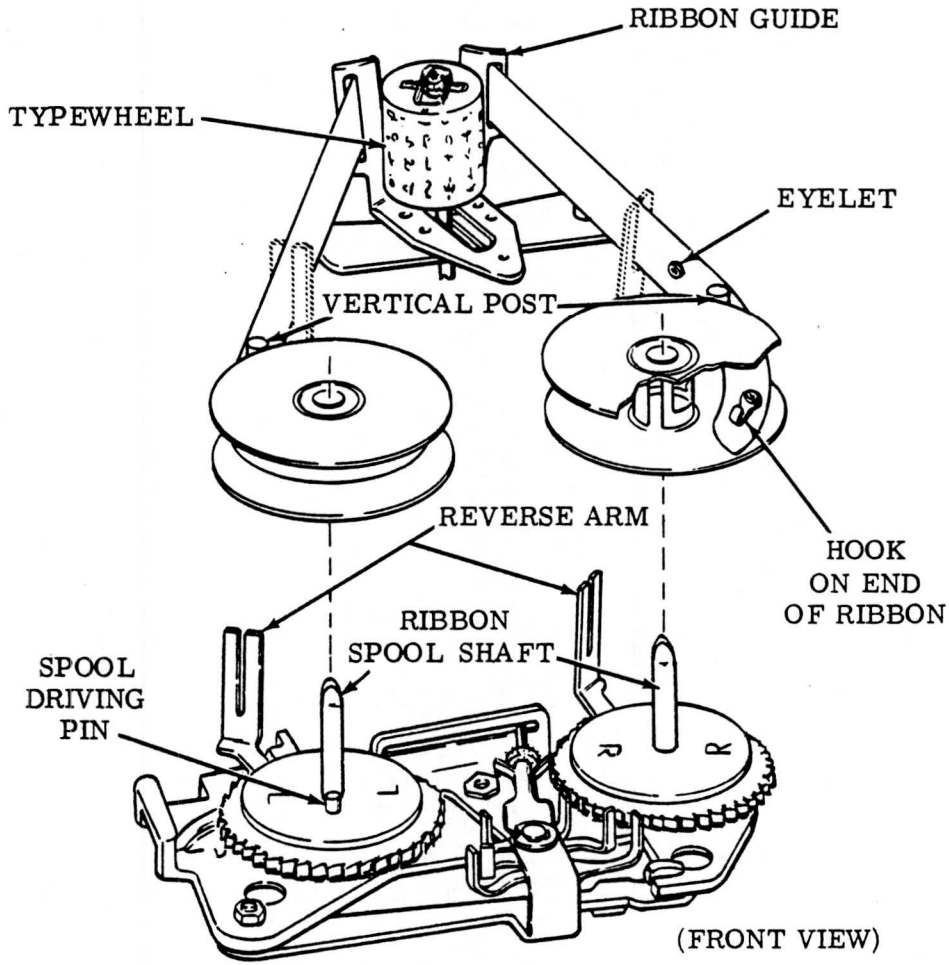

Figure 5 - Ribbon Threading

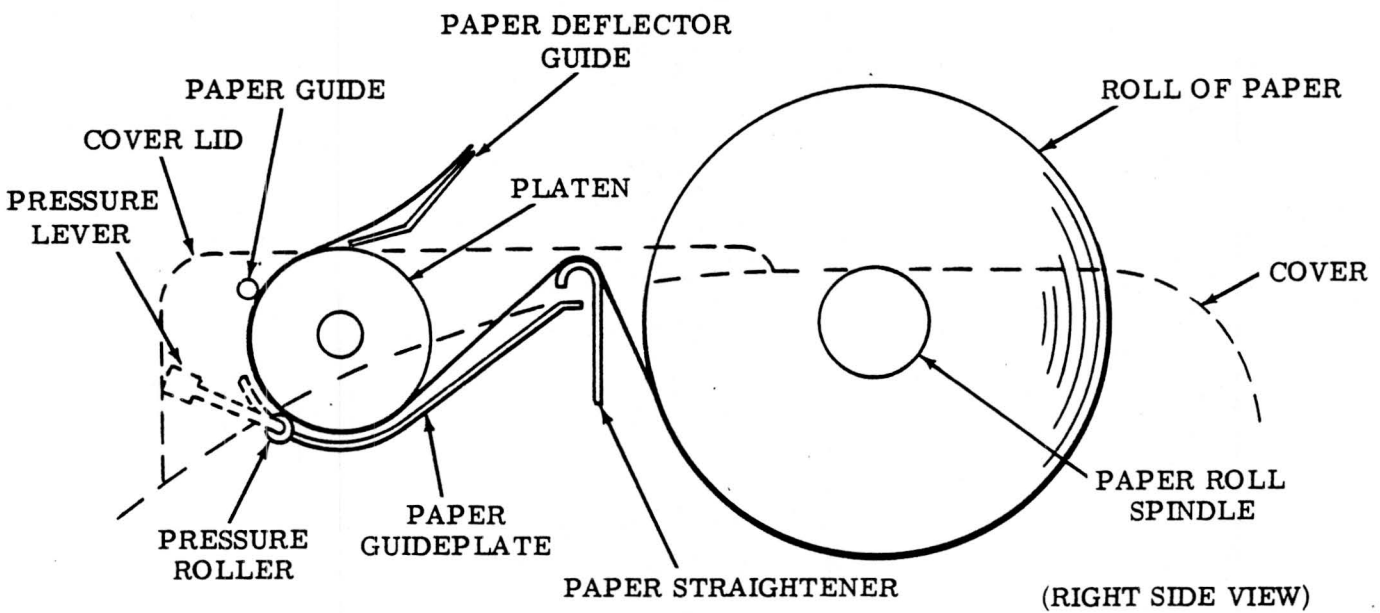

Figure 6 - Paper Threading — Friction Feed

around the right vertical post and through the slot in the reverse arm. Place the ribbon in the right slot of the ribbon guide, around the rear of the guide on both the right and left side, and through the left slot of the guide. Pull it forward on the left side through the reverse arm slot and around the left side of the vertical post. Rotate the spool to take up any slack.

#### PAPER OR FORM INSTALLATION

##### A. Friction Feed

3.11 Figure 6 illustrates paper threading for a friction feed typing unit.

3.12 A friction feed Teletypewriter Set accommodates a standard roll of paper 8-1/2 inches wide and 5 inches in diameter.

3.13 Insert the paper roll spindle into the roll of paper so that an equal length of spindle is exposed at either end of the roll.

3.14 Place the roll of paper into the paper recess of the cover so that the ends of the paper roll spindle rest in slots provided, and so that the paper will unroll forward from the bottom.

3.15 Raise the lid on the cover. Fold the leading edge of the paper back and crease it to present a smooth edge when threading it. The paper should unroll from the bottom of the roll, pass forward and up, over the paper straightener, and down and under the platen. Release the pressure roller tension by moving the pressure lever forward. Push the paper in as far as it will go. Reapply the pressure roller tension and advance the paper by turning the platen knob clockwise, as viewed from the right, until the paper can be passed under the paper guide. Release the tension on the pressure roller again, and straighten the paper. Reapply the pressure roller tension to hold the paper in place. Close the cover lid.

Note: When typing units are stored or out of service for an extended period of time, release the pressure roller tension by moving the pressure lever forward.

##### B. Sprocket Feed

3.16 A Teletypewriter Set, sprocket feed, accommodates forms 8-1/2 inches wide and of various lengths. The forms are normally

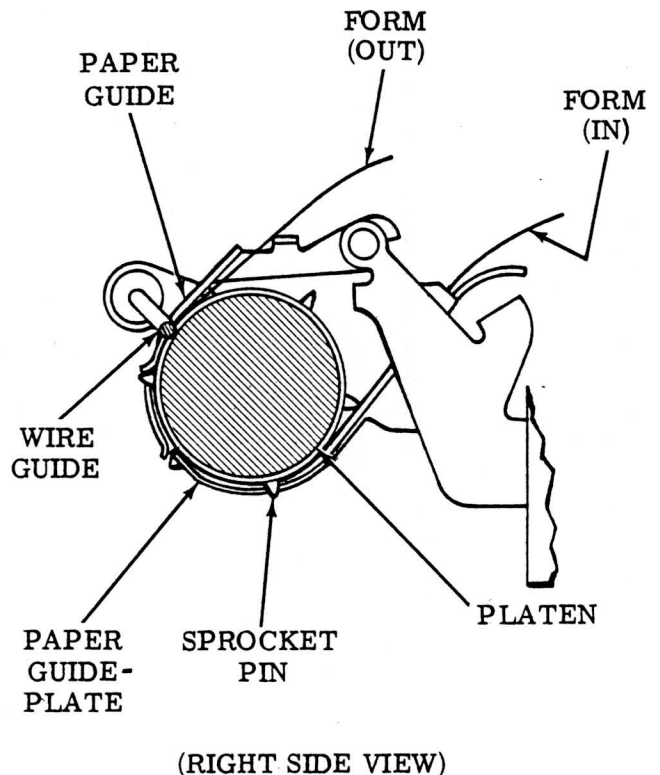

Figure 7 - Form Threading — Sprocket Feed

passed to the typing unit from a conveniently located stack of forms.

3.17 Place the paper roll spindle into the paper recess of the cover so that the ends of the paper roll spindle rest in the slots provided in the cover.

3.18 Figure 7 illustrates form threading for a sprocket feed typing unit.

3.19 Form Threading: Raise the lid of the cover. Get the leading form from a stack of forms, and pass it under the paper roll spindle—leading edge first. Thread the form under the low-paper and paper-out arms, if used, and between the platen and paper guideplate. Guide the form squarely into the platen and, with the plunger of the platen knob depressed, gently rotate the platen clockwise, as viewed from the right side, until the form is advanced by the sprocket pins beyond the forward edge of the paper guideplate. Lift up the wire guide with the two paper guides, and continue to rotate the platen clockwise, as viewed from the right side, until the form is fully engaged by the sprocket pins. Lower the

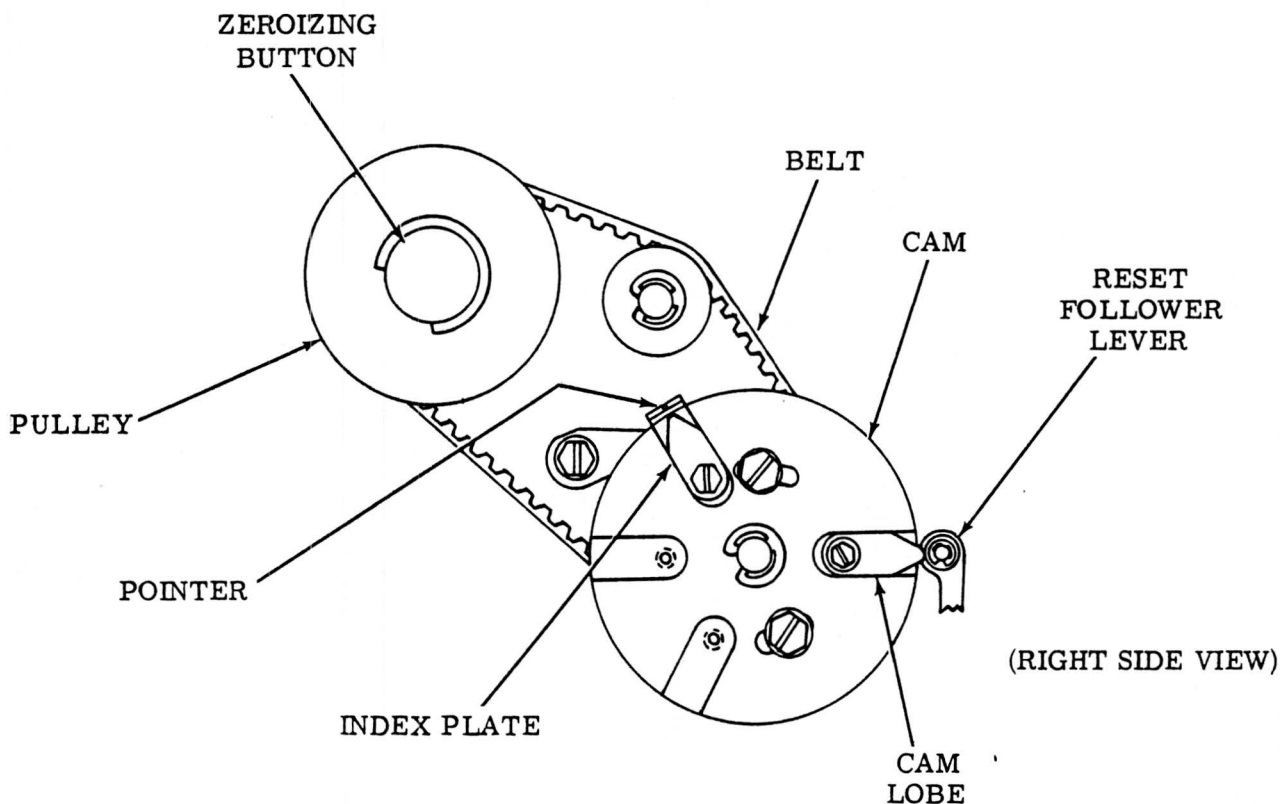

Figure 8 - Zeroizing Position of Platen Drive Mechanism — One Cam Lobe Operation

wire guide with the two paper guides. Rotate the platen further to position the form for the first typing line. After the first form is fed out, lift the form over the paper roll spindle to separate the incoming forms from the outgoing forms.

3.20 Figure 8 illustrates the zeroizing position of the platen drive mechanism for one cam lobe operation. For the zeroized position of the platen drive mechanism using more than one cam lobe, see the CAM ZERO POSITION (Platen Drive Area, Sprocket Feed Mechanism) adjustment in the appropriate typing unit adjustment section.

3.21 Zeroized Position: With a form positioned in the typing unit at its first printing line, depress the zeroizing button, located on the right side of the platen, to the left. Rotate the pulley until the index plate or cam lobe on the cam at the platen drive mechanism is lined up with the pointer. Line up either the index plate or a cam lobe with the pointer, depending whether one, two, or three cam lobes are being used (3.20). Release the zeroizing button, and the platen

drive mechanism along with the associated form-out mechanism is in its zeroized position—set to advance a form to the first printing line of the next form.

Note: To initiate the action to feed out a form, depress the FIGS Z keytop on 5-level Teletypewriter Sets or the CTRL FORM keytop on 8-level Teletypewriter Sets. The form-out mechanism will not respond to successive commands to feed out a form. At the end of a form feed-out, advance the form at least one line before issuing a second form-out command.

#### 4. OPTIONAL FEATURES

##### COPY HOLDER

4.01 Figure 9 illustrates the copyholder.

4.02 Stand at the rear of the Teletypewriter Set. Hold the copy holder so that the line guide faces frontward. Locate the four mounting slots in the cover, two on either side of the paper mounting recess. Tilt the copy holder toward the rear, and partially insert

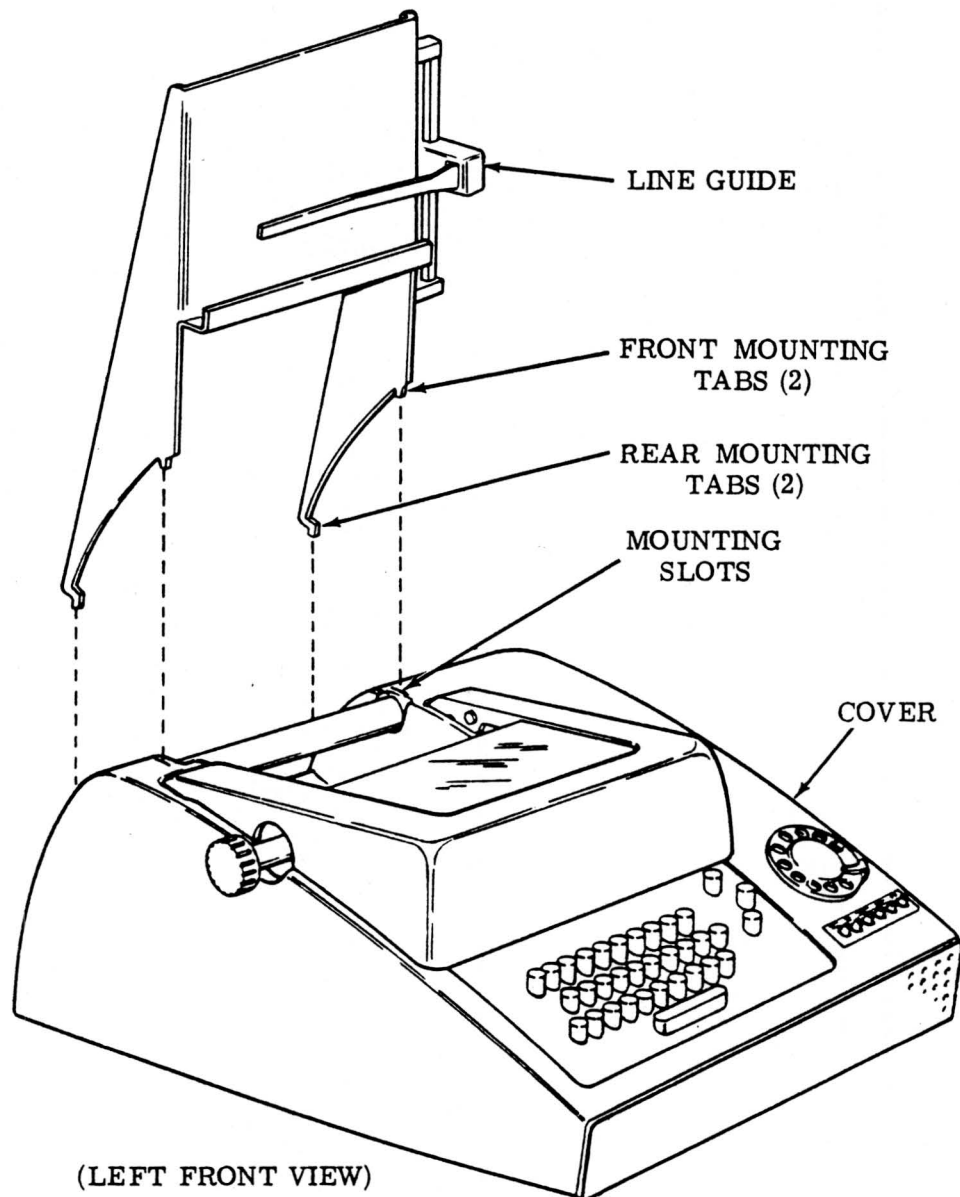

Figure 9 - Copy Holder

the rear right and left tabs on the copy holder onto the respective rear right and left slots. Pivot the copy holder forward until the front right and left tabs align with the front right and left slots. Push downward on the copy holder until the tabs are fully seated.

#### HUM SQUELCH

4.03 When the Teletypewriter Set is not in use, the J1D101A data set produces a hum through the loudspeaker. Also, the time-

clock synchronization signals can be heard. To squelch these, modify the wiring on J1D101A data set as follows:

- (a) Remove from terminal no. 50 on the terminal board the black-green lead going to the 50-pin connector.
- (b) Add a length of wire to the removed lead and connect it to the common contact no. 7 of CON relay. Insulate the splice with tape.

(c) Add a lead connecting the normally closed contact no. 7 of CON relay to the common contact no. 5 of OR relay.

(d) Add a lead connecting the normally open contact no. 5 of OR relay to terminal no. 50 on the terminal board.

**BUSY CIRCUIT**

4.04 The 33 Teletypewriter Set is normally wired in a "do not answer" mode of operation for low-paper alarms and out-of-service. In this mode, the Teletypewriter Set will not answer an incoming call. To wire the Teletypewriter Set to indicate "busy" instead of not answering, move the BK-S wire from terminal no. 2 to terminal no. 4 on the ringer terminal strip.

**HAND RECEIVER**

4.05 To install the hand receiver, connect two white wires to terminals no. 5 and 6 on the 9-point terminal board.

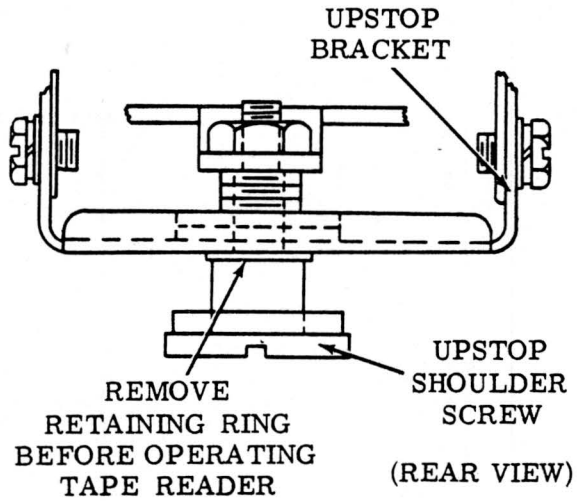

Figure 10 - Tape Reader Upstop Bracket Retaining Ring

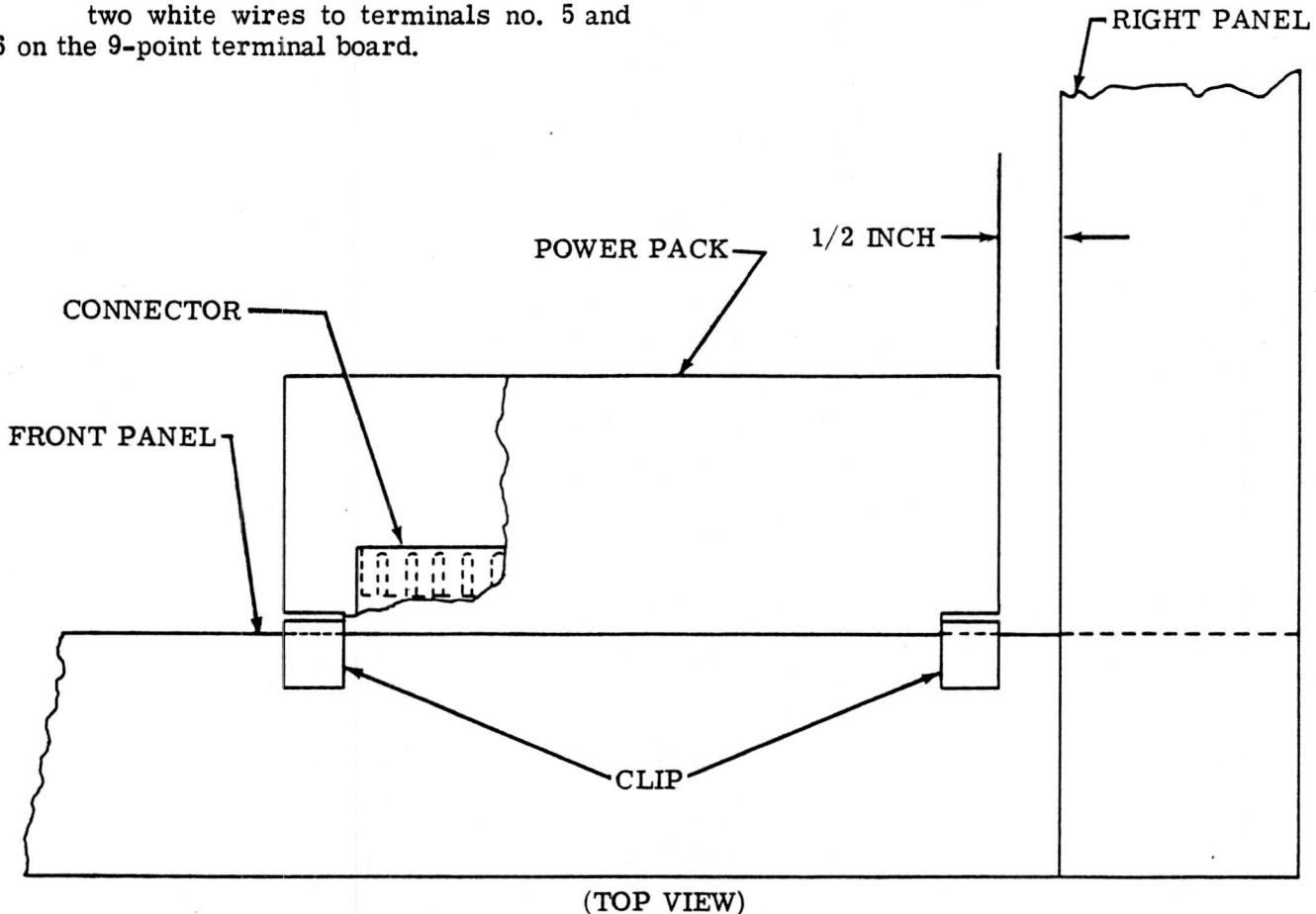

Figure 11 - Power Pack Assembly

5. TAPE READER

5.01 A retaining ring (Figure 10) is assembled to the upstop screw to prevent the sensing pins from being dislodged during shipment. This retaining ring must be removed before placing the tape reader in operation. Check the packing instructions.

5.02 When inserting tape into the tape reader prior to operation, allow enough slack in the tape between the tape punch and the tape reader so that the tape reader lid can be easily closed.

**CAUTION:** THE TAPE READER OPERATES UNDER HIGH VOLTAGE. PRECAUTIONARY MEASURES SHALL BE TAKEN WHENEVER POWER TO THE TAPE READER IS TURNED ON. HIGH VOLTAGE FROM THE POWER PACK WILL CONTINUE UNTIL APPROXIMATELY 10 SECONDS AFTER THE TAPE READER HAS BEEN DISCONNECTED.

5.03 While the tape reader is operating under power, do not push the control lever beyond the STOP position. When it is necessary to place the control lever into the FREE position, wait until the tape reader has stopped before pushing the control lever there.

6. POWER PACK ASSEMBLY

6.01 The power pack assembly (Figure 11) is snapped on, with two clips assembled to the power pack, to the front panel of the stand. Position the power pack so that it shall be spaced approximately 1/2 inch from the right panel of the stand.

6.02 The auxiliary ASR power supply is mounted in the enclosure of the stand. It is used in the off-line mode to provide 115 volts on the tape reader, keyboard, answer-back, and distributor contacts only when a tape reader is used. When the tape reader is not used, a dummy plug with a jumper wire is in-

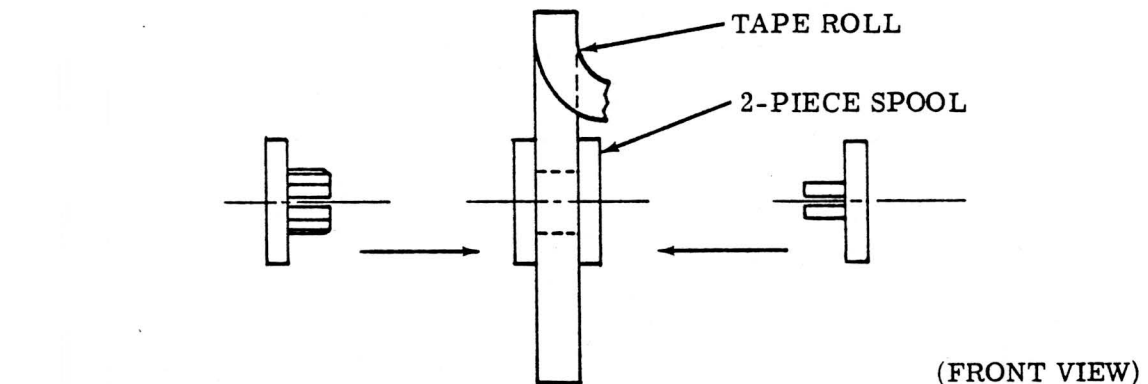

2-PIECE SPOOL  
FOR 1-INCH INSIDE DIAMETER TAPE ROLLS

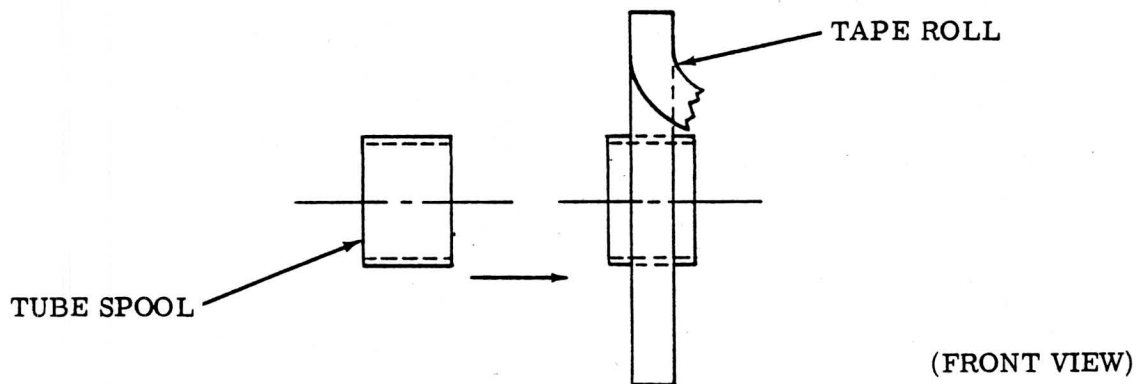

TUBE-TYPE SPOOL  
FOR 2-INCH INSIDE DIAMETER TAPE ROLLS

Figure 12 - Tape Roll and Tape Spool Assembly

serted in position R2 at the rear of the call control unit.

7. TAPE PUNCH

7.01 The tape punch, drive link mechanism, base casting, and plastic cover are all assembled together at the factory on 32 or 33 Teletypewriter Sets. However, before the ASR is shipped, a yellow packing clip is assembled under the sensing levers and behind the 0 codebar extension between the tape punch base casting and the left codebar extension guide. During the installation, remove the composite typing unit and tape punch cover assembly (1.07 and 3.01), and remove the yellow packing clip. It is very important that the clip is removed prior to operating the tape punch. Check the packing instructions.

7.02- Figure 12 illustrates the proper installation of a tape roll onto a tape spool assembly.

- (a) For the 2-inch inside diameter tape roll, use the tube-type spool.
- (b) For the 1-inch inside diameter tape roll, use the 2-piece spool.
- (c) Assemble the tape with the spool into the tape punch cover so that the leading edge of the tape is always at the top of the roll.

7.03 Figure 13 illustrates how the chad box assembly should be installed.

- (a) Assemble the chad box under the tape punch pan by inserting the back of the flanged surface between the stand and the typing unit subbase.
- (b) Push the chad box towards the rear until a bent surface located at the front of the chad box engages the stand. An embossing located on the front bottom surface of the flanged surface engages an oblong hole in the stand and holds the chad box in place.
- (c) To empty the chad box, lift the front slightly and pull the chad box towards the front until it becomes disengaged.

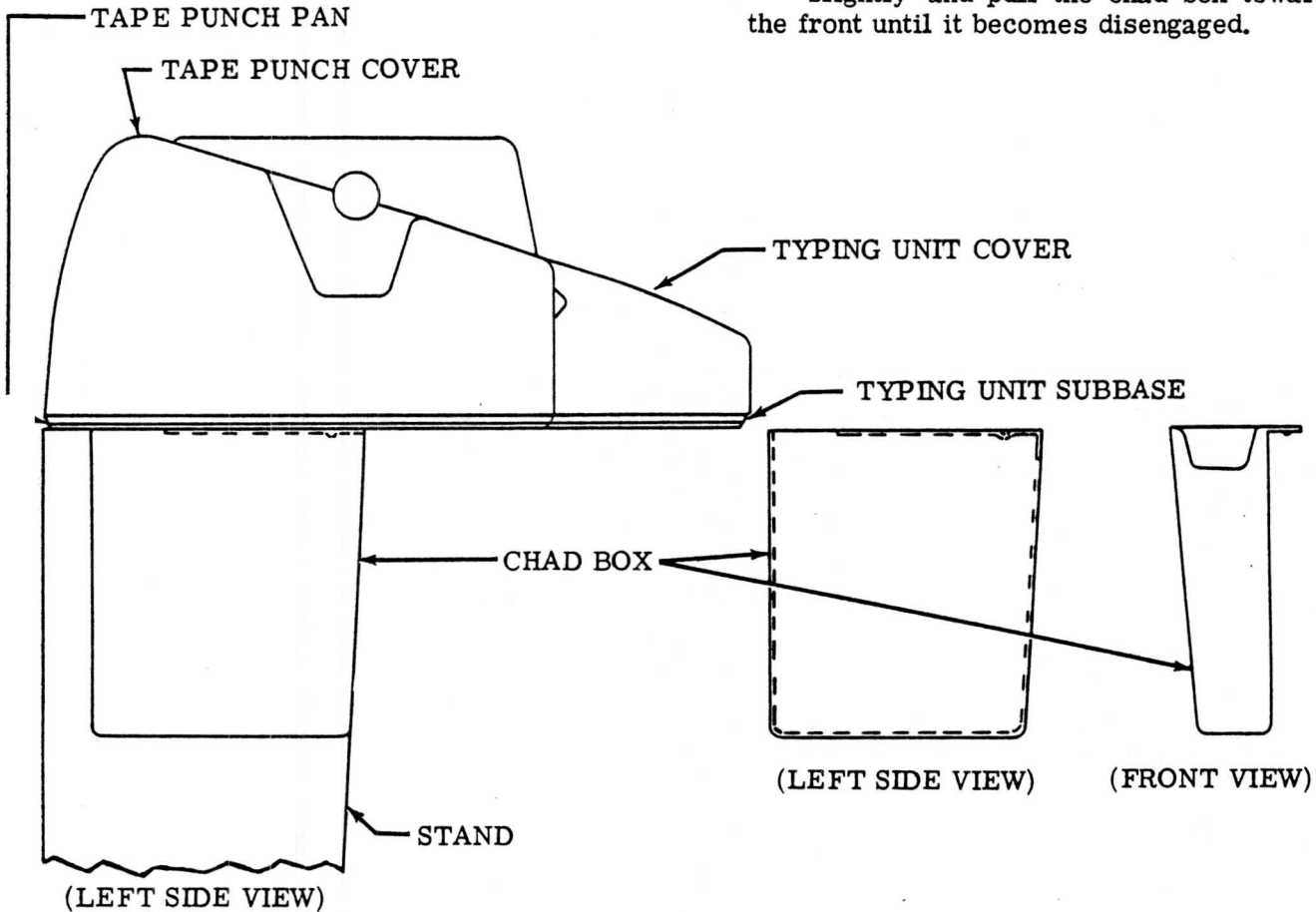

Figure 13 - Tape Punch Chad Chute Assembly

32 AND 33 KEYBOARD

PRINCIPLES OF OPERATION

CONTENTS	PAGE
1. GENERAL . . . . .	1
2. TRANSMISSION . . . . .	1
GENERAL . . . . .	1
KEYBOARD . . . . .	1
A. Codebar Mechanism . . . . .	1
B. Universal Mechanism . . . . .	3
C. Keyboard Contact Mechanism. . . . .	4
D. Line Break. . . . .	4
E. Repeat. . . . .	4
EXAMPLE . . . . .	4
A. General . . . . .	4
B. 32 Keyboard . . . . .	5
C. 33 Keyboard . . . . .	6

1. GENERAL

1.01 This section is issued to provide principles of operation for the 32 and 33 keyboard and to present the principles as a separate section.

1.02 The teletypewriter code used to transmit messages is described in the appropriate typing unit section. This keyboard section outlines in general terms the overall operation of the keyboard and explains in detail the operation of the components that make it up.

1.03 References to "left," "right," "front," or "rear," etc, consider the keyboard to be viewed from a position where the spacebar faces up and the contact mechanism is located to the viewer's right.

1.04 In the illustrations, fixed pivots are solid black, and floating pivots—those mounted on parts that move—are cross-hatched.

2. TRANSMISSION

GENERAL

2.01 Transmission of messages is accomplished by an operator selectively depressing the keys and spacebar of the keyboard in the same manner as in typing. The downward movement of each key or the spacebar is translated by a codebar mechanism into mechanical arrangement corresponding to the code combination representing the character on the keytop. The mechanical arrangements set up the code combinations in a set of keyboard contacts, and, by parallel output, the code combinations are transmitted to a distributor mechanism. A universal mechanism trips a distributor clutch, and a distributor mechanism then translates the parallel output from the keyboard contacts into corresponding start-stop signal for application to the transmission facilities.

Note: For a further discussion of transmission principles, see the appropriate typing unit section.

KEYBOARD

2.02 In conjunction with a distributor mechanism, the keyboard provides facilities for transmitting messages by the manual operation of a group of keys. The 32 and 33 keyboards are described in the appropriate keyboard section.

A. Codebar Mechanism

2.03 The codebar mechanism is illustrated in Figure 1.

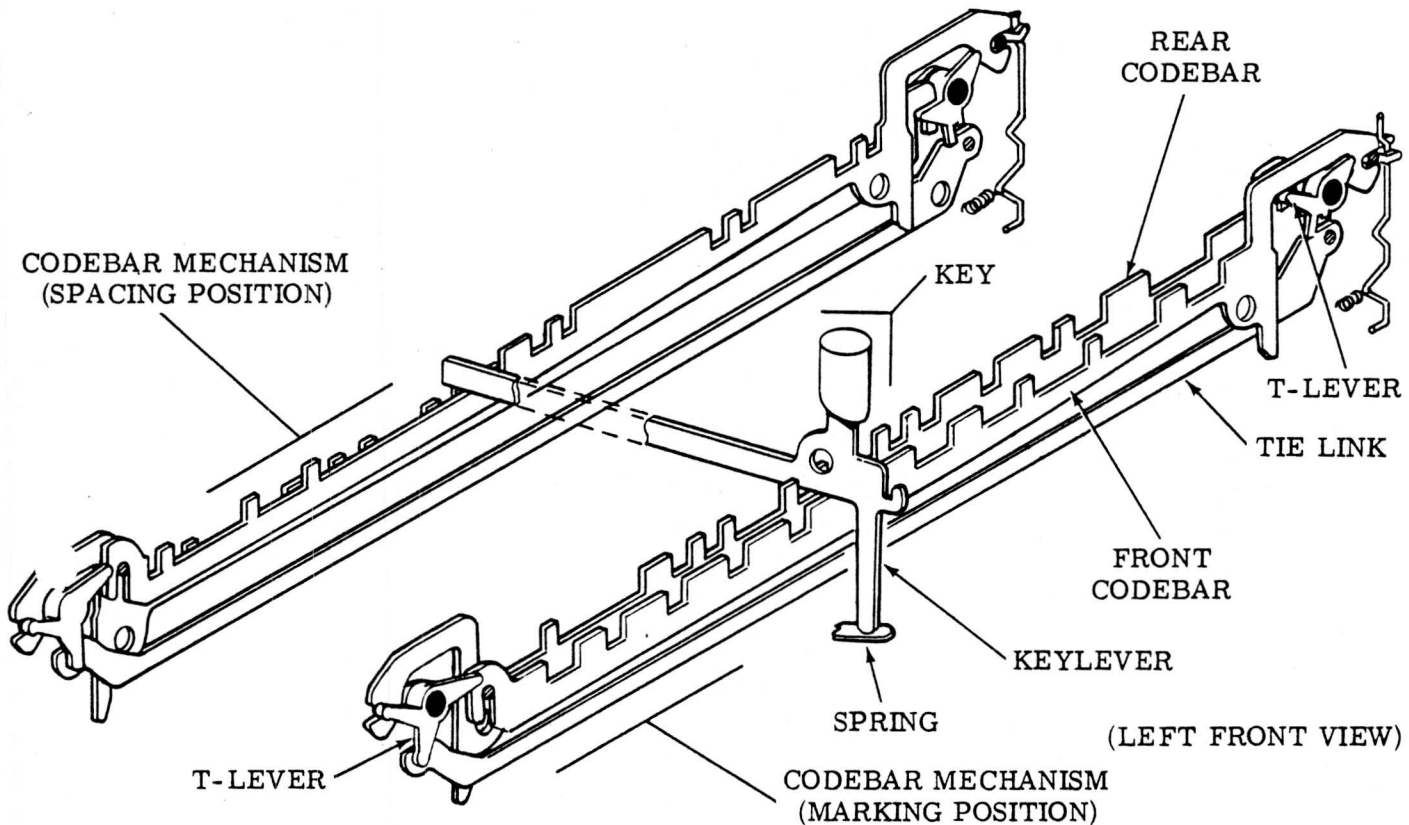

Figure 1 - Codebar Mechanism

2.04 For each intelligence element of the code, there is a codebar submechanism which consists of a front codebar, rear codebar, a tie link, and two T-levers. The mechanisms are numbered from rear to front according to the corresponding code elements—1 through 5 for the 32 keyboards and 1 through 8 for 33 keyboards. In addition, there is a universal codebar mechanism (Figure 2), consisting of one codebar, a tie link, and two T-levers.

2.05 The codebars have slots in their top edges which codes them so they are selectively depressed by the keys' keylevers. Each mechanism has a marking and a spacing position. In the marking position, the front codebar is down, the rear codebar is up, and the right T-lever is in the clockwise position. The spacing position is the opposite: front codebar up, rear codebar down, and right T-lever in counterclockwise position.

2.06 The two codebars in each mechanism are complementary coded so that, at any keylever position, where one has a slot, the

other is solid. When a key is depressed, it is returned to its up position by a leaf spring. However, the code combination representing the key's character remains in the codebar mechanisms. When a new key is depressed, only the mechanisms whose code elements differ from those of the preceding combination are operated as illustrated.

2.07 Assume that a letter has just been transmitted—"S" for a 32 keyboard or "E" for a 33 keyboard. The "S" (1-3-- ) or "E" (1-3---78) code combination remains in the codebar mechanisms. Now assume that another key is depressed—"D" (1--4-) for a 32 keyboard or "I" (1--4--78) for a 33 keyboard. The keylever of the key depressed encounters a slot in the rear codebar of the no. 1 codebar mechanism of the 32 keyboard or the no. 1, 7, and 8 codebar mechanisms of the 33 keyboard. Thus, the codebar mechanisms remain marking. In the case of the no. 2 and 5 codebar mechanisms for the 32 keyboard or the no. 2, 5, and 6 codebar mechanisms for the 33 keyboard, the keylever encounters a slot in the front codebar, and they remain spacing.

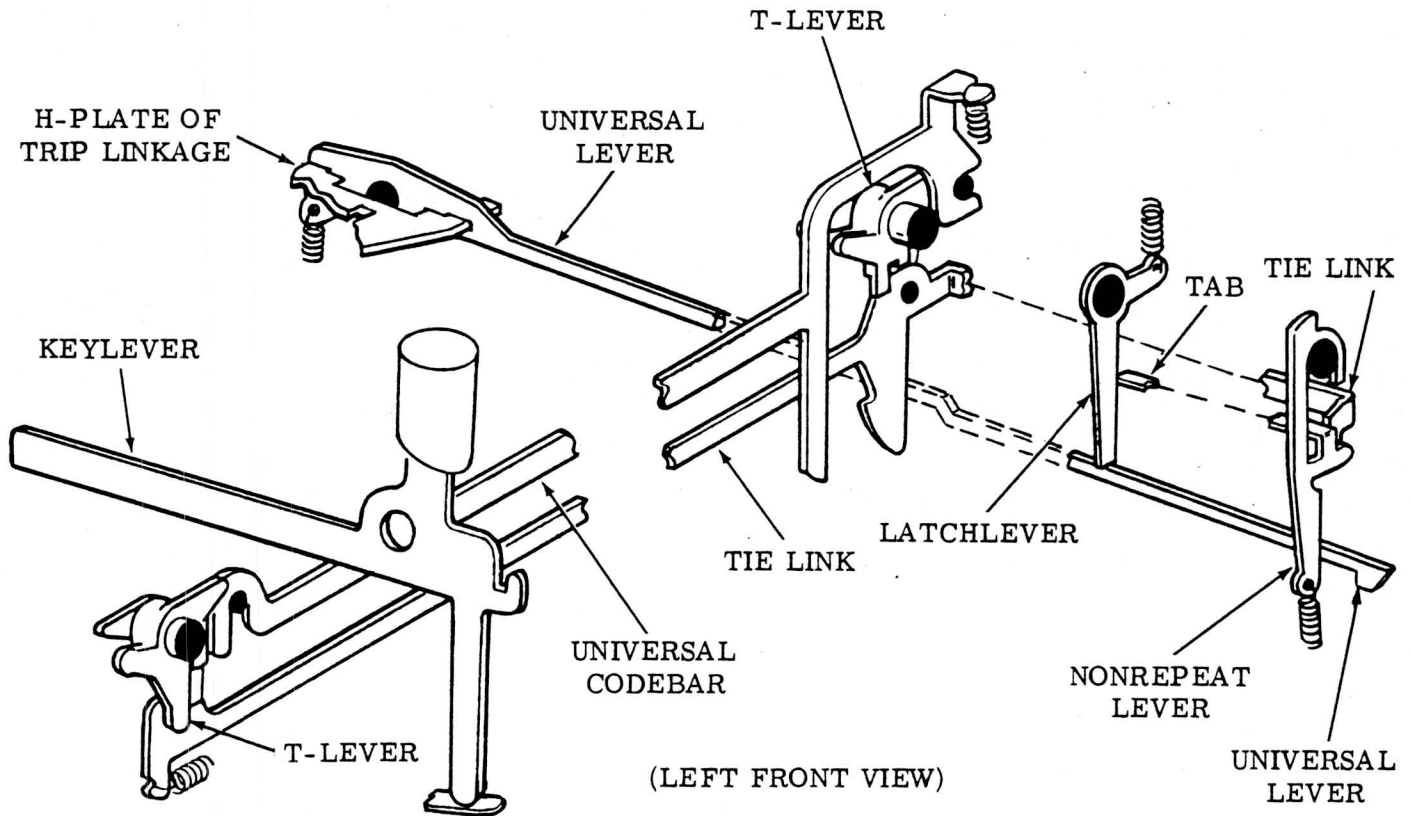

Figure 2 - Universal Codebar Mechanism

In the case of the no. 3 codebar mechanism in either the 32 or 33 keyboard, the keylever encounters the solid portion of the rear codebar and shifts it to its spacing position. In a similar manner, the keylever encounters the solid portion of the front codebar of the no. 4 codebar mechanism of either the 32 and 33 keyboard and shifts it to the marking position.

2.08 Since each code combination is different and is locked in the codebar mechanisms, the complementary coding of the codebars serves as an interlock for the keylevers. When one keylever is depressed, another cannot be depressed because it will be blocked by the solid portion of one or more codebars.

#### B. Universal Mechanism

2.09 The universal codebar mechanism is illustrated in Figure 2.

2.10 As a keylever nears the bottom of its travel, it depresses a codebar which is part of the universal codebar mechanism.

The codebar, in turn, causes associated T-levers to pivot and a tie link to move to the left. After some free movement, the tie link encounters a tab on a nonrepeat lever and pivots the latter to the left. The tab, in turn, pivots a latchlever which releases a universal lever. Under spring pressure, the universal lever moves up and lifts the nonrepeat lever so that its tab is moved from between the universal tie link and the latchlever. Under spring pressure, the latchlever and nonrepeat lever move back to the right to their unoperated position.

2.11 In its up position, the universal lever locks the right intelligence T-levers in the positions set up by the keylever, permits a contact bail to pivot to its down position and, through a trip linkage, trips the distributor clutch. Near the end of the distributor cycle, the trip linkage moves the universal lever back to its down position where it is latched by the latchlever.

2.12 Should the keylever remain depressed beyond the end of the distributor cycle, when the universal lever moves to its down

position, the nonrepeat lever under spring tension moves down until it hangs up on the top of the universal tie link which is still in its left position. When the keylever is finally released, the tie link moves back to the right and permits the nonrepeat lever to move all the way down so that its tab is again between the tie link and the latchlever. The trip mechanism operates in this way to prevent the distributor clutch from being retripped when a keylever is held down.

### C. Keyboard Contact Mechanism

2.13 The keyboard contact mechanism is illustrated in Figure 3.

2.14 The codebar mechanisms set up the code combinations in a set of keyboard contacts. A contact wire is associated with each right T-lever excluding the universal. In the stop condition of the keyboard, a contact bail is held in its up position by the universal lever, and, in turn, holds the contact wires to the right away from the T-levers.

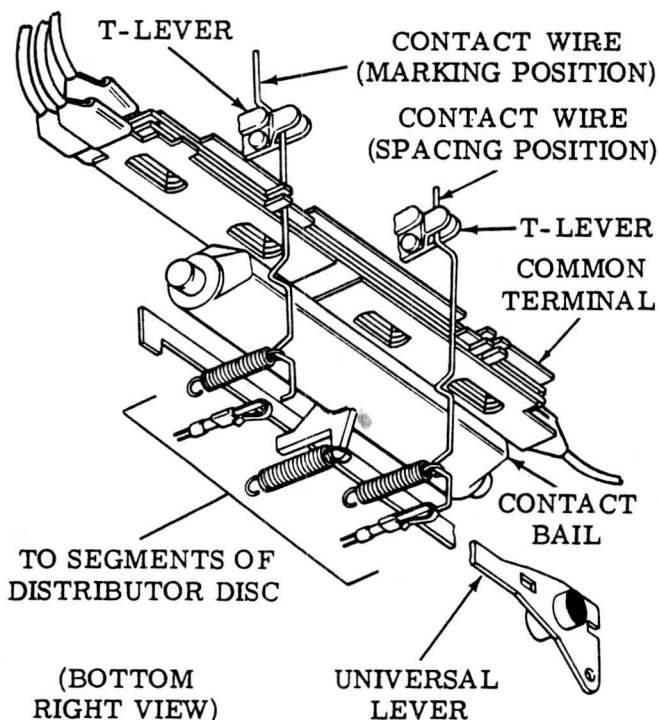

Figure 3 - Keyboard Contact Mechanism

2.15 When a keylever is depressed, a code combination is set up in the codebar mechanisms. The universal lever moves to its up position and permits the contact bail to pivot under spring pressure to its down position. The contact wires associated with the T-levers that are in the marking (clockwise) position are permitted under spring pressure to move to the left against a common terminal. Those associated with the T-levers that are in the spacing (counterclockwise) position are held to the right away from the terminal. For example, if a code combination—"D" (1--4-) for a 32 keyboard or "I" (1--4--78) for 33 keyboard—is in the codebar mechanism as described in 2.07, the no. 1 and 4 contact wires for a 32 keyboard or no. 1, 4, 7, and 8 contact wires for a 33 keyboard are against the common terminal. Similarly the no. 2, 3, and 5 contact wires for a 32 keyboard or the no. 2, 3, 5, and 6 contact wires for a 33 keyboard are away from the common terminal.

2.16 The distributor mechanism converts these positions to start-stop signals. Near the end of the distributor cycle, the universal lever moves back to its down position and pivots the bail to its up position. The bail, in turn, cams the contact wires back to the right and holds them there in the stop position.

### D. Line Break

2.17 When a BREAK key is depressed, it pivots a T-lever which opens the break contact (Figure 5). This action opens the signal line until the BREAK key is released.

### E. Repeat

2.18 To repeat the transmission of a character, its keylever is held down along with the REPT keylever. The latter holds the nonrepeat lever down where its tab remains between the tie link and the latchlever (Figure 2). The latchlever is held in its left position and does not latch the universal lever at the end of the cycle. The universal lever thus moves up and trips the distributor clutch causing the character to be retransmitted as long as the REPT key is depressed.

### EXAMPLE

#### A. General

2.19 In the stop position, the distributor clutch is disengaged, and the outer brush rests on the distributor disc stop segment.

When a key is depressed, the proper code combination is set up in the keyboard contacts and the universal lever moves to its up position. The motion of the transfer lever is conveyed by an H-plate to a distributor trip linkage on the typing unit. The trip linkage pivots a trip bail which carries a trip lever rearward out of the way of the distributor clutch's shoe lever. The clutch engages and rotates the distributor shaft and brush holder. The outer brush passes over the distributor disc segments on the outer disc in the following order: (1) start, no. 1 through no. 5, and stop for 32 typing units; and (2) start, no. 1 through no. 8, and stop for 33 typing units. Near the end of the distributor shaft's revolution, a roller on the distributor clutch's disc pivots a follower lever which moves the trip bail and lever frontwards. This motion is transferred through the trip linkage and H-plate to the universal lever which is moved to its down position, where it is latched. When the distributor clutch completes its revolution, the shoe lever strikes the trip lever, and the distributor clutch disengages.

2.20 The effect of the above operation is to apply a start-stop code combination to the signal line corresponding to the combination set up in the keyboard contacts.

B. 32 Keyboard

2.21 Figure 4 illustrates a 32 Keyboard arrangement. Figure 5 is simplified schematic of the signal wiring of the 32 keyboard contacts.

2.22 In the stop position, the outer brush rests on the stop distributor disc segment, and current flows in the signal circuit which is closed (the path being from one side of the line through the start distributor disc segment, the inner distributor disc, the brushes, the stop distributor disc segment, the common terminal, and the break contact to the other side of the line). Thus a marking condition exists. Assume again that the "D" key is depressed. The (1--4-) code combination is set up in the keyboard contacts.

2.23 The distributor clutch is tripped, and the brush holder begins its revolution. While the brush is on the start distributor disc segment, the circuit is open, no current flows, and a spacing element is transmitted. While it is on the no. 1 distributor disc segment, the circuit is closed (the signal path being through the start distributor disc segment, the inner distributor disc, the brushes, the no. 1 distributor disc segment, the closed no. 1 contact, the common terminal, and the break contact); thus current flows, and a marking element is transmitted. While the brush is on the no. 2 and no. 3 distributor disc segments, since the no. 2 and no. 3 contacts are open, the circuit is broken, and no current flows and spacing elements are transmitted. In a similar manner, a no. 4 marking element and a no. 5 spacing element are transmitted. When the brush reaches the stop distributor disc segment, the distributor clutch is disengaged, and the line again becomes marking.

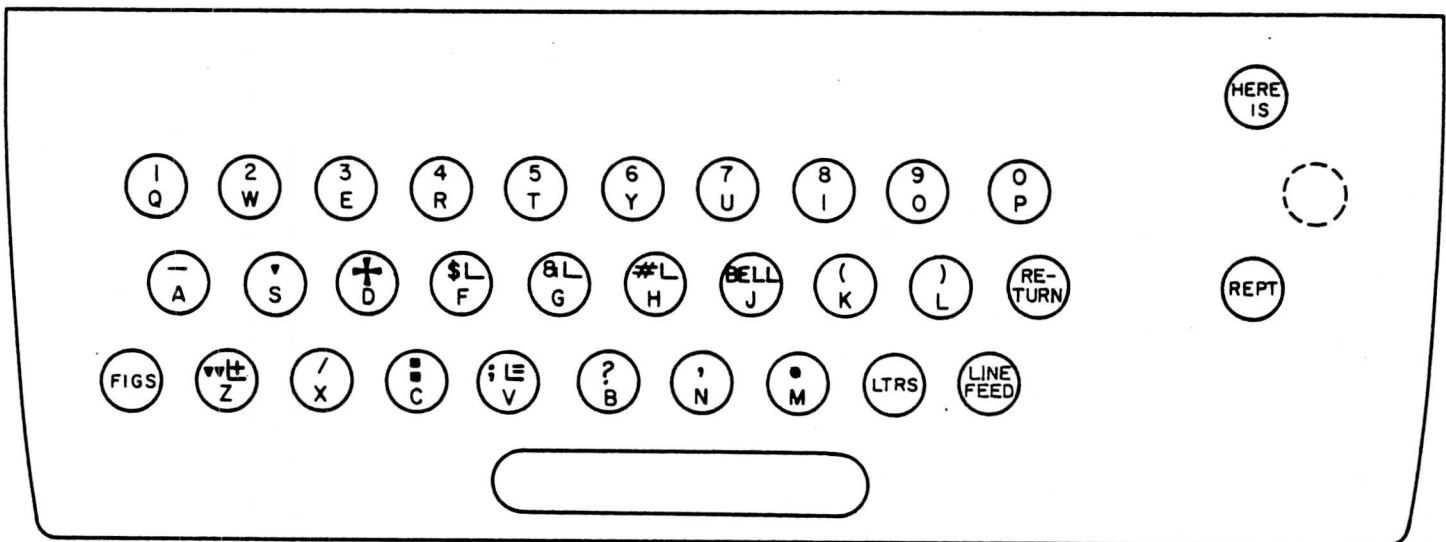

Figure 4 - 32 Keyboard Arrangement

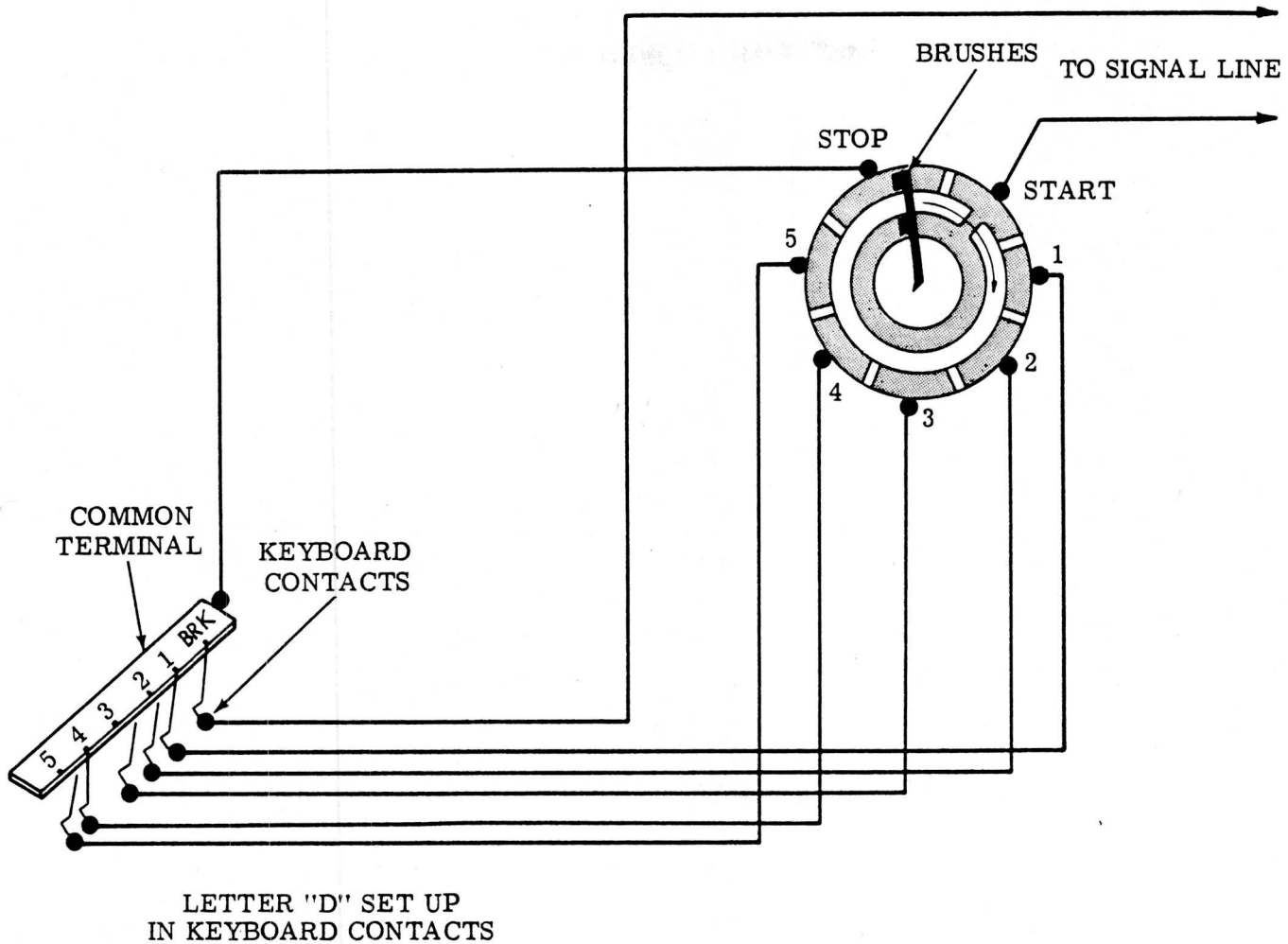

Figure 5 - Signal Wiring - 32 Keyboard Contacts

### 33 Keyboard

2.24 Figure 6 illustrates a 33 keyboard arrangement. Figure 7 is a simplified schematic of the signal wiring for the 33 keyboard (without "even parity").

2.25 Transmission on 33 keyboards is similar to that on 32 keyboards, except that facilities are provided on the keyboard and distributor to generate the American Standard Code for Information Interchange (ASCII). The keyboard utilizes two SHIFT keys and one CTRL (control) key. The SHIFT key is used to generate the code combinations for printing characters appearing on the upper keytops (eg, "\$" that appears above "4" on the keytop in Figure 6). The CTRL key is used to generate the codes for the control characters appearing on the upper keytops (eg, "WRU"

that appears above "E" on the keytop in Figure 6). Simultaneous use of both CTRL and SHIFT keys allows access to special control functions, such as "S5." In every case, the SHIFT and/or CTRL keys must be held down while the appropriate character key is depressed.

Note: Simultaneous depression of the CTRL and SHIFT keys accomplishes the following:

- (a) The no. 5 code element is inverted. If the code element is normally marking, it becomes spacing. If the code element is normally spacing, it becomes marking.
- (b) On 33 keyboards featuring "even parity," the no. 6 code element is converted from marking to spacing.
- (c) The no. 7 code element is converted from marking to spacing.

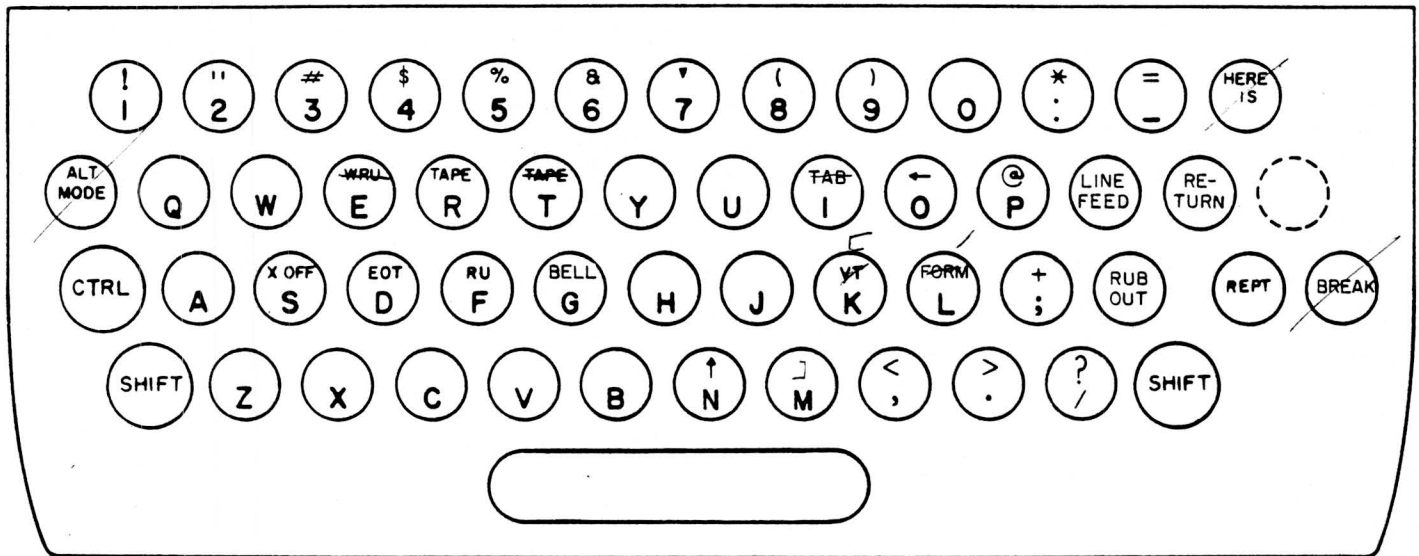

Figure 6 - 33 Keyboard Arrangement

(d) On 33 keyboards featuring "even parity," the no. 8 code element is inverted and reinverted, giving a "normal" no. 8 code element.

2.26 The SHIFT key inverts the no. 5 code element on all 33 keyboards. If the element is normally marking, it makes it spacing; if the element is normally spacing, it makes it marking. It does this by two 2-headed T-levers, one at the shift position, and one at the no. 5 position, each of which operates two contact wires, alternately opening one and closing the other. As shown in Figure 7, in the spacing condition, the "c" contact associated with the no. 5 T-lever is open, and the "d" contact is closed. In its unoperated position, the "a" contact associated with the SHIFT T-lever is closed, and the "b" contact is open. For example, if the "4" key alone is pressed, the code combination for "4" (--3-56-8) is set up in the keyboard contacts and subsequently transmitted. In this case, the 2-headed no. 5 T-lever holds the "c" contact closed and the "d" contact open, resulting in a marking no. 5 code element. (The signal path is through the stop distributor disc segment, the common terminal, the closed "c" contact, the closed "a" contact, the no. 5 distributor disc segment, the brushes, the inner distributor disc, and the start distributor disc segment, as shown in Figure 7.)

2.27 If the "4" key is depressed with the SHIFT key, the same condition is set up in the keyboard contacts, except that the 2-headed shift T-lever holds the "a" contact open and the "b" contact closed and thus opens the signal circuit. This results in the no. 5 code element being spacing rather than marking, and the code combination for "\$" (--3--6-8) being transmitted.

2.28 If the "N" key alone is depressed, the code combination for "N" (-234--78) is set by the codebars and subsequently transmitted to the line. In this case, the 2-headed no. 5 T-lever holds the "c" contact open and the "d" contact closed. On the other hand, if the "N" key is depressed with the SHIFT key, the same condition is set up in the keyboard contacts as before, except that the SHIFT key opens the "a" contact and closes the "b" contact and thus closes the signal circuit. This results in the no. 5 code element being marking rather than spacing and the code combination for (-2345-78) being transmitted.

Note: On keyboards featuring "even parity," the no. 8 code element is also inverted in a manner similar to that described above for the no. 5 code element.

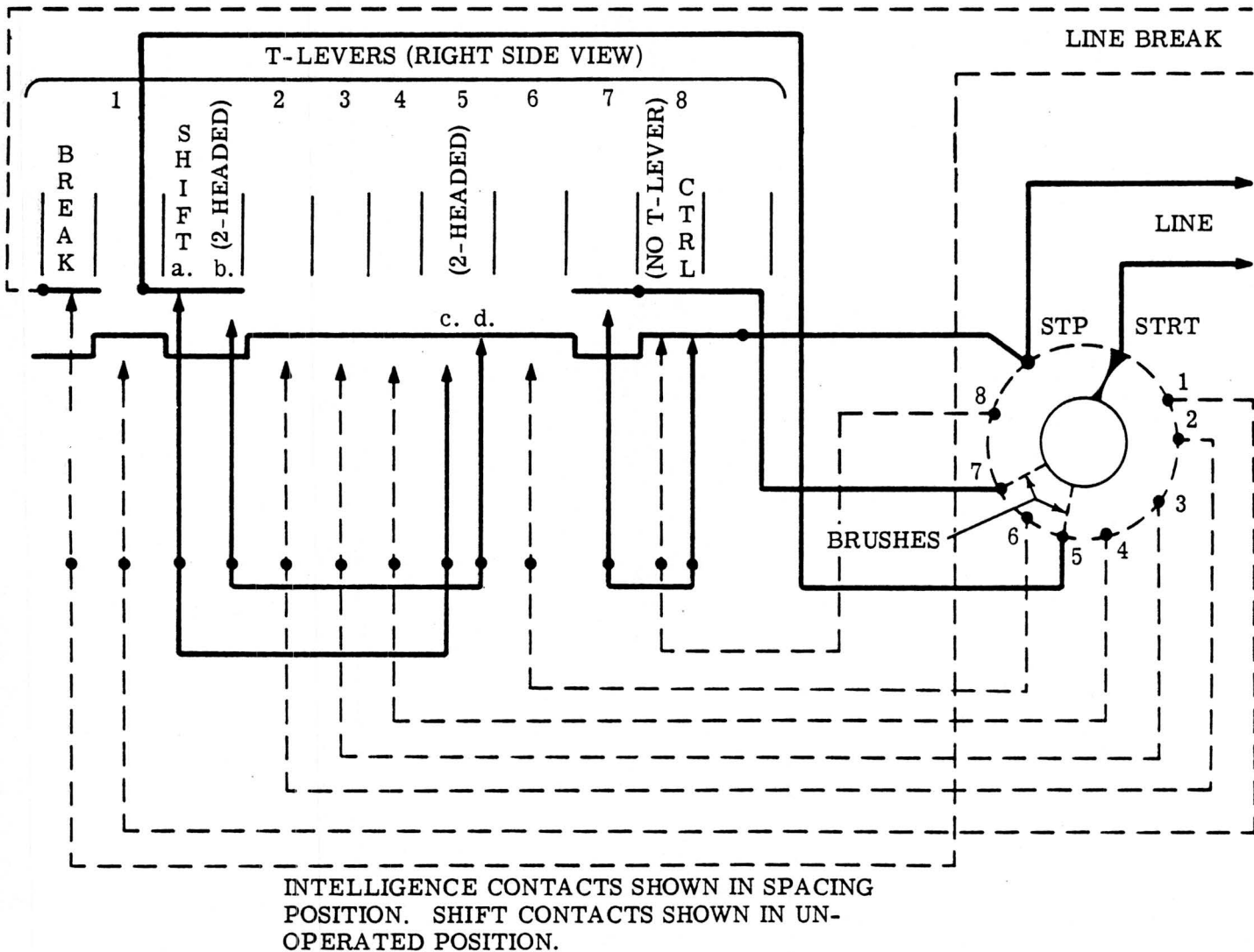

Figure 7 - Signal Wiring - 33 Keyboard (Without "Even Parity")

2.29 The CTRL key converts the no. 7 code element from marking to spacing on all 33 keyboards. For example, if the "E" key alone is depressed, the "E" code combination (1-3---78) is set up in the keyboard contacts and subsequently transmitted. (The path of the current for the marking no. 7 code element is through the stop distributor disc segment, the common terminal, the closed control contact, the closed no. 7 contact, the no. 7 distributor disc segment, the brushes, the inner distributor disc, and the start distributor disc segment.) If the "E" key is held down with the CTRL key, the same condition as before is set up in the contacts, except that

the control T-lever opens the control contact and thus breaks the signal circuit. This results in the no. 7 code element being spacing and the code combination for "WRU" (1-3----8) being transmitted.

Note: On keyboards featuring "even parity," the CTRL key inverts no. 8 code element and converts no. 6 code element from marking to spacing, in addition to converting no. 7 code element from marking to spacing. If no. 8 code element is normally marking, the CTRL key makes it spacing. If no. 8 code element is normally spacing, the CTRL key makes it marking.

32 AND 33 KEYBOARD

LUBRICATION

CONTENTS	PAGE
1. GENERAL .....	1
2. BASIC UNIT .....	2
Codebar mechanism .....	4
Contact block .....	3
HERE IS, BREAK, and REPT keylevers .....	3
Keyboard .....	2
Keylevers .....	2
Latchlever hooks .....	3
Reset bail .....	4
Spacebar .....	2
Universal lever .....	4

<u>Operating Speed</u> (Words per Minute)	<u>Lubrication</u> <u>Interval</u>
60 or 66	1000 hr* or 1 yr**
100	500 hr* or 6 mo**

\*Station Set operating hours.  
 \*\*Whichever comes first.

1.05 The textual instructions that accompany each line drawing consist of abbreviated directions, specific lubrication points, and parts affected. The meanings of the abbreviated directions (symbols) are given below:

<u>Symbol</u>	<u>Meaning</u>
D	Keep dry - no lubricant permitted
OL	Oil liberally (3 or more drops)
OS	Oil sparingly (1 or 2 drops only)
OSD	Oil sparingly or leave dry**
OSL	Oil sparingly or liberally

\*\*Applies to all areas not contacted by other parts.

1.06 References to "left," "right," "front," or "rear," etc consider the keyboard to be viewed from a position where the spacebar faces up and the contact mechanism is located to the viewer's right.

**CAUTION: DO NOT USE ALCOHOL, MINERAL SPIRITS, OR OTHER SOLVENTS TO CLEAN PLASTIC PARTS OR PARTS WITH PROTECTIVE - DECORATIVE FINISHES. NORMALLY, A SOFT, DRY CLOTH SHOULD BE USED TO REMOVE DUST, OIL, GREASE, OR OTHERWISE CLEAN PARTS OR SUBASSEMBLIES. IF NECESSARY, A SOFT CLOTH DAMPENED WITH SOAP OR MILD DETERGENT MAY BE USED. AFTERWARDS, RINSE PART OR SUBASSEMBLY WITH A SOFT, DAMP CLOTH AND BUFF WITH A SOFT, DRY CLOTH.**

1. GENERAL

1.01 This section is issued to provide instructions for lubricating the 32 and 33 keyboard and to present the lubricating instructions as a separate section.

1.02 The general lubrication areas are illustrated by a photograph. The specific points to receive lubricant are indicated on line drawings with appropriate textual instructions. The line drawings and textual instructions follow the photograph and are keyed to the photograph by paragraph numbers.

1.03 Thoroughly lubricate the keyboard, but avoid over lubrication that might permit the lubricant to drip or be thrown onto adjacent parts. Use KS7470 Oil.

1.04 Lubricate the keyboard before placing it into service or prior to storage. After a short period of service, relubricate it to make sure no areas have been missed. Thereafter, lubricate the keyboard at regular intervals as indicated:

2. BASIC UNIT

2.01 Keyboard

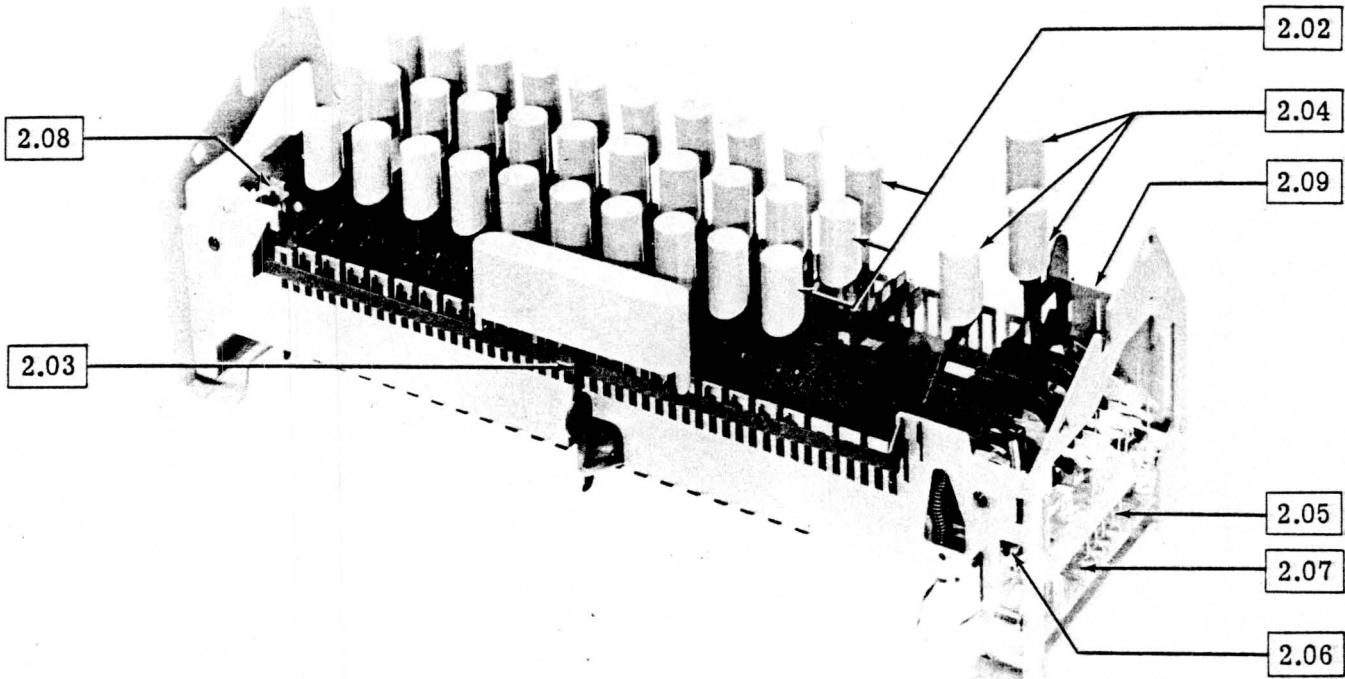

(KEYBOARD - COVER REMOVED - RIGHT FRONT VIEW)

2.02 Keylevers

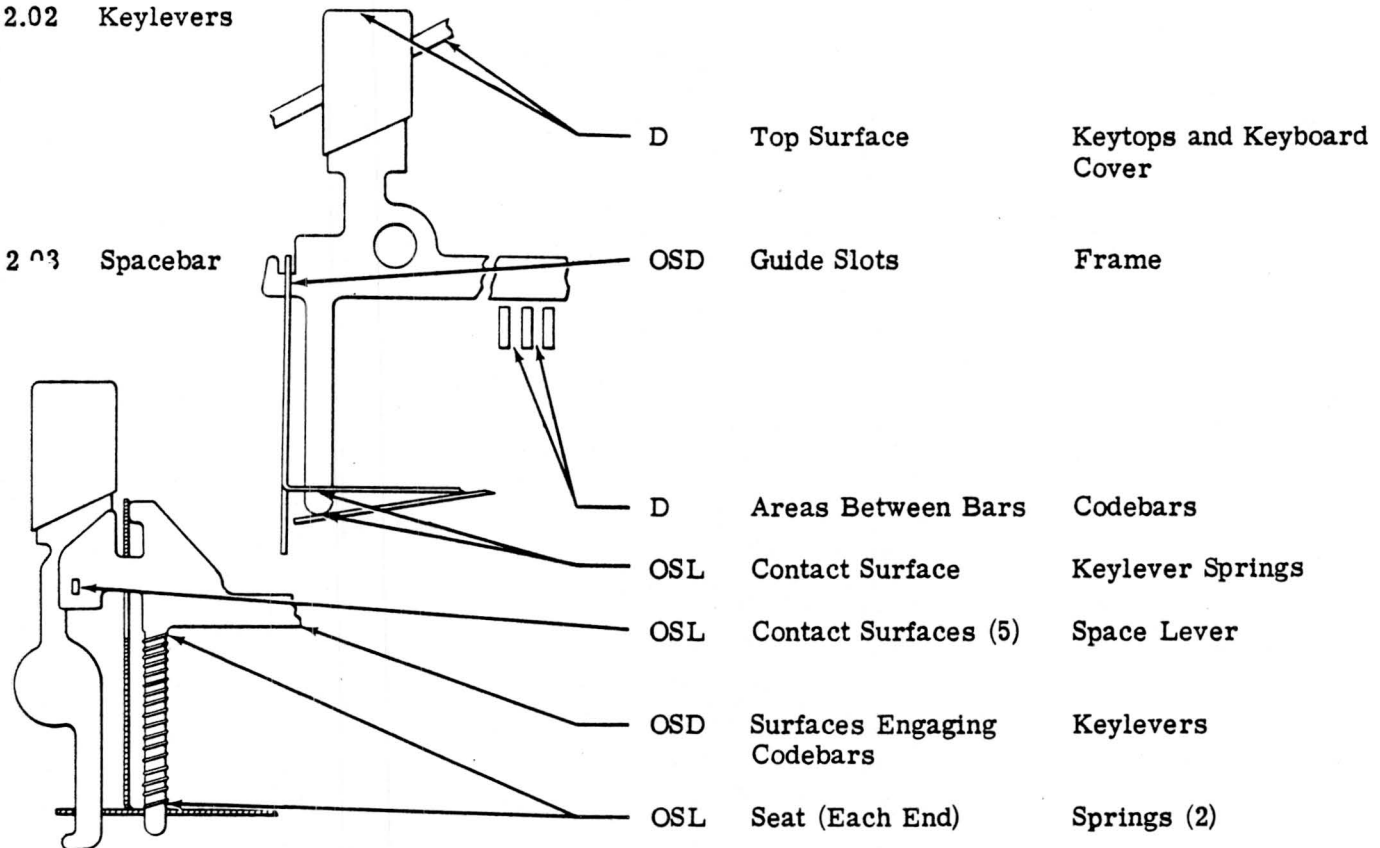

(RIGHT SIDE VIEW)

2.04 HERE IS, BREAK, and REPT Keylevers

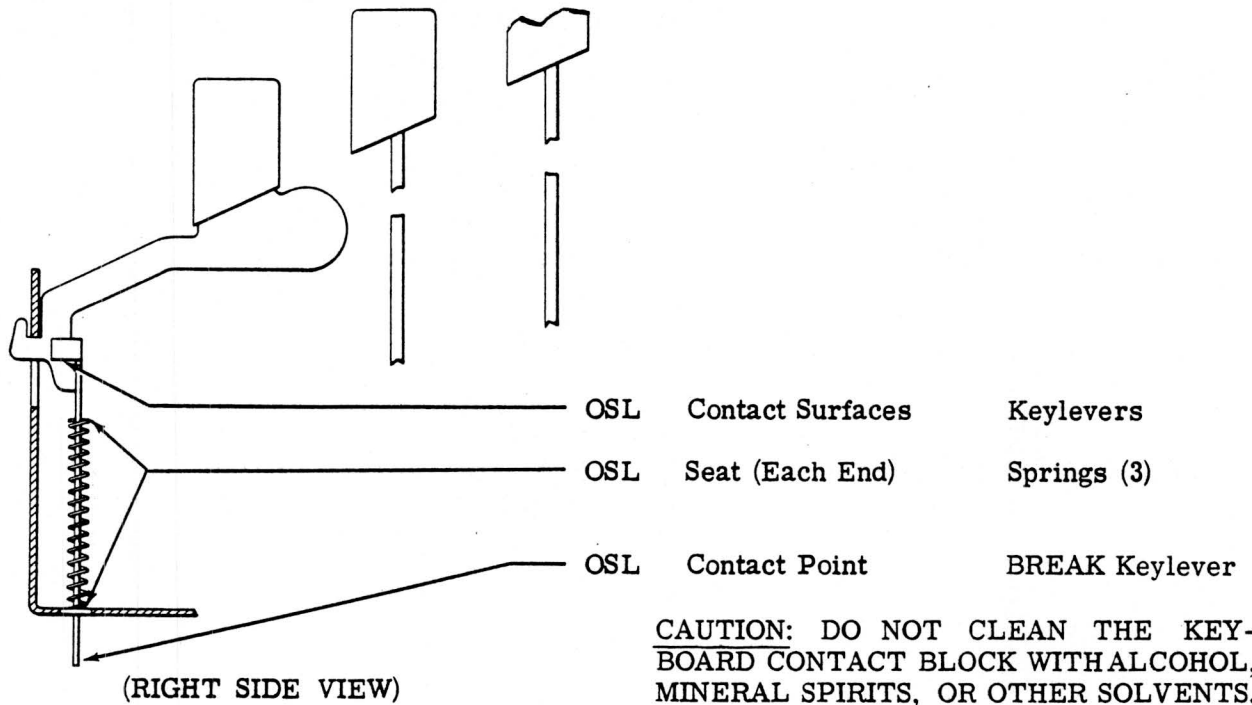

2.05 Contact Block

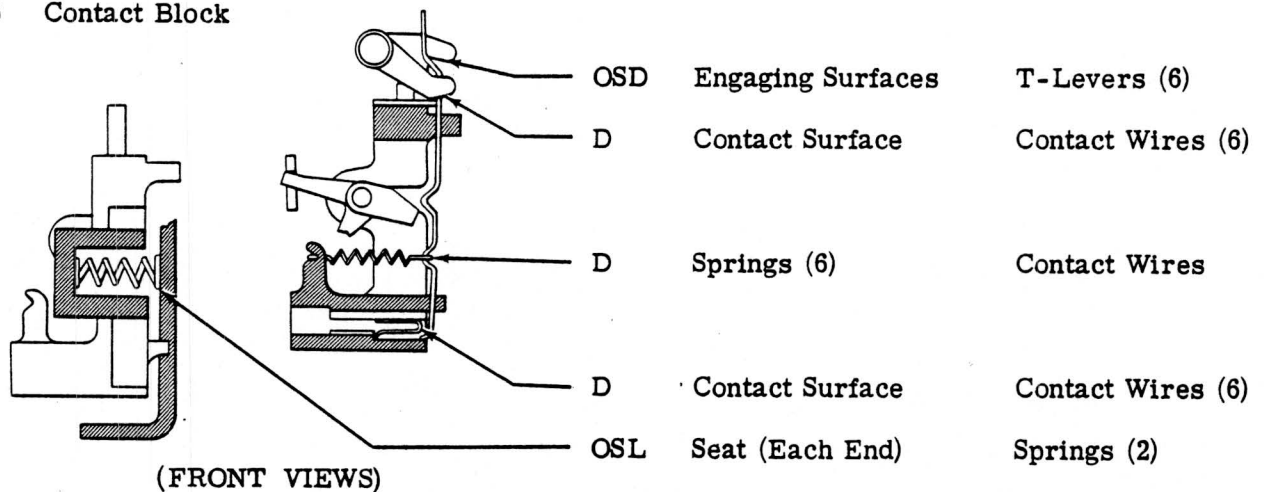

2.06 Latchlever Hooks

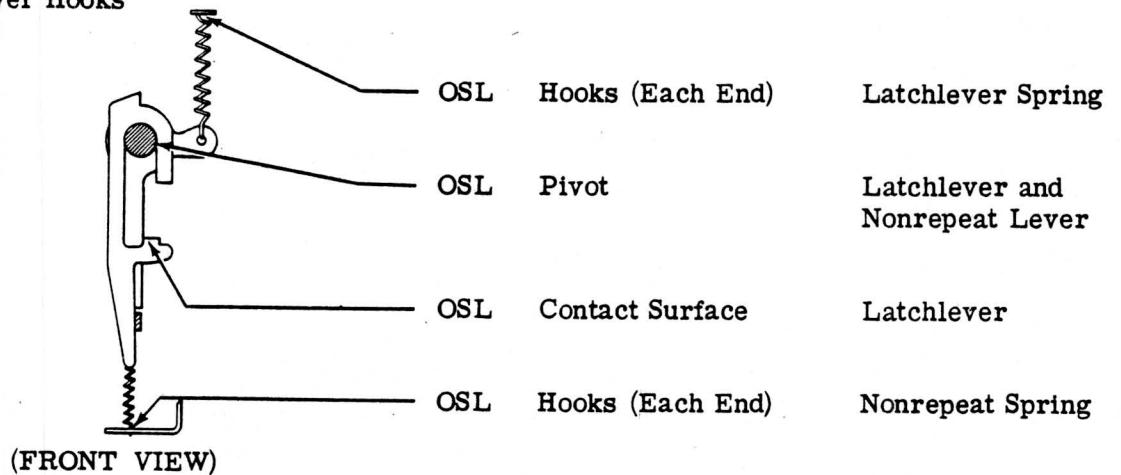

2.07 Reset Bail

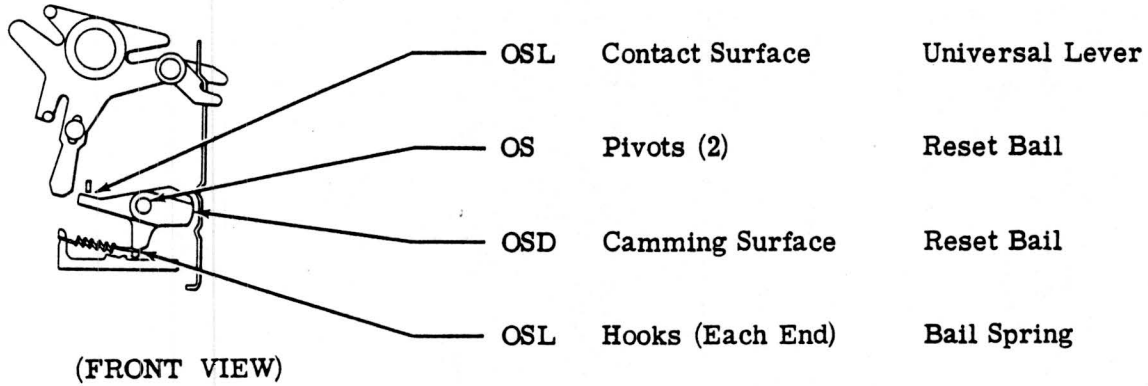

2.08 Codebar Mechanism

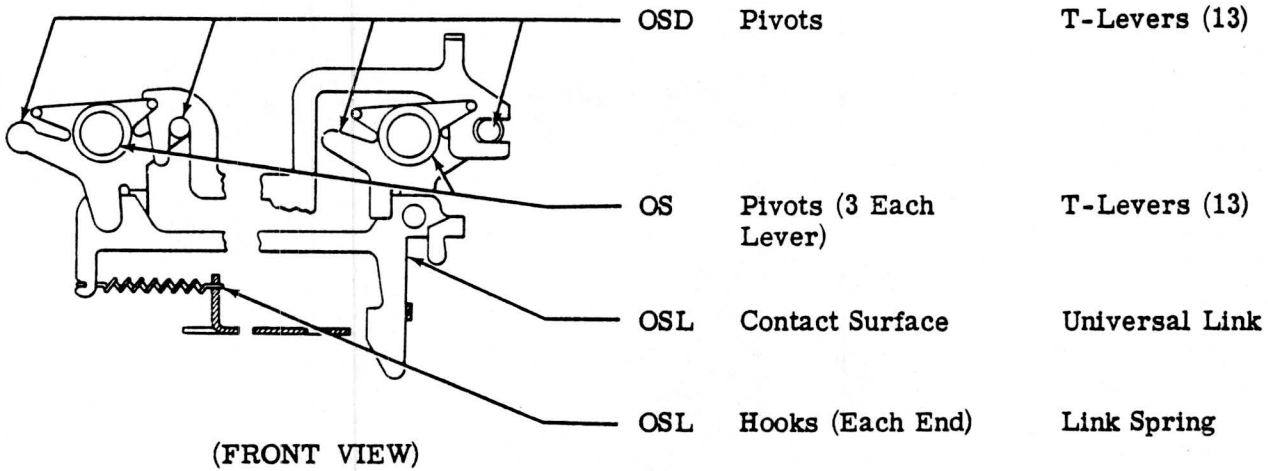

2.09 Universal Lever

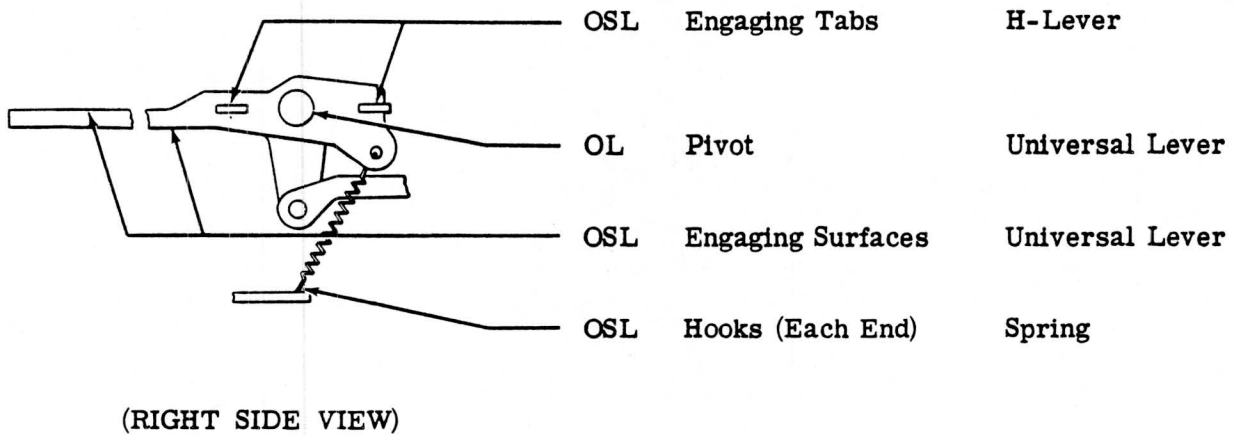

32 AND 33 KEYBOARD  
DISASSEMBLY AND REASSEMBLY

CONTENTS	PAGE
1. GENERAL . . . . .	1
2. DISASSEMBLY AND REASSEMBLY . .	1

1. GENERAL

1.01 This section is issued to provide disassembly and reassembly instructions for the 32 and 33 keyboard and to present the instructions as a separate section.

1.02 References to "left," "right," "front," "rear," etc consider the keyboard to be viewed from a position where the spacebar faces up and the contact mechanism is located to the viewer's right.

1.03 The disassembly procedure given in this section will break the keyboard down into its major assemblies and mechanisms. If further disassembly is required, refer to the appropriate illustrated parts section which shows detailed arrangements of parts. Where it will help in determining their location, the numbers of the parts are given in the instructions.

2. DISASSEMBLY AND REASSEMBLY

**CAUTION:** BEFORE BEGINNING DISASSEMBLY, REMOVE CONNECTORS FROM EXTERNAL RECEPTACLES (POWER SOURCE, DATA SET, ETC).

2.01 General:

(a) When self-tapping screws are used to mount mechanisms onto castings, do not remove the self-tapping screws. Merely loosen them enough to remove the mechanisms unless specifically instructed otherwise.

(b) Retaining rings are made of spring steel and have a tendency to release suddenly. To avoid loss of these rings when removing them, proceed as follows:

(1) Hold retaining ring to prevent its rotating.

(2) Place blade of screwdriver in one of ring's slots and rotate screwdriver to increase diameter.

(3) Ring will come off easily in fingers without flying.

2.02 To remove keyboard and call control unit, proceed as follows:

Note: Reference Figures 1 and 2.

(1) Remove the keyboard plug from its receptacle on the call control unit.

(2) Remove four TP121551 mounting screws and remove call control unit.

(3) Disengage keyboard cable from TP182531 cable clips on subbase.

(4) Insert screwdriver in slot in TP180977 H-plate and push to left against pressure of spring until H-plate is disengaged from universal lever. Remove H-plate.

Note: If the typing unit has been removed from its seat on the subbase, the H-plate will already have been removed.

(5) Loosen two TP180798 keyboard mounting screws. Slide keyboard assembly to rear and lift it from subbase.

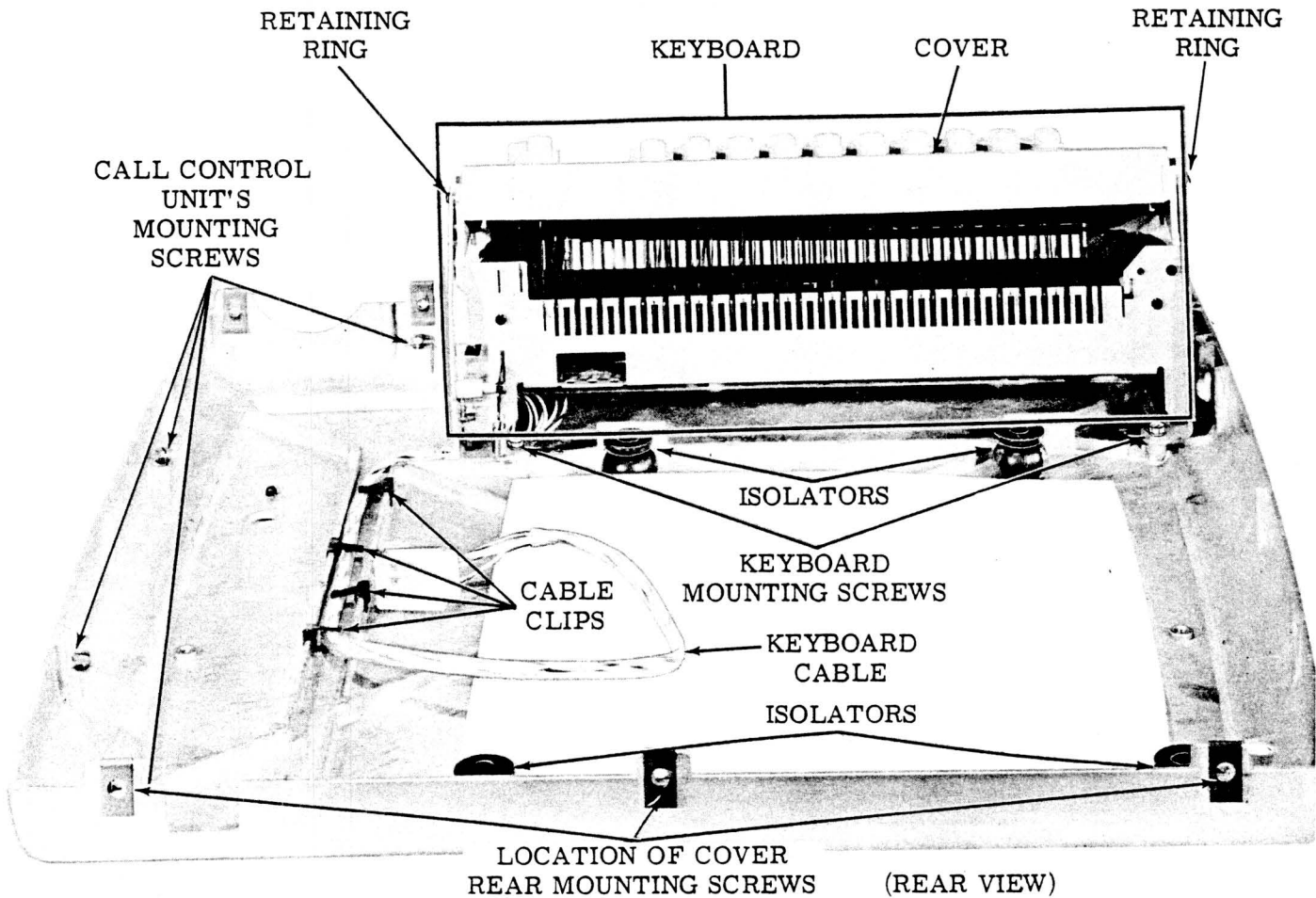

Figure 1 - Subbase With Keyboard

- (6) To replace keyboard, reverse procedure used to remove it.

**CAUTION:** MAKE SURE THAT PLUG IS MATED WITH SIMILARLY DESIGNATED RECEPTACLE.

- 2.03 To remove keyboard cover, proceed as follows:

Note: Reference Figure 1.

- (1) Remove TP119652 retaining ring from each side of keyboard cover.
- (2) Disengage cover from right and left side bracket.
- (3) Lift cover off keys.

- (4) To replace keyboard cover, reverse procedure used to remove it.

- 2.04 To remove miscellaneous parts, proceed as follows:

- (1) To remove any keylever depress front end of TP180086 universal lever. Depress keylever, disengage it from front or rear guide slot, and lift it out of keyboard frame.

Note: Certain levers have compression springs on their lower stems so that the springs may be properly replaced during reassembly.

- (2) To remove spacebar mechanism, remove spacebar with attached keylever. Bow TP180056 space lever and disengage it from

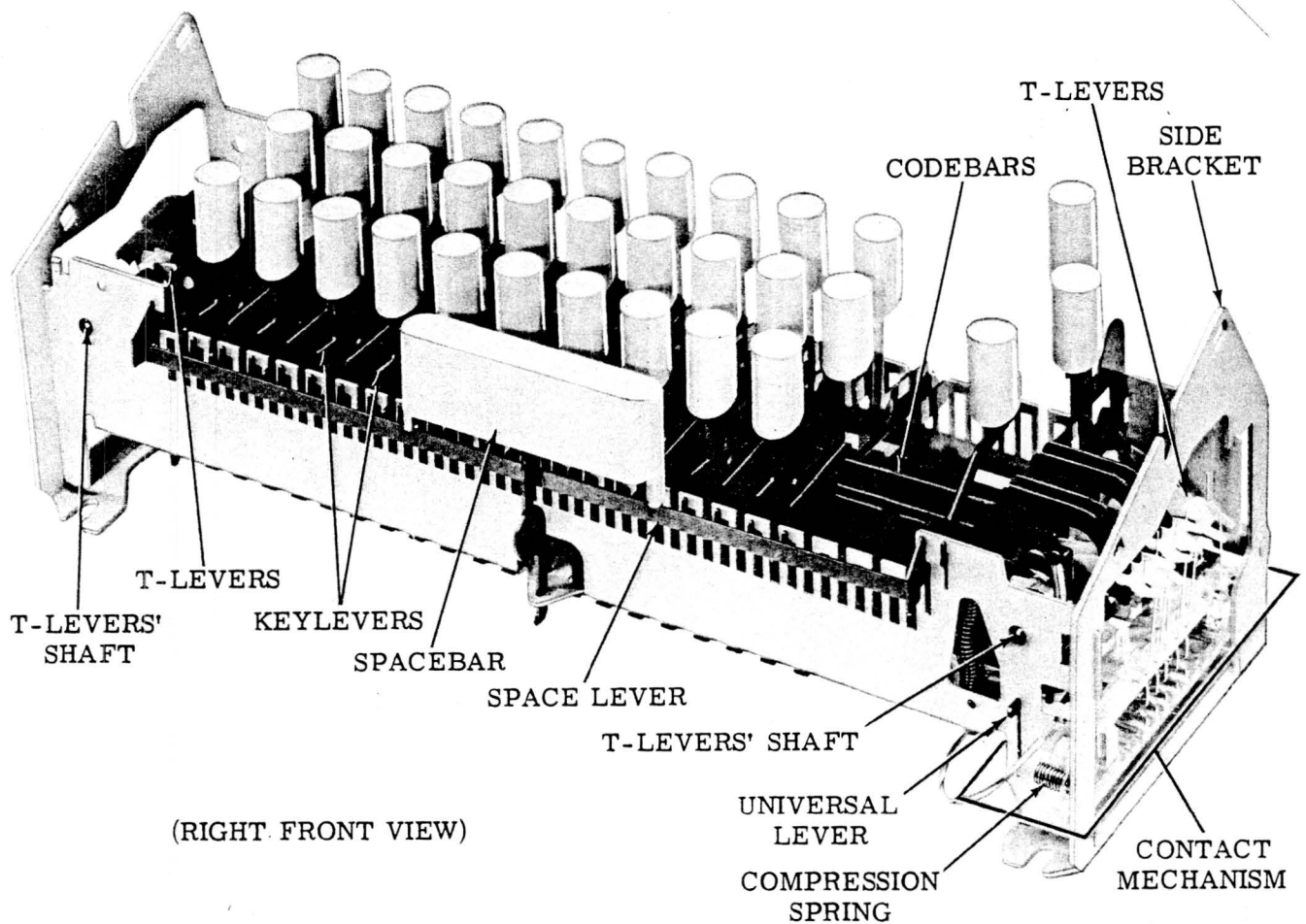

(RIGHT FRONT VIEW)

Figure 2 - Keyboard (Cover Removed)

two TP180055 space keylevers. Disengage space keylevers from guide slots and remove them from frame.

Note: Note position of compression springs on keylever's lower stems so that they can be properly replaced during reassembly.

(3) Codebar may be removed after all keylevers are removed. Disengage bars from T-levers and lift out of keyboard frame.

(4) To remove keyboard contact mechanism, remove right side bracket by snapping it off frame. Remove contact mechanism.

Note: Note position of TP180031 compression springs so that they may be properly replaced during reassembly.

(5) To remove the two T-lever shafts, spread frame and lift out. To remove T-levers, remove TP119653 retaining rings and slide levers off their shafts.

(6) To replace miscellaneous parts, reverse procedure used to remove them.

32 AND 33 TYPING UNIT  
 PRINCIPLES OF OPERATION

CONTENTS	PAGE	CONTENTS	PAGE
1. GENERAL . . . . .	1	C. Power . . . . .	19
TELETYPEWRITER CODE . . . . .	2	D. Rotary Positioning . . . . .	19
A. 32 Typing Units . . . . .	2	E. Vertical Positioning . . . . .	24
B. 33 Typing Units . . . . .	2	F. Printing Mechanism . . . . .	26
GENERAL OPERATION . . . . .	5	G. Ribbon Mechanism . . . . .	28
A. Power Distribution . . . . .	5	H. Example . . . . .	29
B. Power Transmission . . . . .	5	SPACING . . . . .	31
C. Reception and Printing . . . . .	5	A. General . . . . .	31
D. Function Mechanism . . . . .	5	B. With Printing . . . . .	31
E. Spacing Mechanism . . . . .	5	C. Space Suppression . . . . .	31
F. Paper Feed Mechanism (Friction Feed Typing Units) . . .	5	D. Space Function . . . . .	31
G. Form-Out Mechanism (Sprocket Feed Typing Units) . . .	6	E. Carriage Return . . . . .	32
2. DETAILED PRINCIPLES OF OPERATION . . . . .	6	PAPER OR FORM FEEDING . . . . .	33
POWER DISTRIBUTION . . . . .	6	A. Friction Feed Typing Units . . .	33
A. Motor . . . . .	6	B. Sprocket Feed Typing Units . . .	35
B. Distribution . . . . .	6	END-OF-LINE BELL . . . . .	38
C. Clutches . . . . .	6	AUTOMATIC CARRIAGE RETURN- LINE FEED . . . . .	38
TRANSMISSION . . . . .	6	ANSWER-BACK MECHANISM . . . . .	39
A. General . . . . .	6	A. General . . . . .	39
B. Distributor Mechanism . . . . .	10	B. Drum . . . . .	41
RECEPTION AND CONVERSION . . .	13	C. Remote Actuation—Function Mechanism . . . . .	41
A. Selector Mechanism . . . . .	13	D. Local Actuation—HERE-IS Key . .	42
B. Range Finder . . . . .	16	E. First Character Suppression . . .	42
C. Codebar Mechanism . . . . .	16	F. Answer-Back Suppression on Transmission . . . . .	42
FUNCTION MECHANISM . . . . .	17	G. Length of Answer-Back Sequence . . . . .	43
PRINTING . . . . .	19	1. GENERAL	
A. General . . . . .	19	1.01 This section is issued to provide prin- ciples of operation for the 32 and 33 typing unit and to present the principles as a	
B. Typewheel . . . . .	19		

separate section. It describes the code used by the typing unit to transmit and receive messages, outlines in general terms the overall operation, and explains in detail the operation of the components that make up the typing unit.

1.02 References to "left," "right," "front," or "rear," etc, consider the typing unit to be viewed from a position where the carriage faces up and the selector mechanism is located to the viewer's left. In the illustrations, fixed pivots are solid black, and floating pivots—those mounted on parts that move, are cross-hatched.

## TELETYPEWRITER CODE

1.03 Teletypewriters transmit and receive messages by means of a binary permutation code (Figures 1 and 2). The characters making up the messages (letters, numerals, symbols, functions, etc) are represented by pre-arranged combinations of binary intelligence elements (also referred to as levels, or bits), each of which may be in one of two states—on or off. Depending on whether a 5- or 8-level code is employed, each combination consists of five, six, seven, or eight intelligence elements. The total number of permutations available in a given code is equal to 2 to the  $n^{\text{th}}$  power, where "n" is the number of intelligence elements. For example, in a 6-level code, there are 2 to the 6<sup>th</sup> power, or 64, permutations.

1.04 In the various stages of a communication system using teletypewriter equipment, the above code may occur in a number of different forms, including parallel or sequential electrical pulses, mechanical positions of parts, code holes in paper tape, and tone frequencies. For transmission purposes, it is placed in an electrical form referred to as a start-stop signaling code, or simply a teletypewriter code (Figures 1 and 2). The intelligence elements are applied sequentially to a signal line as current or no-current time intervals. Intervals during which current flows in the signal line are referred to as "marking" elements, and intervals during which no current flows as "spacing" elements. To insure synchronization between the transmitting and receiving equipment, a start element, which is always "spacing," is added at the beginning of each combination of intelligence elements, and a stop element, which is always "marking," is added at the end.

1.05 In different signaling codes, the length of the stop element may vary. For example, in the teletypewriter code illustrated in Figure 1, the length of the stop element is 1.5 times the other elements. Thus, the transmission of a character requires 7.5 units of time. It is therefore said to have a 7.5-unit transmission pattern.

### A. 32 Typing Units

1.06 The teletypewriter code accommodated by the 32 typing unit is illustrated in Figure 1. Since it has five intelligence elements and its stop element is 1.5 units of time, it is a 5-level code with a 7.5-unit transmission pattern. It has 2 to the 5<sup>th</sup> power, or 32 available permutations.

1.07 To accommodate more than 32 characters, a letters-figures shift is designed into the typing unit. This is similar to the lower and upper case of a typewriter and permits each code combination, excluding the two used to shift the equipment, to represent two characters.

1.08 A character arrangement is shown on the chart in Figure 1. The black circles represent marking elements; the blank squares represent spacing elements. When the "letters" code combination (12345) is transmitted, it conditions all typing units connected to the circuit to print, at the receipt of all following code combinations, the characters in the letters (lower case) line on the chart. Similarly, when the "figures" code combination (12-45) is transmitted, it conditions the typing units to print the characters or perform the functions in the figures (upper case) line on the chart.

### B. 33 Typing Units

1.09 The American Standard Code for Information Interchange (ASCII) accommodated by the 33 typing unit is illustrated in Figure 2. Since it has eight intelligence elements and its stop element is 2 units of time, it is an 8-level code with an 11-unit transmission pattern. However, at the present it utilizes only the first seven intelligence elements, the eighth being used to provide an error detection feature called "even parity." When "even parity" is not provided, the eighth intelligence element is always transmitted as a marking element. Thus, it has 2 to the 7<sup>th</sup> power, or 128, available permutations. Of these combinations, 64

TRANSMISSION SEQUENCE

5-LEVEL		S																			START ALWAYS SPACING		
INTELLIGENCE ELEMENTS	ON																					NO.1 MARKING OR SPACING	
	OFF																						
	ON																					NO.2 MARKING OR SPACING	
	OFF																						
	ON																					NO.3 MARKING OR SPACING	
	OFF																						
	ON																						NO.4 MARKING OR SPACING
	OFF																						
	ON																						NO.5 MARKING OR SPACING
	OFF																						
																						STOP ALWAYS MARKING	

5-LEVEL BINARY PERMUTATION CODE

FIGURES	-	5/8	7/8	3	1/4	&	8	'	1/2	3/4	•	7/8	9	0	1	4	BELL	5	7	3/8	2	/	6	"	BLANK	LETTERS	FIGURES	SPACE	CARRIAGE RETURN	LINE FEED	
LETTERS	A	B	C	D	E	F	G	H	I	J	K	L	M	N	O	P	Q	R	S	T	U	V	W	X	Y	Z					
1	●	●	●	●	●				●	●					●		●			●	●	●	●	●	●	●	●	●	●	●	●
2	●		●				●		●	●	●	●				●	●	●			●	●	●				●	●			●
3			●			●		●	●		●	●	●		●	●		●		●	●	●	●	●			●	●	●		
4		●	●	●		●	●		●	●		●	●	●			●					●		●			●	●			●
5		●					●	●				●	●	●	●					●		●	●	●	●	●	●	●	●		

CHARACTER ARRANGEMENTS

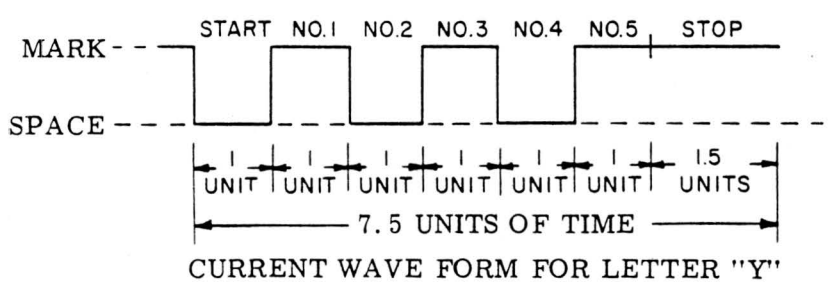
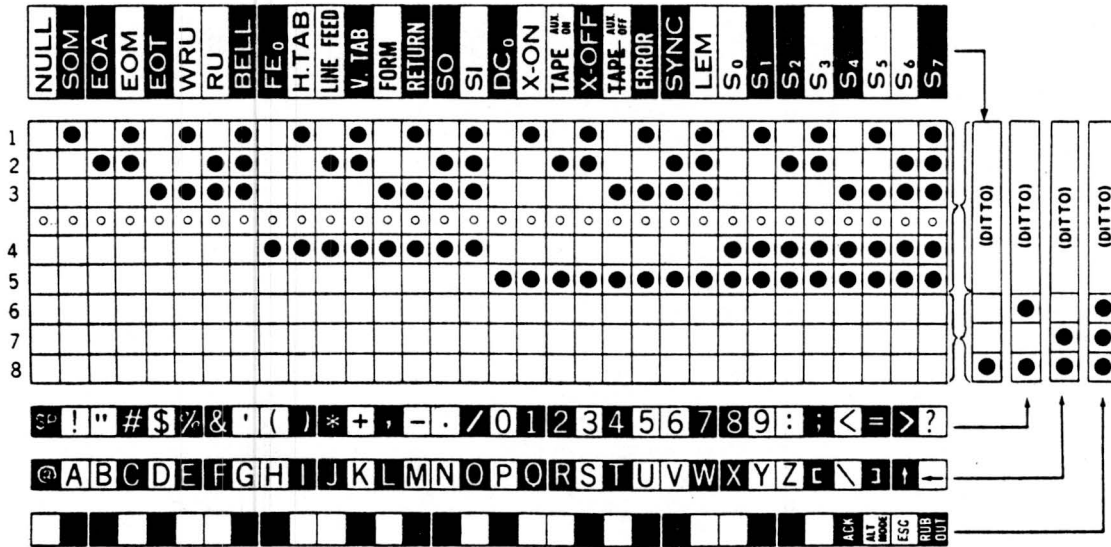
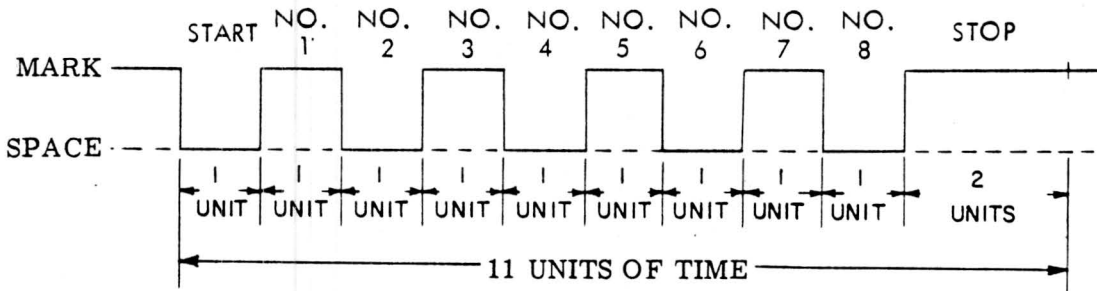

Figure 1 - Teletypewriter Code (5-Level)

X



CHARACTER ARRANGEMENT (ASCII CODE)



CURRENT WAVE FORM FOR LETTER "U" (WITH "EVEN PARITY")

Figure 2 - Teletypewriter Code (8-Level)

are assigned to printing characters. The rest are devoted to control (nonprinting) characters, or are unassigned.

Note: "Even parity" is an error detection feature which provides for adding a pulse whenever the number of marking pulses in a code combination is odd.

1.10 The character arrangement for the ASCII code is shown on the chart in Figure 2. The black circles represent marking elements,

the blank squares spacing elements. The main block gives the arrangements of elements 1 through 5. The four smaller blocks at the right give the arrangements of elements 6 and 7 for the four rows of characters as indicated by the arrows. When "even parity" is provided; characters and functions which have white backgrounds in the character arrangement chart have the eighth intelligence element spacing—dark backgrounds have the eighth intelligence element marking. For keyboard transmission, two SHIFT keys and a CTRL key are used as covered in the appropriate keyboard section.

## GENERAL OPERATION (Figures 3, 4 and 5)

1.11 Figure 3 is a pictorial schematic of a basic typing unit's operation. Figures 4 and 5 show the sequence of events involved in receiving a character.

### A. Power Distribution

1.12 As shown in the middle portion of Figure 3, ac electrical power is applied to a motor through a motor switch, which may be manually or automatically controlled. The motor converts the electrical power to rotary motion, which is transferred by intermediate drive parts to a distributor shaft. The latter drives a main shaft and, through a clutch, provides motion to a distributor mechanism. The main shaft, through various clutches, distributes motion to a selector mechanism, a codebar mechanism, a function mechanism, a spacing mechanism, a carriage, and, in the case of sprocket feed typing units, a platen.

### B. Transmission

1.13 The upper portion of the diagram (Figure 3) illustrates transmission, which is effected by an operator depressing the keys of a keyboard. Assume that the D key is manually depressed. A codebar mechanism converts this selective action to mechanical positions corresponding to the code combinations representing the letter D. These positions, in turn, set up the code combination in a set of keyboard contacts, and, by parallel output, the code combination is transmitted to the distributor. The distributor then translates the parallel output from the keyboard contacts into a corresponding start-stop signaling code combination and applies it to the transmission facilities, which carry it to distant stations. Since a local selector magnet driver is connected to the transmission facilities, it also receives the signals.

### C. Reception and Printing

1.14 The lower portion of the diagram (Figure 3) illustrates reception and printing. Assume that the start-stop signaling code combination representing the letter D, which may have been originated either remotely or by the local keyboard, is received from the transmission facilities by the selector magnet driver. The driver converts it to a form suitable to operate the selector mechanism. The selector

then translates it to mechanical positions which are transferred to the codebar mechanism.

1.15 Under the control of the codebar mechanism, rotary and vertical positioning mechanisms on the carriage position a type-wheel so as to select the letter D embossed on its surface. A printing mechanism, by means of a print hammer, drives the typewheel against an inked ribbon and the paper to print the character. A ribbon mechanism feeds the ribbon and reverses its direction of feed when a spool is depleted.

### D. Function Mechanism

1.16 Controlled by the codebar mechanism, a function mechanism enables the typing unit to perform functions supplementary to printing. The standard functions consist of "space," "carriage return," "line feed," "blank," "bell," and, in the case of 32 typing units, "letters" and "figures." In response to the reception of "letters" or "figures" code combination, the function mechanism conditions the codebar mechanism to cause printing in the lower or upper case, respectively. It also causes the codebar mechanism to suppress printing on receipt of all functions.

### E. Spacing Mechanism

1.17 A spacing mechanism positions the carriage so that the characters are properly located horizontally on the paper. It spaces the carriage each time printing occurs and when the "space" code combination is received. The function mechanism suppresses spacing on the receipt of all functions except "space." At the receipt of "carriage return" code combination, the function mechanism causes the spacing mechanism to return the carriage to the left margin, so that a new printing line can be started.

### F. Paper Feed Mechanism (Friction Feed Typing Units)

1.18 A paper feed mechanism positions the paper vertically so that the characters are properly located in lines on the paper. At the receipt of the "line feed" code combination, the function mechanism causes the line feed mechanism to raise the paper to the next printing line.

G. Form-Out Mechanism (Sprocket Feed Typing Units)

1.19 A form-out mechanism positions the form vertically so that the characters are properly located in lines on the form. At the receipt of the "line feed" or "form-out" code combination, the main shaft, through a line feed clutch, causes the platen to raise the form to either the next printing line or one form length, depending upon which function ("line feed" or "form-out") is used.

2. DETAILED PRINCIPLES OF OPERATION

POWER DISTRIBUTION

A. Motor

2.01 Rotary mechanical motion for the typing unit is generated by synchronous motors. The motors are described in the appropriate description section.

2.02 The motor ordinarily used on 33 typing units has a run winding and a start winding connected in parallel. (See the appropriate schematic wiring diagram.) The start winding is in series with an electrolytic capacitor and the contacts of a current-sensitive start relay. When the motor circuit is closed, the initial surge of current energizes the relay coil, which closes the relay contacts. The magnetic flux produced by the operating and start windings starts the rotor turning. As the rotor accelerates, the current through the windings, capacitor, and relay decreases. When it drops to a predetermined level, the relay coil opens the contacts and removes the start coil from the circuit. Using the operating coil alone, the motor continues to accelerate until it reaches synchronous speed.

2.03 The motor ordinarily used on 32 typing units is similar, but has a run capacitor in addition to a start capacitor.

B. Distribution

2.04 As shown in Figure 6, the rotary motion produced by the motor is transferred through a motor pinion, an intermediate gear pulley, and a motor belt to a distributor gear pulley. The latter drives a main shaft gear and also a distributor clutch, which provides motion for the keyboard and distributor mechanism.

2.05 The main shaft, through various clutches, distributes motion to the various mechanisms on the typing unit (excluding the distributor). A selector clutch provides motion for the selector. A codebar clutch drives the codebar mechanism, and a function clutch furnishes motion to a function rocker shaft, a function stripper bail, a carriage drive bail, and a print-suppression latch.

C. Clutches

2.06 The operation of all clutches is basically the same. A typical clutch is shown in Figure 7.

2.07 A clutch drum is attached to and rotates in unison with a shaft. In their stop position, a trip lever and a latchlever hold a shoe lever, two shoes, a cam disc, and cam sleeve stationary.

2.08 When the trip lever moves away from the shoe lever, the latter, under spring pressure, moves away from a stop-lug on the cam disc. Through two lugs, the shoe lever expands the shoes until they contact the notched inner surface of the drum. The drum causes the shoes to start to rotate, and the shoes, in turn, through a lug on the cam disc, rotate the disc and the attached cam sleeve. The clutch is now engaged, and the cam sleeve rotates in unison with the shaft.

2.09 When the trip lever moves to its stop position, it is struck by the shoe lever. The cam disc continues to rotate until the latchlever seats in its notch, and the shoe lever and stoplug are pinched together by the trip lever and latchlever. A spring holds the shoes together, so they no longer contact the drum. Thus, the clutch is again disengaged as shown in Figure 7.

TRANSMISSION

A. General

2.10 Transmission of messages is accomplished by an operator selectively depressing the keys and spacebar of the keyboard in the same manner as in typing. The downward movement of each key or the spacebar is translated by a codebar mechanism into a mechanical arrangement corresponding to the code combination representing the character on the keytop.

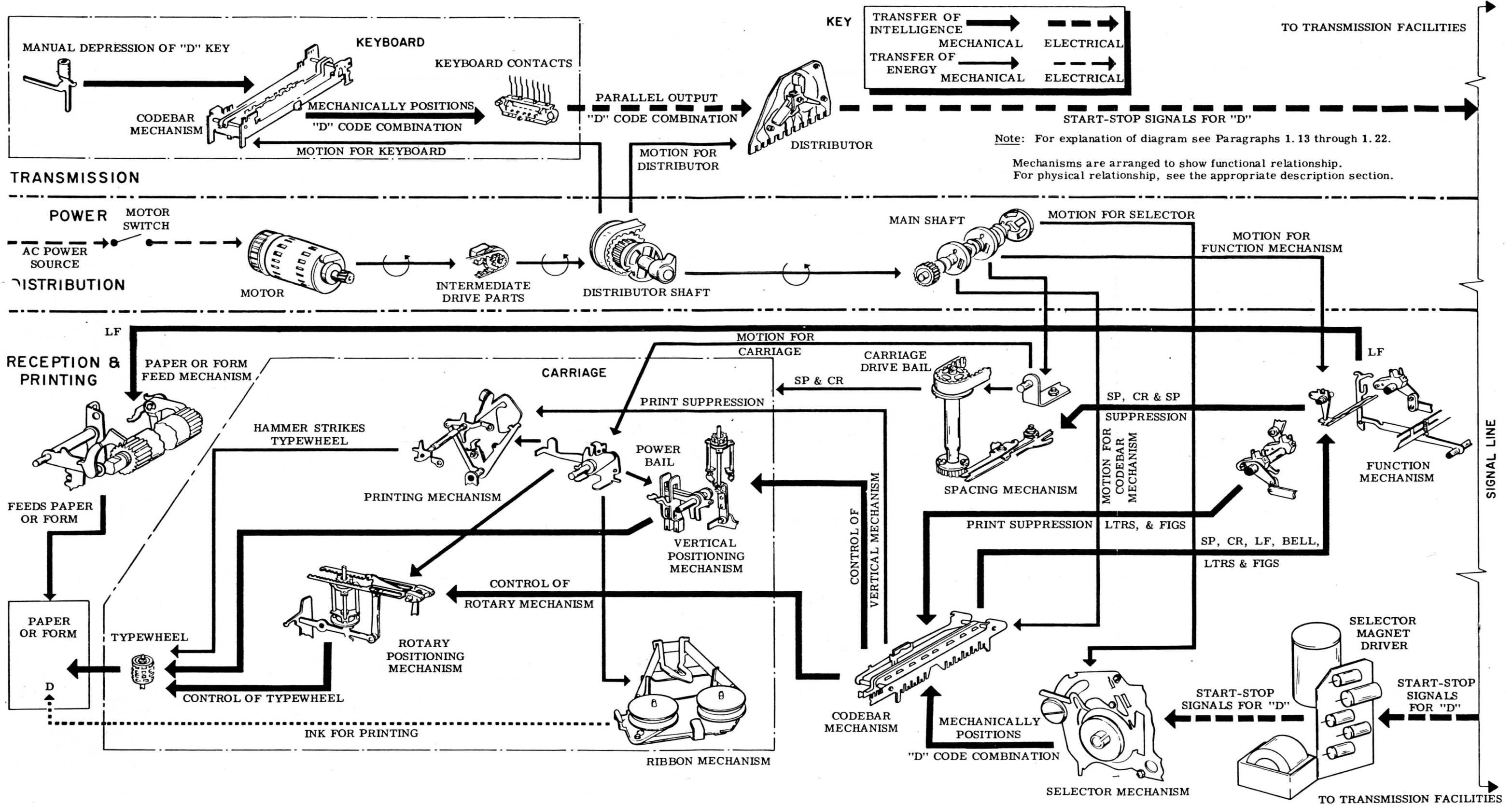

Figure 3 - Schematic Diagram - Typing Unit Operation

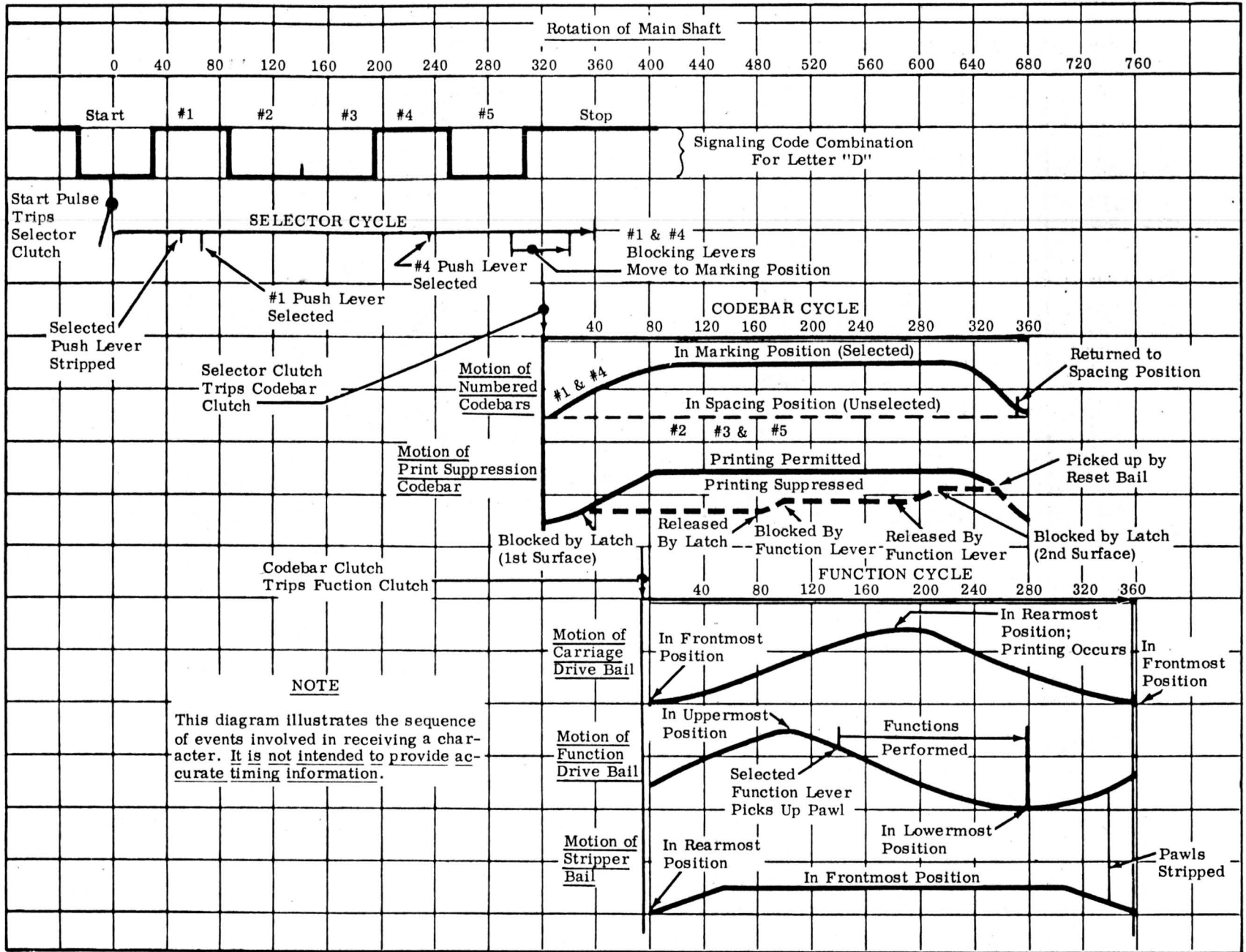
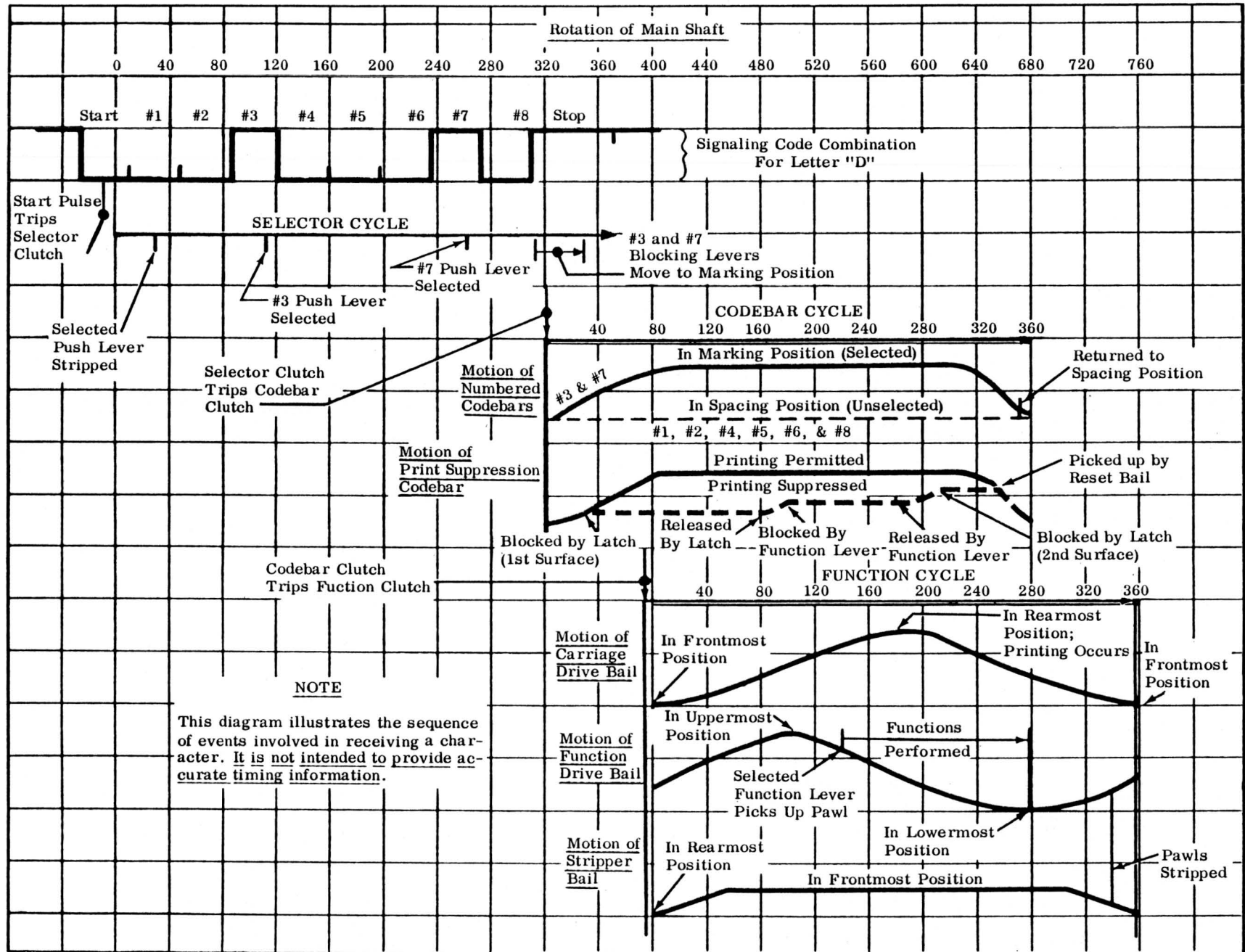

Figure 4 - Sequence Diagram - 32 Typing Unit Operation

Figure 5 — Sequence Diagram - 33 Typing Unit Operation



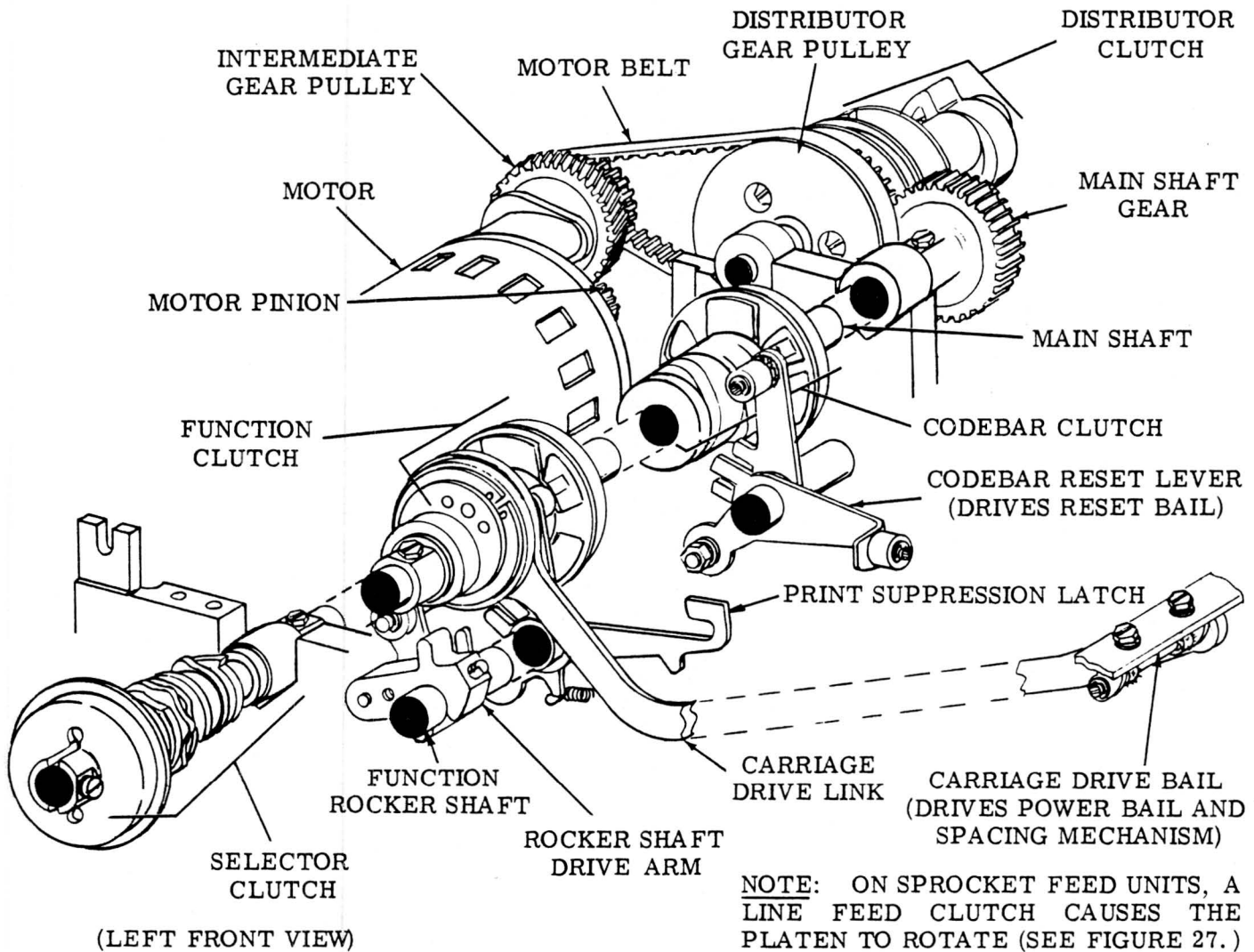

Figure 6 — Power Distribution

The mechanical arrangements set up the code combinations in a set of keyboard contacts, and, by parallel output, the code combinations are transmitted to a distributor mechanism. A universal mechanism trips a distributor clutch, and a distributor mechanism then translates the parallel output from the keyboard contacts into corresponding start-stop signals for application to the transmission facilities.

Note: For a further discussion of transmission principles, see the appropriate keyboard section.

## B. Distributor Mechanism

2.11 The distributor mechanism is illustrated in Figures 8 and 9.

2.12 The distributor mechanism receives the parallel output of the keyboard contacts which have been mechanically arranged into code combinations and converts it to start-stop signals and applies them to the signal line. The mechanism receives rotary motion from a distributor gear pulley attached to the drum of a distributor clutch. The clutch disc is connected to a distributor shaft. A brush holder mounted on the shaft carries two carbon brushes which are electrically connected by a spring and ride on an inner and outer disc, respectively. The discs are part of a printed circuit card that provides facilities for interconnecting the distributor with other apparatus. The outer disc is divided into segments—ten for 33 typing units, seven for 32 typing units. The segments correspond to the elements of the teletypewriter code described in 1.03 through 1.10.

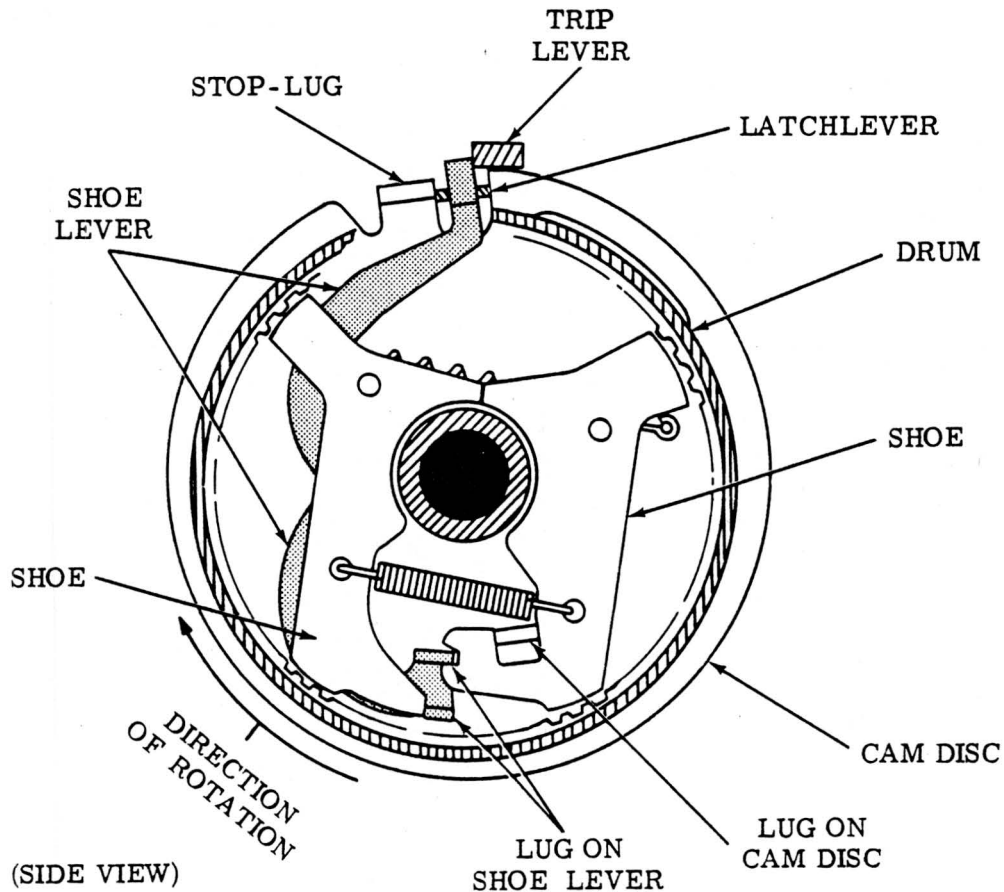

Figure 7 - Clutch

2.13 In the stop position, the distributor clutch is disengaged (latched), and the outer brush rests on the stop segment. When a key-lever is depressed, the proper code combination is set up in the keyboard contacts, and the universal lever moves to its up position. The motion of the transfer lever is conveyed by an H-plate to a distributor trip linkage on the typing unit. The trip linkage pivots a trip bail, which carries a trip lever rearward out of the way of the distributor clutch's shoe lever. The clutch engages and rotates the shaft and brush holder. The outer brush passes over the segments on the outer disc in the following order:

- (a) Start, no. 1 through no. 5, and stop, for 32 typing units.
- (b) Start, no. 1 through no. 8, and stop, for 33 typing units.

2.14 Near the end of the shaft's revolution, a roller on the clutch disc pivots a follower lever which moves the trip bail

and lever frontwards. This motion is transferred through the trip linkage and H-plate to the universal lever, which is moved to its down position, where it is latched. When the clutch completes its revolution, the shoe lever strikes the trip lever, and the clutch disengages.

2.15 The effect of the above operations is to apply a start-stop code combination to the signal line corresponding to the combination set up in the keyboard contacts. This can best be shown by an example. Figure 9 is a simplified schematic of a 32 typing unit distributor.

- (a) In the stop position, the outer brush rests on the stop segment, and the current flows in the signal circuit which is closed. (The signal path is from one side of the line through the start segment, the inner disc, the brushes, the stop segment, the common terminal, and the break contact to the other side of the line.) Thus a marking condition exists. Assume again that

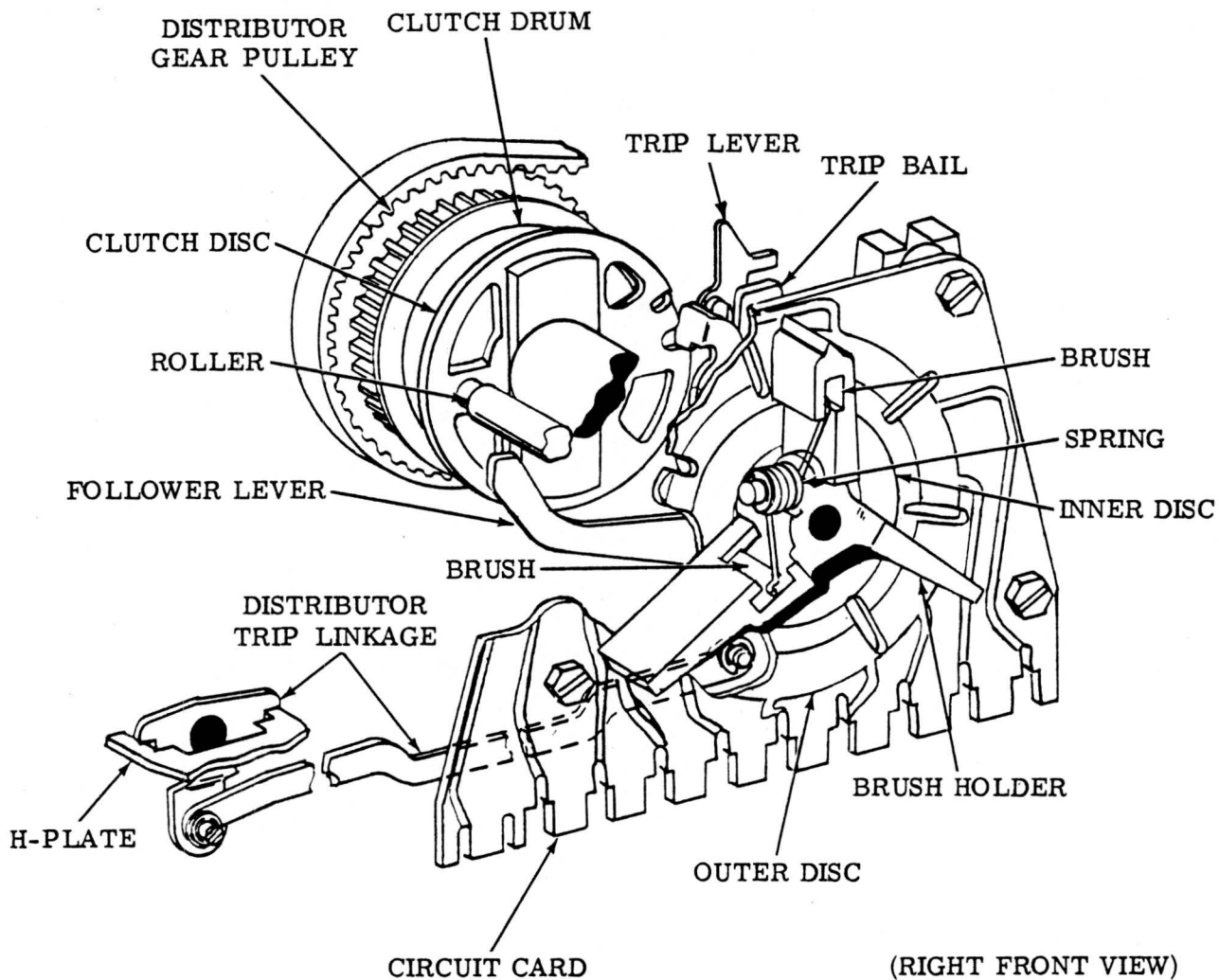

Figure 8 - Distributor Mechanism

the D key is depressed. The (1--4-) code combination is set up in the keyboard contacts.

(b) The distributor clutch is tripped, and the brush holder begins its revolution. While the brush is on the start segment, the circuit is open, no current flows, and a spacing element is transmitted. While it is on the no. 1 segment, the circuit is closed. (The signal path is through the start segment, the inner disc, the brushes, the no. 1 segment, the closed no. 1 contact, the common terminal, and the break contact.) Thus, current flows, and a marking element is transmitted. While the brush is on the no. 2 and no. 3 segments, since

the no. 2 and no. 3 contacts are open, the circuit is broken, no current flows, and spacing elements are transmitted. In a similar manner, a no. 4 marking element and a no. 5 spacing element are transmitted. When the brush reaches the stop segment, the distributor clutch is disengaged, and the line again becomes marking.

2.16 The operation of a 33 typing unit distributor is similar to that explained for the 32 typing unit distributor, except that, as previously noted in 2.12, the outer distributor disc is divided into ten segments, and the distributor generates an 8-level ASCII code (Figure 2).

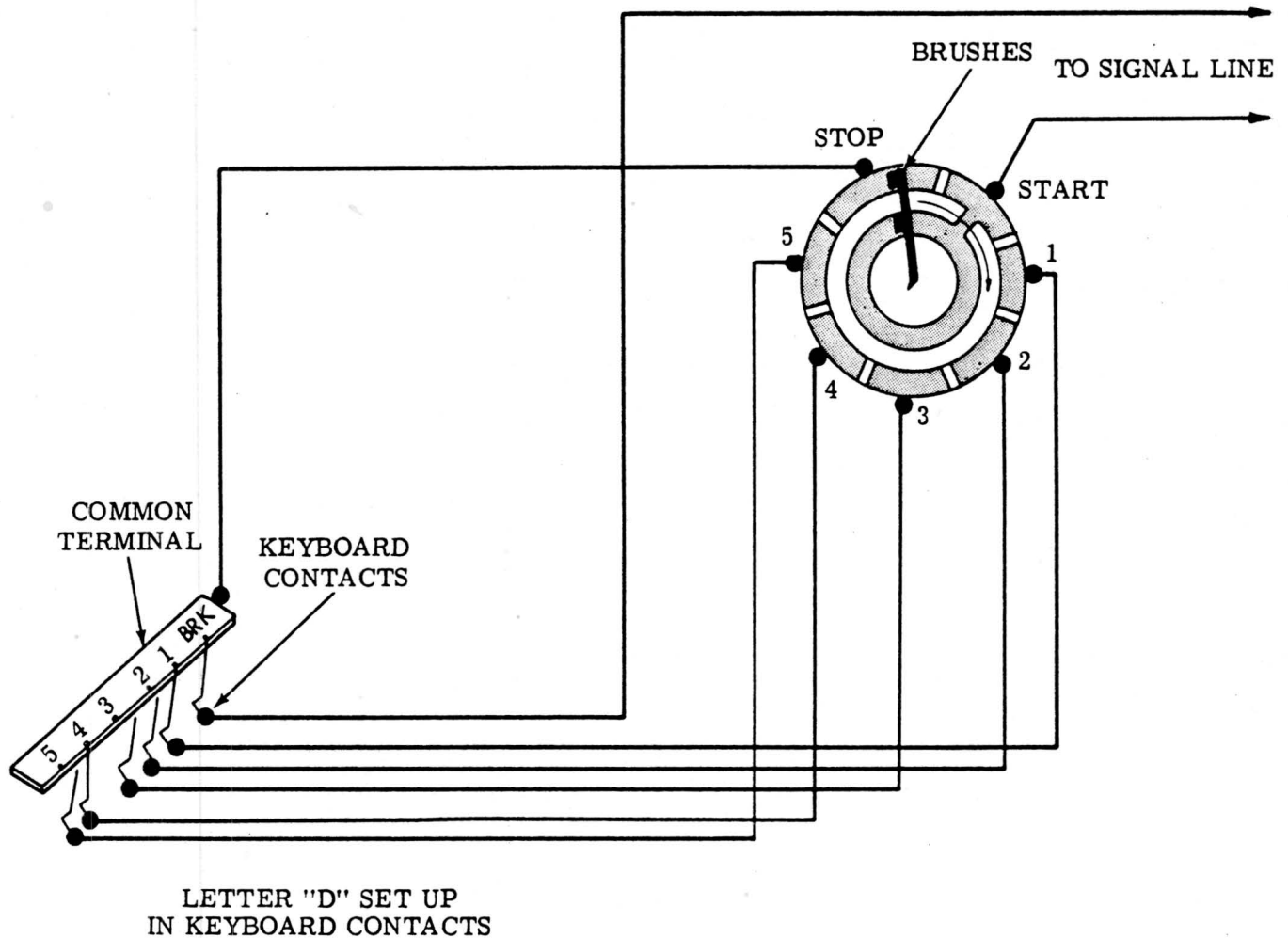

Figure 9 — Signal Wiring - 32 Typing Unit Distributor

## RECEPTION AND CONVERSION

## A. Selector Mechanism

2.17 The selector mechanism receives the signaling code combinations from the selector magnet driver and converts them to corresponding mechanical arrangements that control the codebar mechanism. The selector mechanism is described in the appropriate description section. Figures 10 and 11 illustrate the selector mechanism.

2.18 A magnet coil is wired by two leads to the output of the selector magnet driver. In the stop condition, the output of the selector magnet driver is marking, and the coil is energized and holds the armature against a

magnet core. When a code combination is received, the start pulse (spacing) de-energizes the coil, and the armature moves rearward to its spacing position out of the way of the start lever (Figure 10). The latter moves up and carries an associated start cam follower into the indent in its cam. The follower, in turn, moves an attached trip lever up and out of engagement with the clutch shoe lever. A selector clutch engages and makes one complete revolution (the clutch "cycles") during which the start cam holds the start lever out of the way of the armature.

2.19 As the selector clutch cycles, a spacing locklever, a stripper ball, a codebar clutch's trip follower arm, and selector levers (five for 32 typing units; eight for 33 typing units) ride on individual cams under spring pressure.

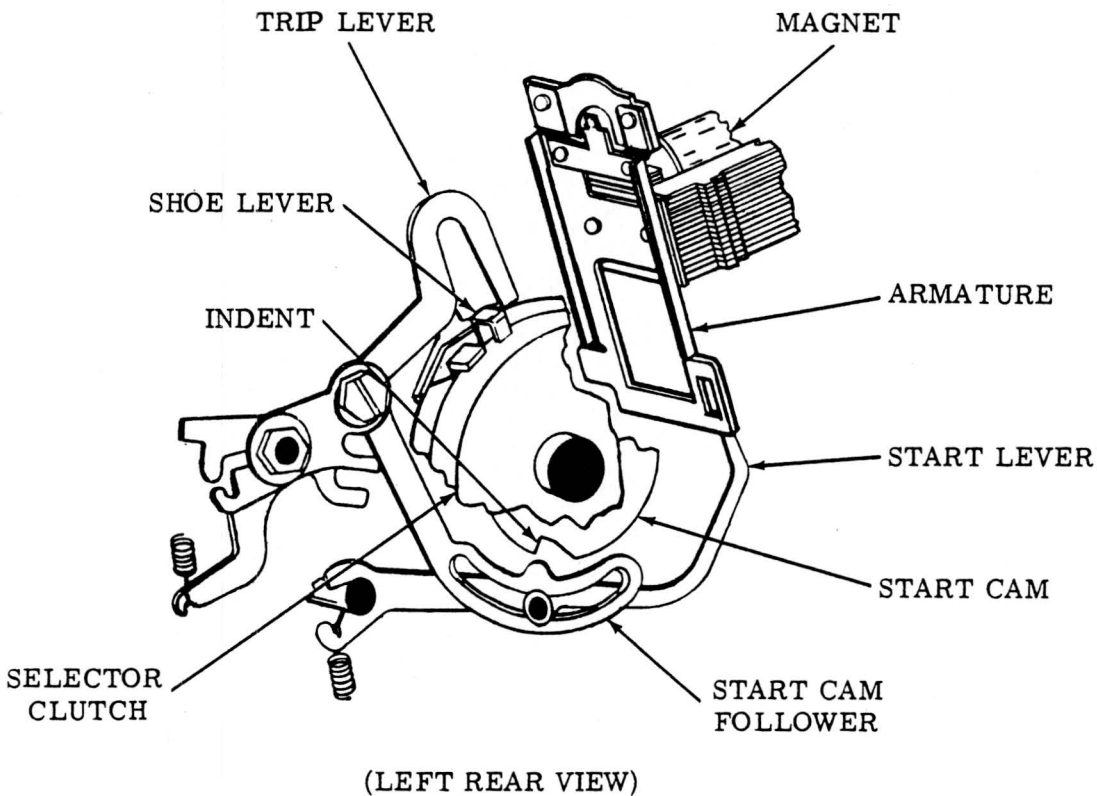

Figure 10 - Selector Trip Mechanism

2.20 Near the beginning of the cycle, the stripper cam pivots the stripper bail, which strips any push levers selected during the previous cycle from their respective selector levers and leaves them in their unselected position in front of the selector levers. The design of the selector clutch is such that, as each element of the code combination is received following the start element, an indent in the corresponding selector lever cam and the spacing locklever cam are presented to their respective levers. Since the operation of each selector linkage will be the same, only one of them is described below.

2.21 If the intelligence element is spacing, it de-energizes the magnet coil, and the armature moves to its spacing (rear) position. The spacing locklever is permitted to move up, and it holds the armature in this position during the sampling interval (Figure 11). The selector lever is prevented from moving up into the indent of its cam by the

armature, and the push lever remains in its unselected (spacing) position in front of the lever.

2.22 On the other hand, if the element is marking, the armature moves forward to its marking position, out of the way of the selector lever, and blocks the spacing locklever. The selector lever moves up into the indent of its cam, locking the armature in its marking position during the sampling interval (Figure 11) and permitting its spring-biased push lever to move rearward under the selector lever.

2.23 As the code combination is received, each intelligence element is sampled in turn, and the corresponding selector levers and push levers are positioned accordingly (Figures 4 and 5). The contours of the selector cams are such that, near the end of the cycle, they drive the selector levers and selected push levers counterclockwise (as viewed from the left) to their marking position in which

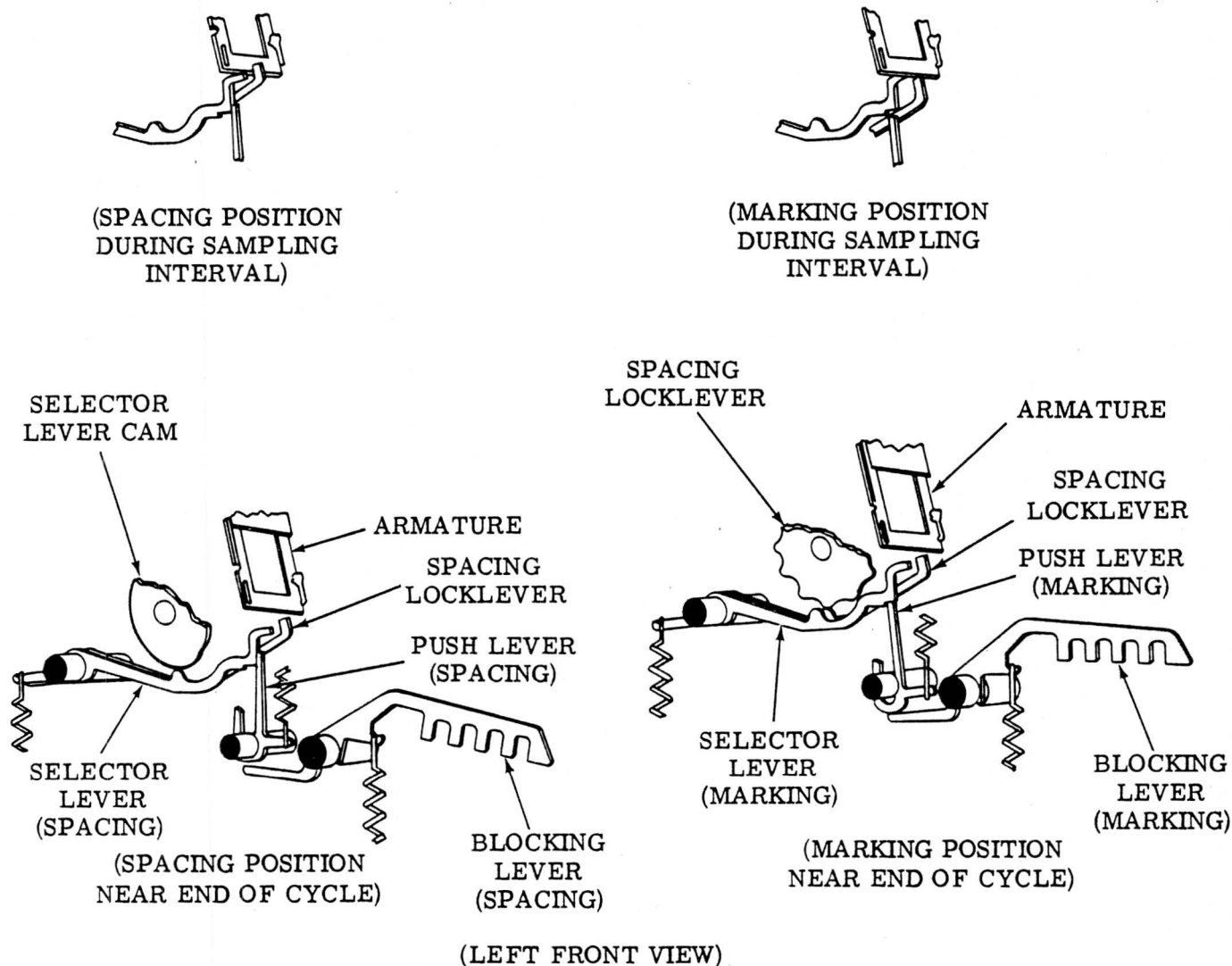

Figure 11 - Selector Mechanism

their slotted portion is up (Figure 11). The blocking levers associated with the unselected push levers remains in the spacing position in which their slotted portion is down.

2.24 Near the end of the cycle, the trip follower arm is moved rearward by its cam and trips the codebar clutch.

2.25 When the stop element (marking) is received at the end of the code combination, the armature moves to its marking position above the start lever, where it prevents the start cam follower from falling into the indent in its cam (Figure 10). In this position, the follower holds the trip lever down so that,

when the selector clutch completes its cycle, its shoe lever strikes the trip lever, and the clutch is disengaged.

2.26 As an example, assume that the letter D (1--4-) or (--3---7-) code combination is received by a 32 or 33 typing unit (Figure 3). The start pulse (spacing) trips the selector clutch, which begins its cycle. The stripper bail strips the selected push levers from the selector levers. The intelligence pulses are sampled in order, and the no. 1 and 4 or no. 3 and 7 push levers are selected. Near the end of the cycle, the selector clutch cams the no. 1 and 4 or no. 3 and 7 push levers down, and they pivot the no. 1 and 4 or no. 3

and 7 blocking levers to their marking position, while the no. 2, 3, and 5 or no. 1, 2, 4, 5, 6, and 8 blocking levers remain in their spacing position. The trip cam causes the trip follower arm to trip the codebar clutch. The stop pulse (marking) disengages the selector clutch, and the selector is returned to its stop position.

Note: The 8-level code combination given for D is the "even parity" code combination.

## B. Range Finder

2.27 For optimum operation of the typing unit, the selector must sample the code elements at the most favorable time. The range finder provides a means of determining this time by establishing a range of operating margins.

2.28 When a range finder knob is loosened, a pointer may be moved along a range scale by a handle. This changes the angular position of the trip levers and latchlevers with respect to the main shaft, and thus changes the position where the selector clutch begins and ends its cycle. The effect of this operation is to change the time in the cycle when the selector samples each code pulse.

2.29 Rotating the pointer counterclockwise from 60, the center of the scale, causes the selector to sample the trailing portion of the pulse. Rotating the pointer clockwise causes the selector to sample the leading edge. To establish the margins of the operating range, the pointer is moved first in one direction, then in the other, until errors in printing occur. The pointer is then set at the center of the range, and the knob tightened.

## C. Codebar Mechanism

2.30 The codebar mechanism illustrated in Figure 12 controls the printing and function mechanism. It is described in the appropriate description section.

2.31 As mentioned in 2.24 above, near the end of the selector cycle, the selector clutch pivots the codebar clutch's trip follower arm. The arm, through a trip shaft, pivots a trip lever out of the way of the shoe lever. The codebar clutch engages and makes one revolution (cycles) (Figures 4 and 5).

2.32 As the codebar clutch cycles, a codebar reset lever follows its camming surface under the pressure of a codebar reset bail's spring. Early in the cycle, the cam, through the reset lever, permits the reset bail to pivot counterclockwise.

2.33 There are ten codebars in the 33 typing unit and eight codebars in the 32 typing unit. As the reset bail pivots, the numbered codebars (excluding the no. 0 codebar in 32 typing units) are permitted under spring pressure to move up and to the left, and sense the position of the corresponding selector blocking levers. If a blocking lever is in its marking position (up), it permits its codebar to move all the way up and to the left, to its marking position (Figures 4 and 5). But if the blocking lever is in its spacing position (down), a projection on the lever holds the codebar down in its spacing position. The operation of the print suppression codebar is described in 2.67 through 2.71. The operation of the no. 0 codebar on 32 typing units is described in 2.56. The operation of the automatic carriage return-line feed codebar is described in paragraph 2.115 through 2.117. Function levers under the codebars and carriage slides that ride on top of the codebars sense their positions and use them to control various operations, as will be described in succeeding paragraphs.

2.34 Early in the cycle, a trip cam pivots a follower arm, which trips the function clutch (Figures 4 and 5).

2.35 Near the end of the codebar cycle, the cam, through the reset lever, pivots the reset bail clockwise. The latter thus returns the bars to their stop (down and right) position.

2.36 As an example, take the reception of the letter D (1--4-) or (--3---7-) code combination treated in 2.26. The no. 1 and 4 or no. 3 and 7 blocking levers move to their marking position, and the trip cam trips the codebar clutch, which begins its cycle. The reset bail permits the codebars to sense the position of the blocking levers. The no. 1 and 4 or no. 3 and 7 codebars are permitted by their blocking levers to move up and to the left to their marking position. The remaining bars are held down in their spacing position. The codebar clutch trips the function clutch. Near the end of the cycle, the reset bail returns the bars to their stop position.

Note: The 8-level code combination given for D is the "even parity" code combination.

## FUNCTION MECHANISM

2.37 The function mechanism illustrated in Figure 13 enables the typing unit to perform functions at the receipt of the proper code combinations. Functions are operations supplementary to printing the message, such as moving the carriage back to the left margin (carriage return) and moving the paper up (line feed) so that a new line can be printed.

2.38 As mentioned in 2.34, early in the codebar cycle, a cam pivots the function trip follower arm, which moves the function trip lever out of engagement with its shoe lever. The function clutch engages and makes

one complete revolution (cycles). A function drive cam, through a follower arm and drive arm, causes the function rocker shaft to rock. The function rocker shaft, in turn, through two drive linkages, moves a function drive bail up during the first part of the cycle and down during the middle portion (Figures 4 or 5).

2.39 The under side of the codebars are coded by a series of notches and projections. Under the codebars are a number of function levers which pivot on the same shaft as the function drive bail and are connected to the bail by springs. As the bail moves up, the springs pull the levers up so that they sense the codebars. If a lever encounters one or

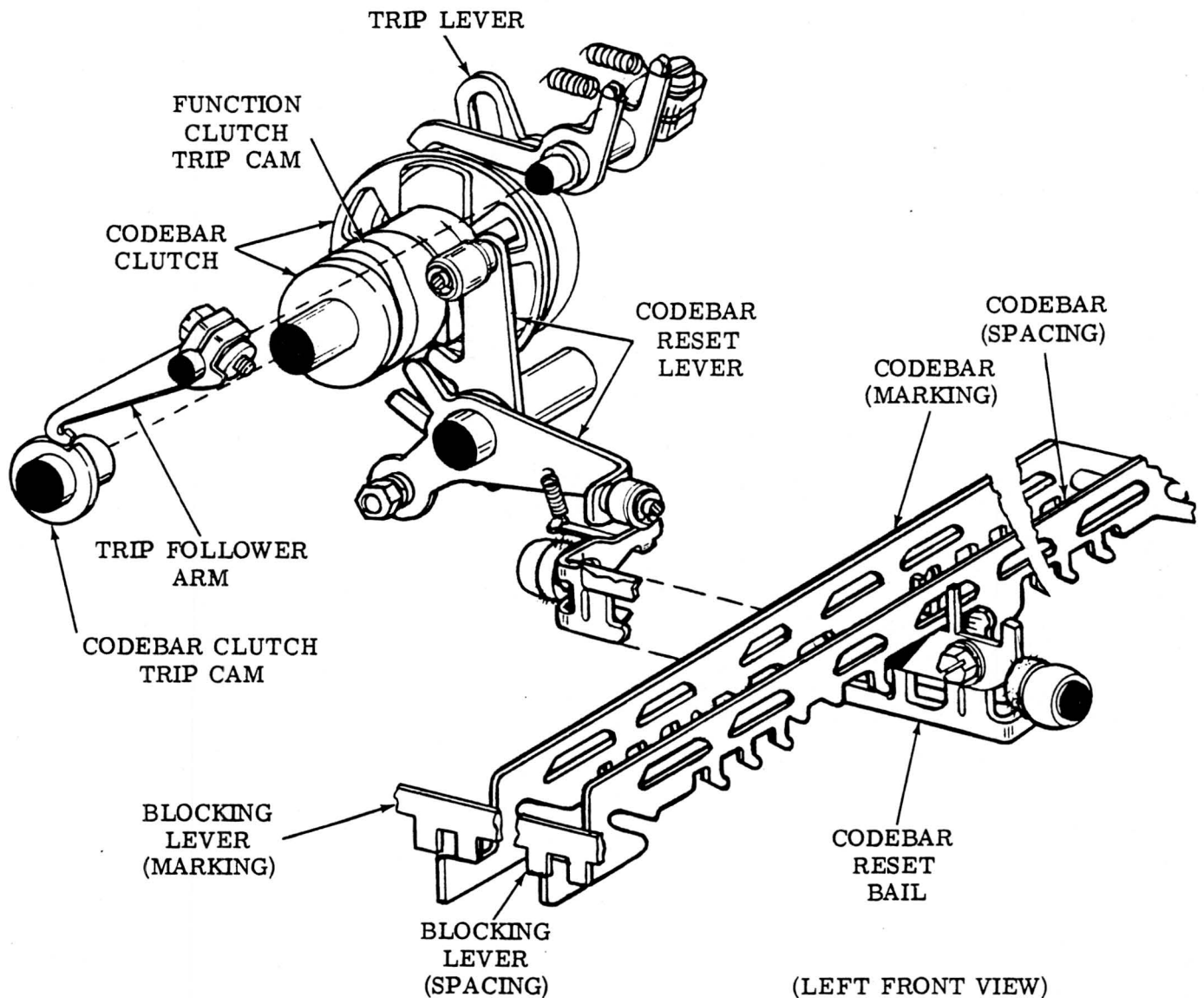

Figure 12 - Codebar Mechanism

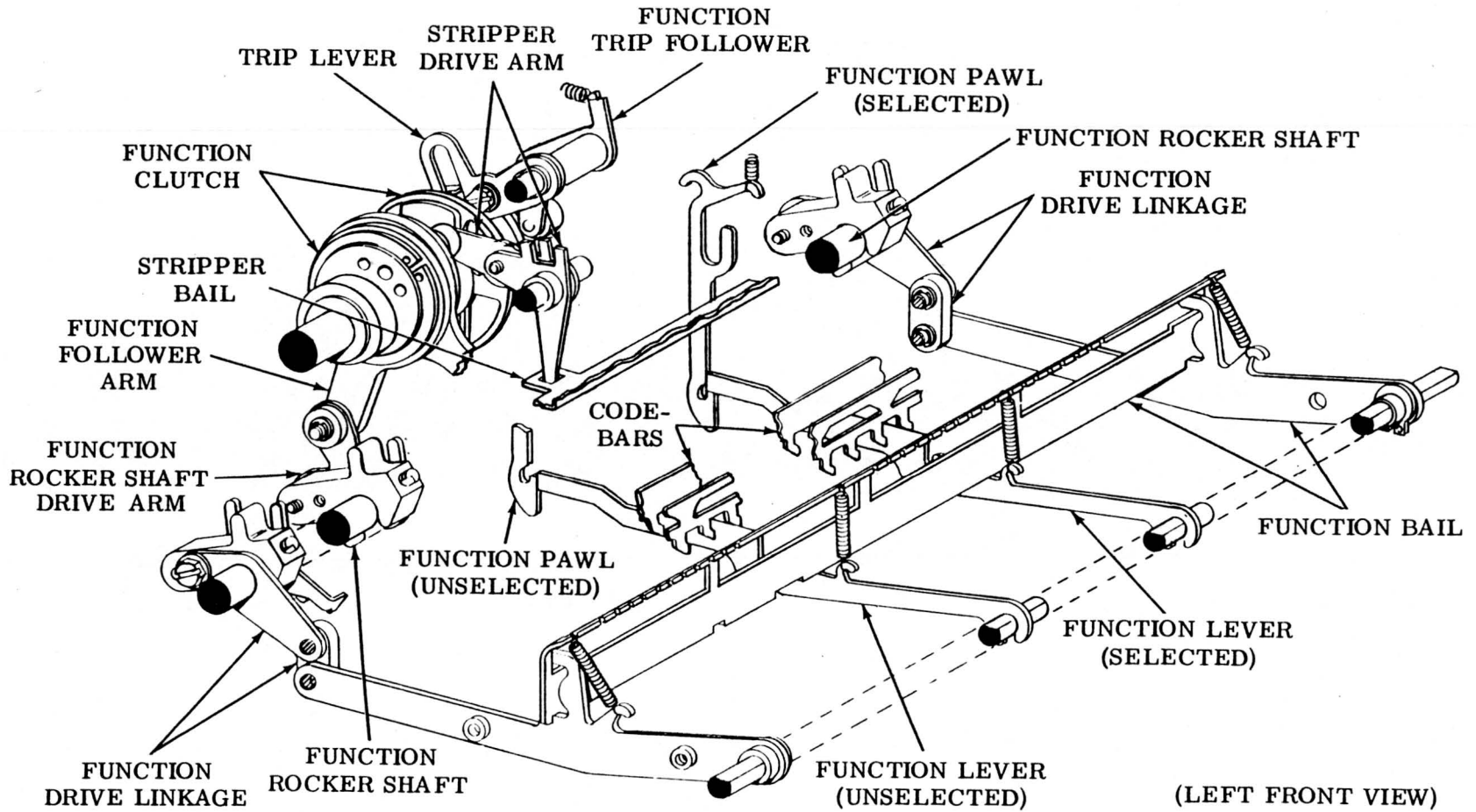

Figure 13 - Function Mechanism

more projections, it is retained in its down position against the tension of its spring. On the other hand, if the slots line up such that an opening is provided for a lever, it moves all the way up to its selected position.

2.40 In most cases, when a function lever moves up to a certain level, it is latched by an associated function pawl. Then, when the drive bail pulls the lever and latched pawl down during the middle portion of the cycle, the pawl provides the motion to effect the function.

2.41 Near the beginning of the function cycle, a cam pivots a drive arm which moves the function stripper bail forward (Figures 4 or 5). Near the end of the cycle, the cam permits the drive arm under spring pressure to move the stripper bail rearward and strip any latched function pawls from their selected function levers.

2.42 The operation of the individual function levers and pawls is covered under the individual functions.

## PRINTING

### A. General

2.43 A carriage accomplishes the printing of messages on paper or forms. The carriage is described in the appropriate description section. Printing is controlled by the code elements described in 1.03 through 1.10. Although the 32 and 33 typing unit carriages are the same, the numbers of the code elements controlling the specific operations are different.

### B. Typewheel

2.44 The characters used in printing are embossed on the cylindrical surface of a typewheel. A typewheel character arrangement is shown in Figure 14, in which the cylindrical surface is rolled out flat and illustrated from the back, or inside. The characters are arranged in 16 vertical rows of 4 characters each. For the sake of explanation, the typewheel is divided into clockwise and counterclockwise fields to indicate in which direction the typewheel is rotated to select the rows. The rows are then numbered 1 through 8 in each direction from the borderline between the fields. The characters in each row are designated the "1st" through the "4th" from top to bottom.

2.45 Again, for the sake of explanation, a printing area is indicated in Figure 14. This is the area the selected character must be in if it is to be printed when the print hammer strikes the typewheel. As shown in the figure, the borderline between the fields is under the printing area when the typing unit is in the stop condition. During the first part of each function cycle, vertical and rotary positioning mechanisms impart separate, but simultaneous, motions to the typewheel to select the proper character. The rotary mechanism rotates it either clockwise or counterclockwise to align the proper row with the printing area. The vertical mechanism raises it to place the proper character in the printing area. During the latter part of the function cycle, the typewheel is returned to its stop position.

2.46 For example, assume that the code combination representing the letter D is received by the typing unit. The rotary mechanism rotates the typewheel four and one-half rows clockwise, and the vertical mechanism raises it two characters, plus the distance below the printing area. The print hammer drives it forward, and the typewheel imprints the letter "D" on the paper or form. The positioning mechanisms then return the typewheel to its stop position.

### C. Power

2.47 As the function clutch cycles (2.38), an eccentric cam imparts oscillating motion through a carriage drive link to a carriage drive bail (Figure 6). The bail pivots rearward during the first part of the cycle and forward to its stop position during the latter part (Figures 4 or 5). In doing so, it causes a power bail on the carriage to pivot first clockwise (as viewed from the left), then counterclockwise (Figure 15). The power bail has two rollers that move along the drive bail and permit it to receive the motion regardless of the carriage's position along the printing line.

### D. Rotary Positioning

#### Direction of Rotation

2.48 Which way the typewheel rotates from the stop position is determined by the no. 3 code element on 32 typing units and the no. 4 element on 33 typing units. If this element is marking, the wheel is rotated counterclockwise. If it is spacing, the wheel is rotated clockwise.

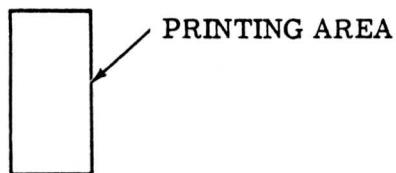

1st	▽	&	%	\$	#	▽	▽	!	A <sup>M</sup> SP	(	)	*	+	,	-	.	/
2nd	G	F	E	D	C	B	A	@	H	I	J	K	L	M	N	O	
3rd	7	6	5	4	3	2	1	0	8	9	:	;	<	=	>	?	
4th	W	V	U	T	S	R	Q	P	X	Y	Z	[	\	]	↑	←	
	8	7	6	5	4	3	2	1	1	2	3	4	5	6	7	8	

CLOCKWISE
COUNTERCLOCKWISE

VERTICAL ROWS

(SHOWN IN STOP POSITION)

Figure 14 - Typical Typewheel Character Arrangement (As Printed)

Note: Numbers in parentheses apply to 33 typing units. Associated numbers outside parentheses apply to 32 typing units.

the no. 3 (4) codebar is down, and the drive arm is up, where it engages the right rack, but not the left.

2.49 When a code combination is received in which the no. 3 (4) element is marking, the no. 3 (4) codebar moves up and to the left early in the codebar cycle. A following slide, through a linkage, moves a rotary drive arm down so that it engages a left rotary rack, but not a right one. If the no. 3 (4) element is spacing, the alternate condition exists, in which

2.50 A rotary drive bail is held against the power bail by a spring. As these bails rock clockwise (as viewed from the left) during the first part of the function cycle, the drive arm, which is attached to the rotary positioning bail, moves toward the front. If the arm is down (no. 3 (4) element marking), it pulls the left rack with it, and the rack rotates a rotary

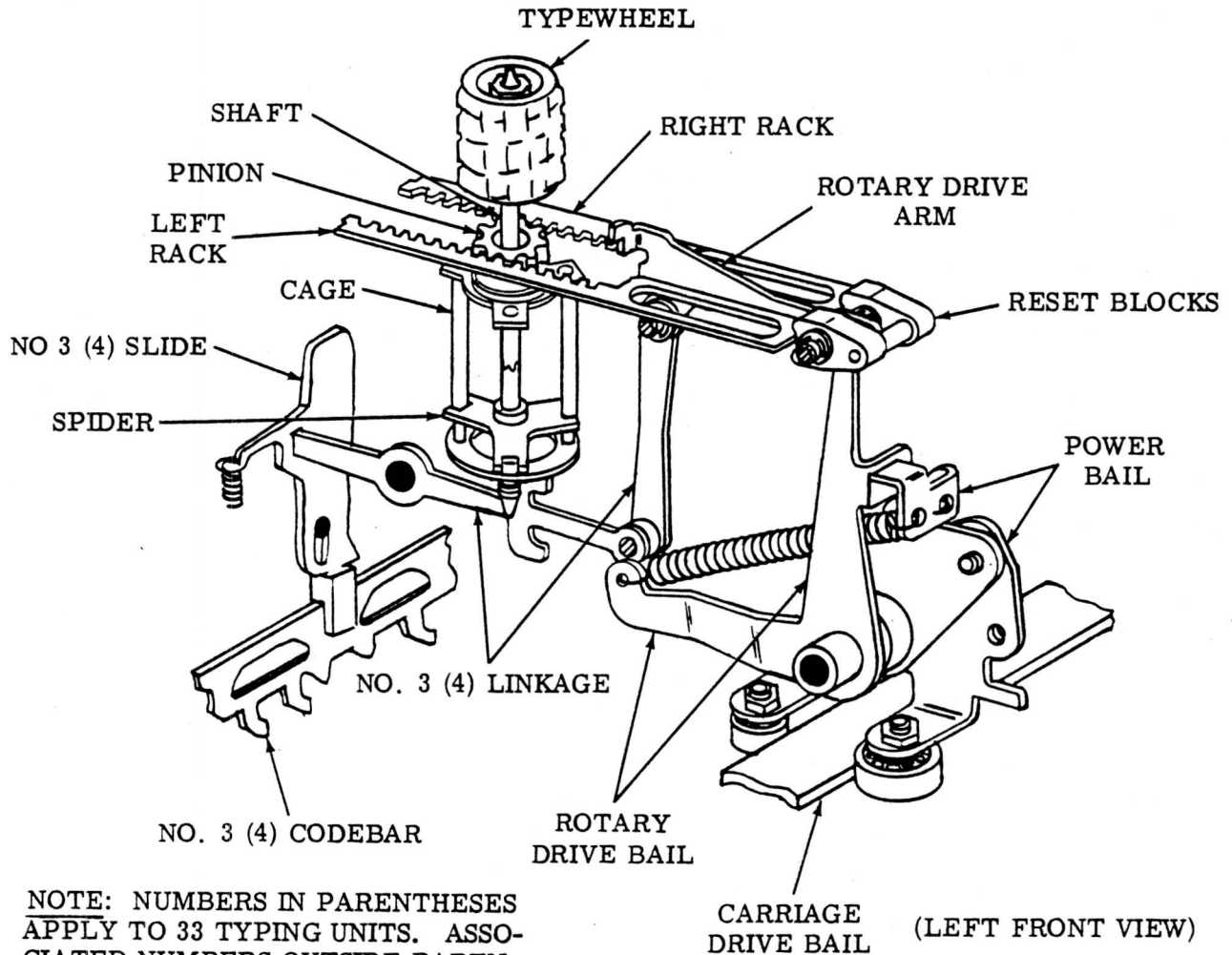

NOTE: NUMBERS IN PARENTHESES APPLY TO 33 TYPING UNITS. ASSOCIATED NUMBERS OUTSIDE PARENTHESES APPLY TO 32 TYPING UNITS.

Figure 15 — Rotary Positioning Mechanism

pinion, a cage, a spider, a shaft, and the attached wheel counterclockwise (as viewed from the top). On the other hand, if the arm is up (no. 3 (4) element spacing), it pulls the right rack toward the front, and rotates the typewheel clockwise. As the power bail and rotary drive bail rock back to their stop position during the latter part of the function cycle, two reset blocks on the drive bail return the racks and the typewheel to their stop position.

#### Degree of Rotation

2.51 How far the typewheel rotates in either direction is determined by the no. 1 and no. 2 code elements and the no. 0 codebar on the 32 typing unit and the no. 1, 2, and 3 code elements on the 33 typing unit. (See Figures 16 and 17.)

Note: Numbers in parentheses apply to 33 typing units. Associated numbers outside parentheses apply to 32 typing units.

2.52 When the no. 1 (2) and no. 2 (3) code elements are both spacing, the corresponding codebars and their following rotary stop slides remain down. A common stop slide, which is moved by the other two, also remains down. As one of the racks is pulled frontward, the opposite rack is driven rearward by the pinion and strikes the common stop (the one nearest the front). This permits the pinion to rotate the typewheel enough for vertical row "1" or "2" (depending on the position of the no. 0 (1) codebar, as covered in 2.56 below) of either the clockwise or counterclockwise field to be aligned with the

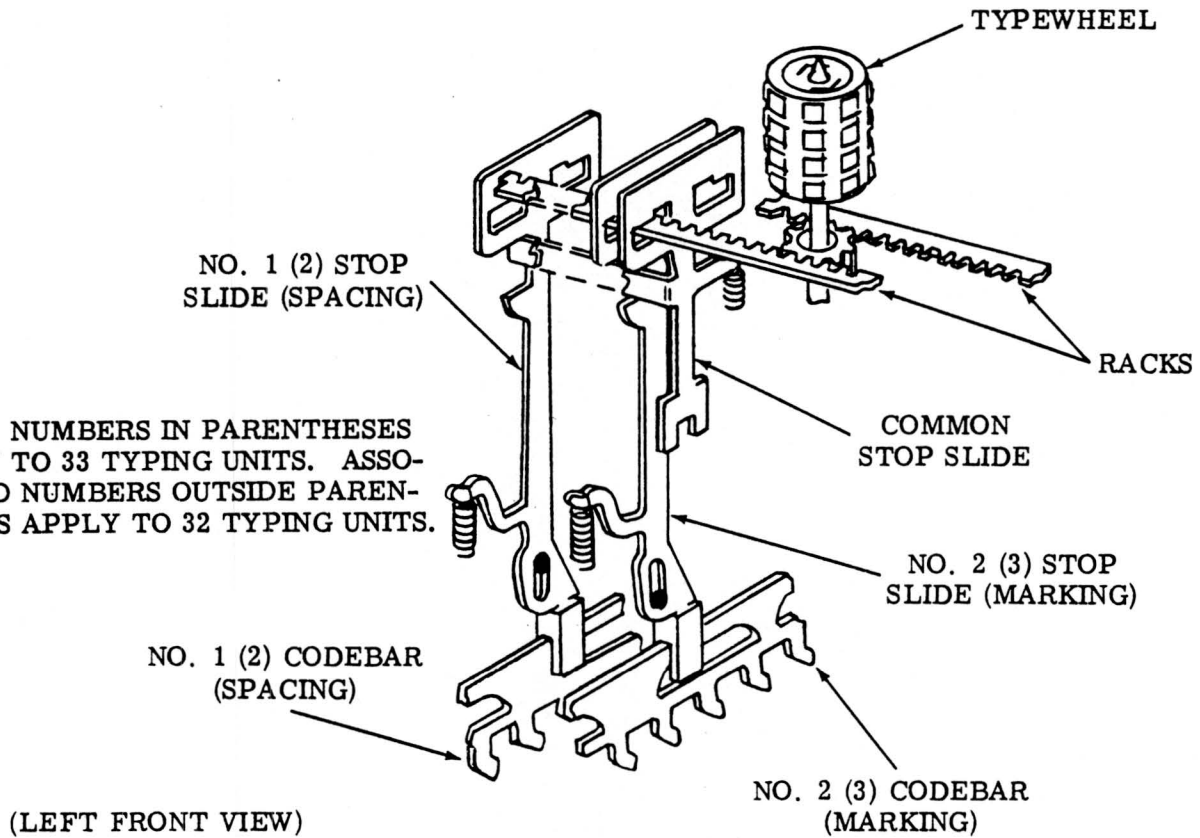

**NOTE:** NUMBERS IN PARENTHESES APPLY TO 33 TYPING UNITS. ASSOCIATED NUMBERS OUTSIDE PARENTHESES APPLY TO 32 TYPING UNITS.

Figure 16 — Rotary Positioning Mechanism

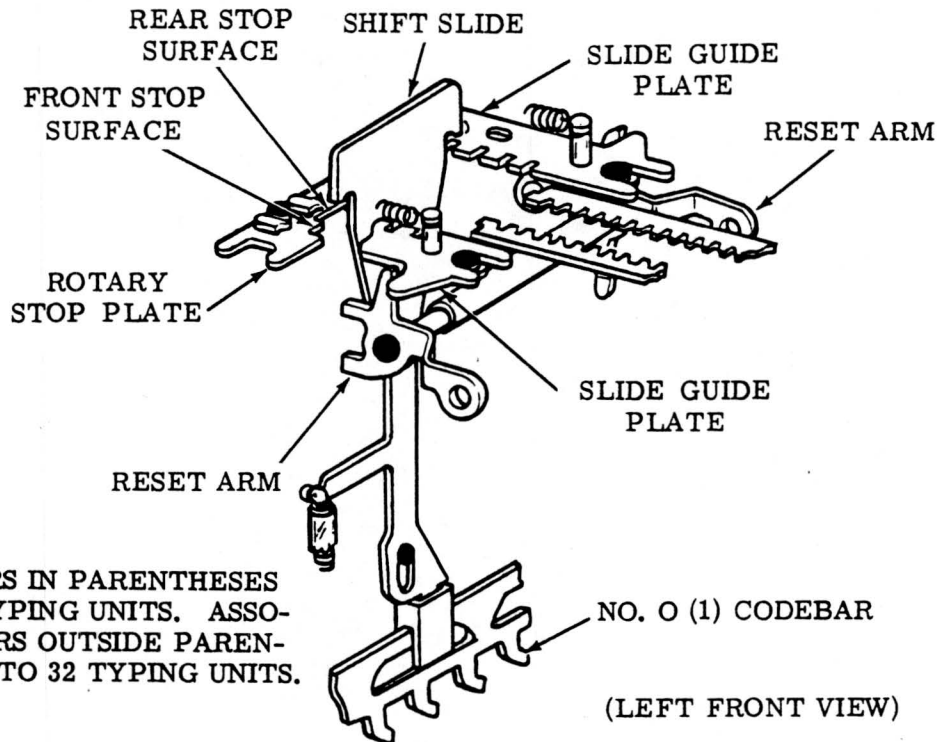

**NOTE:** NUMBERS IN PARENTHESES APPLY TO 33 TYPING UNITS. ASSOCIATED NUMBERS OUTSIDE PARENTHESES APPLY TO 32 TYPING UNITS.

Figure 17 — Rotary Positioning Mechanism

printing area at the time of printing. When a rack is stopped, the rotary bail stops, and its spring extends as the power bail continues its travel.

2.53 When the no. 1 (2) element is marking and the no. 2 (3) is spacing, the no. 1 (2) codebar and slide moves up, and the no. 1 (2) slide lifts the common slide. In this position, holes in the common slide permit whichever rack is moving toward the rear to pass through and strike the no. 2 (3) slide (second from the front), which is down. Thus, the vertical row "3" or "4" is aligned with the printing area.

2.54 When the no. 2 (3) element is marking and the no. 1 (2) is spacing, the no. 2 (3) slide is moved up and lifts the common stop. The rack that is moving rearward passes through holes in these slides and strikes the no. 1 (2) slide (third from the front), which is down. Thus, the vertical row "5" or "6" is aligned with the printing area.

2.55 When both the no. 1 (2) and no. 2 (3) elements are marking, the no. 1 (2) and no. 2 (3) and common slides are moved up and permit the rack to pass through their holes and strike the shift slide (farthest from the front). Thus, the vertical row "7" or "8" is aligned with the printing area.

#### Odd or Even Rows

2.56 Whether the odd or even rows are selected depends on the position of the no. 0 codebar on 32 typing units and the no. 1 codebar on 33 typing units. When this codebar is up, the even rows are selected; when it is down, the odd rows are selected. In 33 typing units, the no. 1 code element controls the position of this codebar. In 32 typing units, it is controlled by the letters-figures shift mechanism, which responds to the "letters" and "figures" code combinations.

#### (a) 33 Typing Unit:

(1) The upper portion of the stop slides moves up and down in slots in two guideplates. When one of the racks moves toward the rear and strikes one of the slides, the slides and guideplates are pushed toward the rear until the shift slide strikes the rotary stop plate. During the latter part of the function cycle, the guides and slides are returned to their stop position by reset arms, which are

part of the printing mechanism. (See 2.63 through 2.71.)

(2) When the no. 1 code element is spacing, the no. 1 codebar and its following slide remain down, and the shift slide strikes the front stop surfaces on the stop plate. This results in vertical row "1," "3," "5," or "7" being aligned with the printing area at the time of printing.

(3) On the other hand, when the no. 1 code element is marking, the no. 1 codebar and the shift slide are up where the latter presents a narrower outline to the stop plate. Thus, when the slide moves toward the rear, it fits into a cutout in the plate and strikes rear stop surfaces. The difference results in one more row rotation of the typewheel, and vertical row "2," "4," "6," or "8" is aligned with the printing area.

#### (b) 32 Typing Unit Letters-Figures Shift:

(1) When the 32 typing unit is in the "letters" condition, the no. 0 codebar is blocked by a letters blocking lever (Figure 18), whose extension engages one of the codebar's slots. When the codebar bail rocks to the left early in each codebar cycle, the no. 0 codebar is held in its down position. Thus, the odd rows will be selected, as covered in 2.56 (a).

(2) On receipt of the "figures" code combination, the codebars permit a figures function lever to rise to its up position, where it is latched by its function pawl. Then, as the lever and pawl are pulled down by the function bail during the middle portion of the function cycle, an extension on the pawl moves the letters blocking lever to its down position, where it is latched by its pawl and no longer blocks the no. 0 codebar. The typing unit is now in "figures" condition, and the no. 0 codebar will move to its up position each codebar cycle until the "letters" code combination is received. This results in the selection of the even rows as covered in 2.56 (a).

(3) On receipt of the "letters" code combination, the codebars permit a letters function lever to move to its up position, where it is latched by its function pawl. As the lever and pawl are pulled

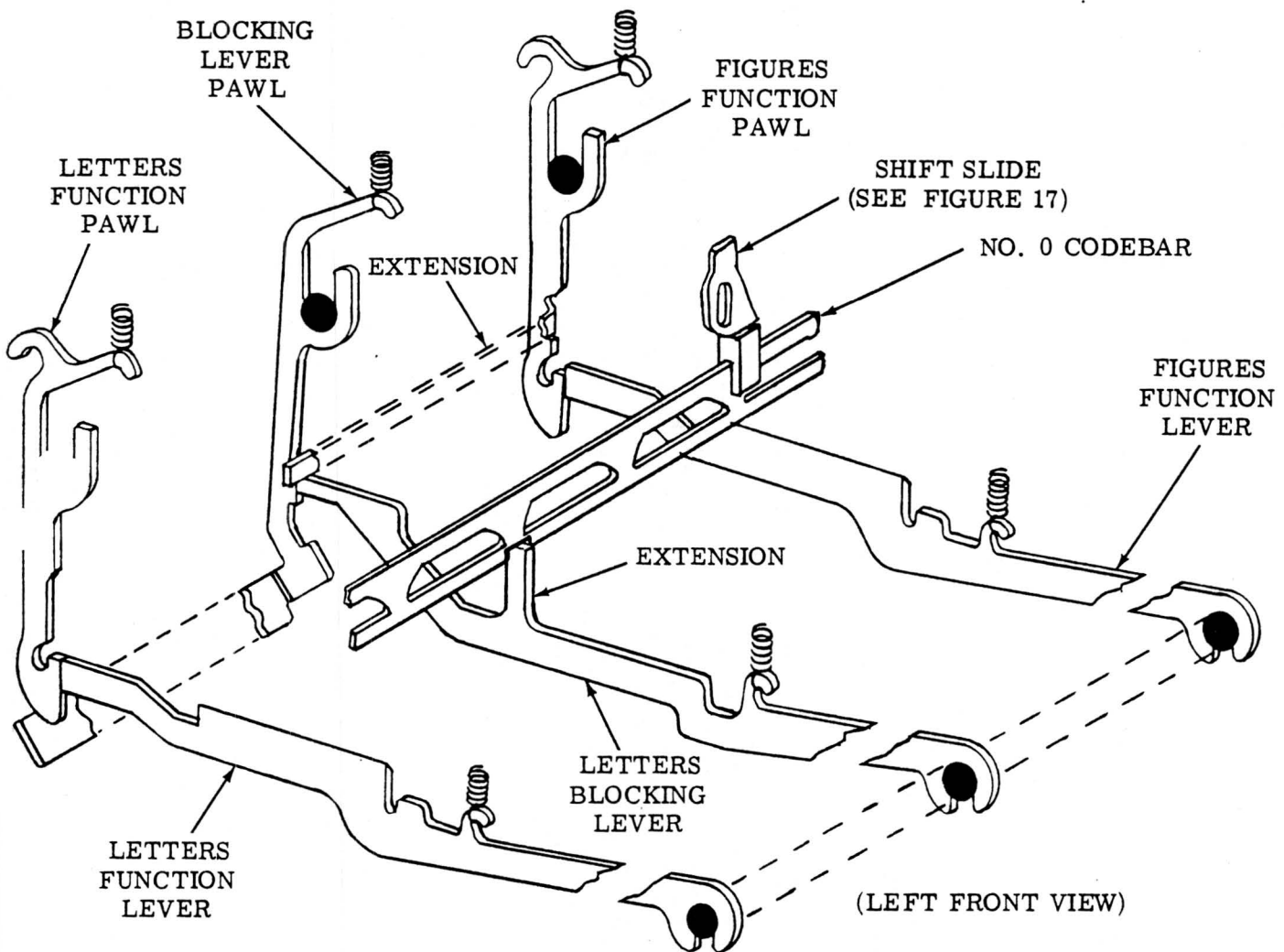

Figure 18 — Letters-Figures Shift Mechanism

down by the function bail during the middle portion of the cycle, the pawl contacts a slanting extension of the blocking lever's pawl and moves it rearward until it unlatches the blocking lever. The latter is then permitted to move up and block the no. 0 codebar. Thus the typing unit is returned to the "letters" condition.

#### E. Vertical Positioning

2.57 The vertical positioning mechanism positions the typewheel so that the proper character in the selected row is in the printing area at the time of printing. It is controlled by the no. 4 and no. 5 code elements on 32 typing

units and by the no. 5 and no. 7 elements on 33 typing units. (See Figure 19.)

Note: Numbers in parentheses apply to 33 typing units. Associated numbers outside parentheses apply to 32 typing units.

2.58 A vertical drive bail is held against the power bail by a spring. When these bails rock clockwise (as viewed from the left) during the first part of the function cycle, the vertical drive bail, through a drive arm, lifts the spider, typewheel shaft, and typewheel. How far the typewheel is raised is determined by three stop arms that are positioned in response to the no. 4 (5) and no. 5 (7) code elements. When the

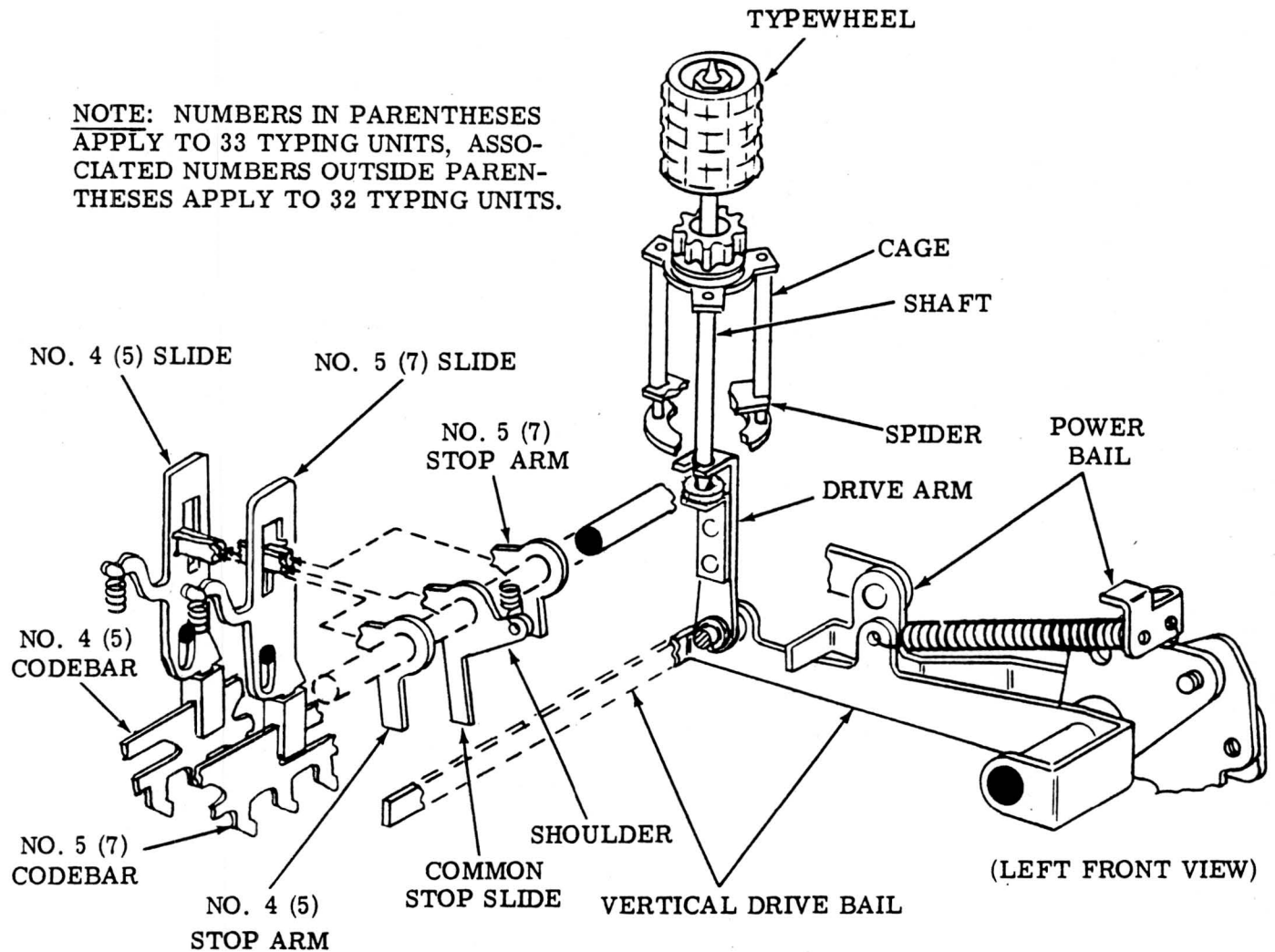

Figure 19 — Vertical Positioning Mechanism

drive bail encounters an arm, it is stopped and its spring extends as the power bail continues to pivot. The spider moves up and down the bars of the cage, and thus permits rotary motion to be transferred to the typewheel regardless of its vertical position. During the last half of the function cycle, the parts are returned to their stop position.

2.59 When a code combination is received in which the no. 4 (5) and no. 5 (7) code elements are spacing, the no. 4 (5) and no. 5 (7) codebars and their following vertical slides remain in their spacing position (down), and no motion is transferred to the stop arms. As the rear extension of the drive bail rises, it strikes the common stop arm, which is the longest.

This permits the typewheel to be raised to the point where the first character in the selected row is in the printing area at the time of printing.

2.60 When the no. 4 (5) element is spacing and the no. 5 (7) is marking, the no. 5 (7) codebar moves its following slide up early in the codebar cycle. The slide pivots the common and the no. 5 (7) stop arm rearward, out of the way of the drive bail. The bail thus strikes the no. 4 (5) arm (the second longest), and the second character in the selected row is placed in the printing area.

2.61 When the no. 4 (5) element is marking and the no. 5 (7) spacing, the no. 4 (5) slide pivots the no. 4 (5) and common stop arm



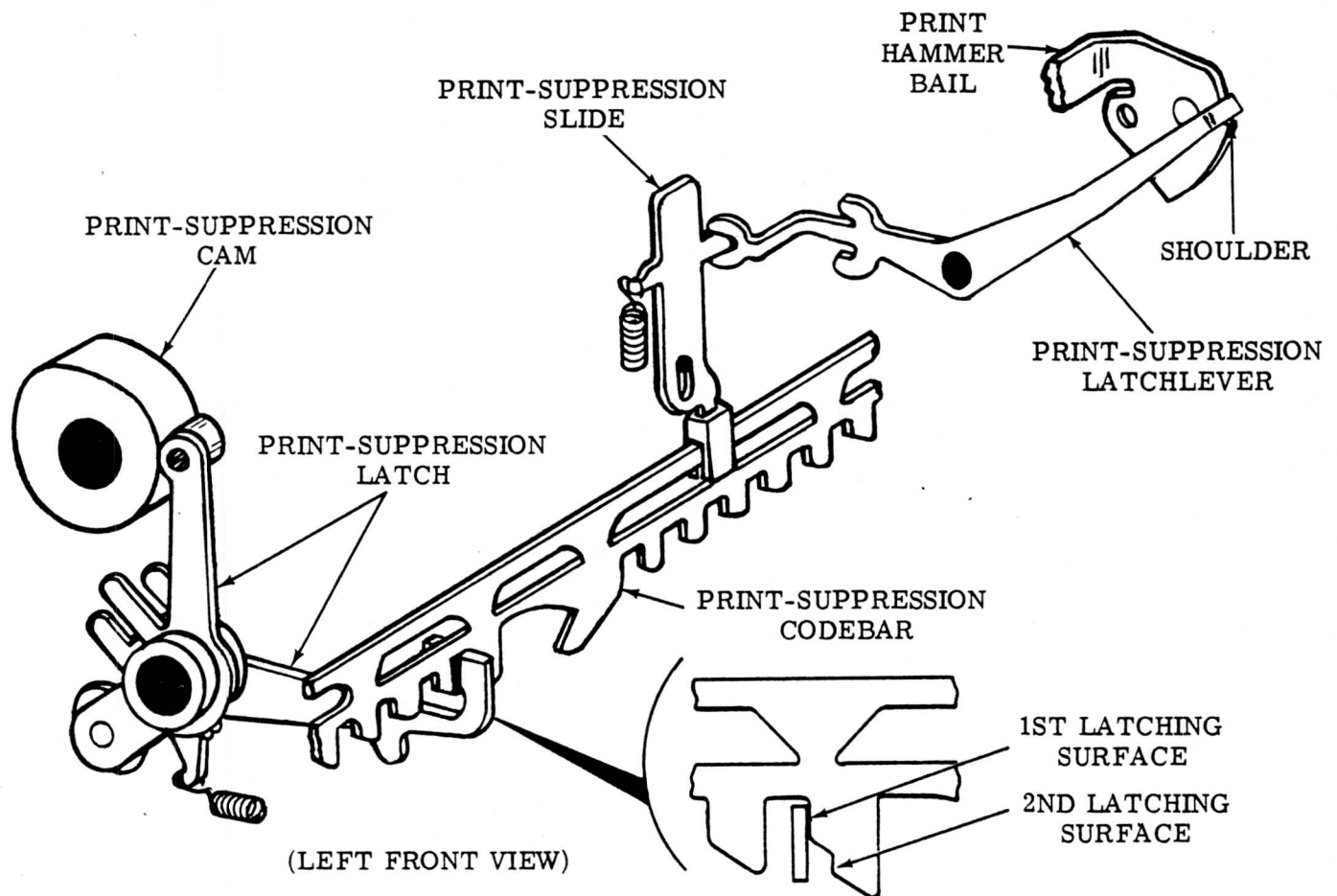

Figure 21 — Print Suppression Mechanism

2.66 During the last half of the cycle, the power bail returns the printing parts to their stop position, and a print reset arm attached to the print bail returns the print hammer to its stop position, where it is latched by the print trip lever.

#### Printing Suppressed

2.67 The printing suppression mechanism is illustrated in Figure 21.

2.68 Whenever a function code combination is received, printing is suppressed. As the other codebars rise early in the codebar cycle, a print-suppression codebar is held down by a print-suppression latch (Figures 4 or 5). Early in the function cycle, after any of the function levers has been selected, the latch is pivoted away from the codebar by a print-suppression cam on the function clutch.

2.69 If no function lever has been selected, the print-suppression codebar moves up and to the left to its selected position. A print-suppression slide follows the motion of this codebar and pivots a print-suppression latch-lever out of the way of the shoulder on the print hammer bail. Thus, when the print trip lever releases the bail, its hammer is permitted to strike the typewheel, and printing occurs as covered in 2.64 through 2.66.

2.70 On the other hand, if any function lever moves up to its selected position, it engages one of a series of notches in the print-suppression codebar. When the latch releases the codebar, the selected function lever prevents it from moving all the way to its selected position. Thus, the print-suppression latch-lever is not pivoted and catches the shoulder when the hammer bail is released by the trip lever. The hammer does not reach the typewheel, and printing is suppressed.

2.71 As the selected function lever moves down and withdraws from the notch in the print-suppression codebar, the latch, which has been returned to its stop position, engages a second latching surface on the codebar. This prevents the codebar from rising when the function lever is withdrawn, thus causing printing to occur before the print hammer is completely reset in its stop position. The print-suppression codebar is completely reset with the rest of the codebars at the end of the code-

bar cycle, and at that time the latch engages the first latching surface (Figures 4 or 5).

G. Ribbon Mechanism

2.72 The ribbon mechanism is illustrated in Figure 22.

2.73 The ribbon mechanism supplies the ink for printing. As the typing unit operates, the mechanism feeds the ribbon from one spool to the other, and reverses the direction of feed

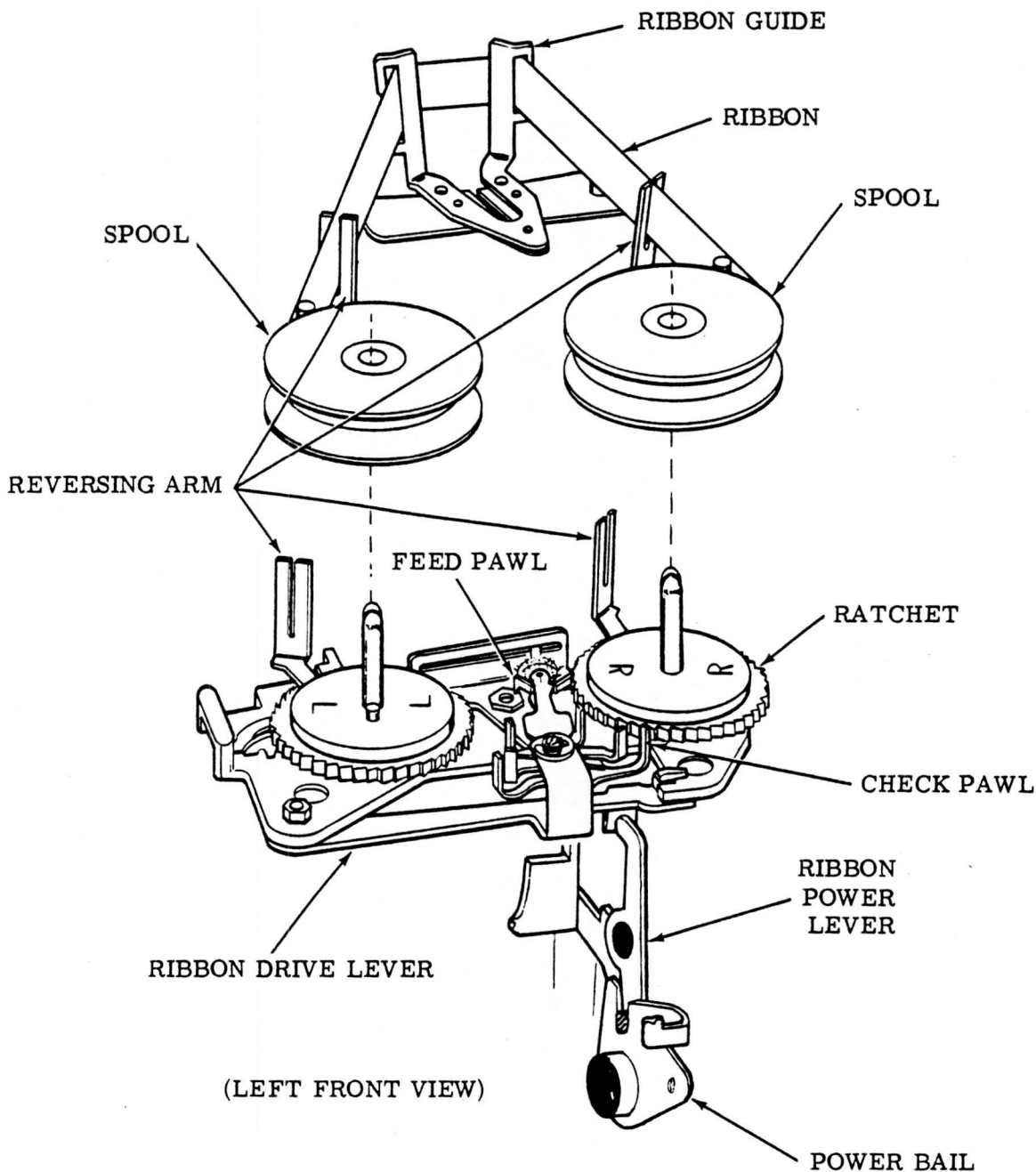

Figure 22 - Ribbon Mechanism

when the spool is nearly depleted. It is described in the appropriate description section.

2.74 As the power bail rocks during the first part of the function cycle, it pivots a ribbon power lever, which moves a ribbon drive lever rearward. A feed pawl which rides on the drive lever acts on a ratchet to rotate a ribbon spool. A check pawl drops into the succeeding tooth and detents the ratchet until it is again rotated during the next operation.

2.75 The mechanism continues to rotate one spool until the other is nearly depleted. An eyelet in the ribbon then engages a ribbon reversing arm. As the eyelet is pulled against the arm, the latter moves to a point where a detent spring shifts it to its alternate position, where one of its reversing extensions falls ahead of an extension on the feed pawl. As the pawl moves frontward, during the last half of the cycle, it strikes the arm's extension and is pivoted to its alternate position against the other ratchet. In doing this, it strikes an extension on the check pawl and pivots it to its alternate position against the other ratchet. The depleted spool is now rotated to take up the ribbon until the other spool is nearly depleted, when reversal again takes place.

2.76 The ribbon guide, which is spring biased upward, is mounted so that it will slide up and down on posts. As the print pivot shaft turns during the first half of the cycle (see 2.65 above), the two pivot arms permit the guide to rise so that it is between the selected character and the paper midway in the cycle. At this time the print hammer drives the typewheel and the ribbon against the paper. During the last half of the cycle, the pivot arms retract the guide and ribbon to their stop position so that the printed characters are visible.

#### H. Example

##### 32 Typing Unit

2.77 Assume that the typing unit is in the "letters" condition and that the letter D code combination (1--4-) is received. The no. 1 and no. 4 codebars move up and to the left to their marking position early in the codebar cycle. Since the no. 3 codebar is down, the rotary drive arm moves up and engages the right rack. Since the no. 1 codebar is up and the no. 2 is down, the no. 1 and common stop slides are moved up. Since the typing unit is in the "letters" condition, the no. 0 codebar keeps the

shift slide down. Since the no. 4 codebar is up and the no. 5 is down, the no. 4 and common stop arms are pivoted out of the way of the vertical drive bail.

2.78 As the power bail rocks clockwise (as viewed from the left) during the first part of the function cycle, the following occurs:

- (a) The rotary drive arm pulls the right rack forward and rotates the typewheel clockwise.
- (b) The left rack, driven by the typewheel's pinion, moves rearward, passes through a hole in the common slide, and strikes the no. 2 stop slide.
- (c) The stop slides and their guides are moved rearward, and the wider outline of the shift slide strikes the front stop surfaces of the stop plate.
- (d) Thus, the proper vertical row is aligned with the printing area.

2.79 Concurrent with the rotary positioning, the vertical drive bail moves up until it strikes the no. 5 stop arm, and the letter D is placed in the printing area.

##### 33 Typing Unit

2.80 Assume that the letter D code combination (--3---7-) is received. The no. 3 and 7 codebars move up and to the left to their marking position early in the codebar cycle. Since the no. 4 codebar is down, the rotary drive arm moves up and engages the right rack. Since the no. 2 codebar is down and the no. 3 codebar is up, the no. 3 and common stop slides are moved up. Since the no. 1 codebar is down, the shift slide is down. Since the no. 5 codebar is down and the no. 7 codebar is up, the no. 7 and common stop arms are pivoted out of the way of the vertical drive bail.

Note: The 8-level code combination given for D is the "even-parity" code combination.

2.81 As the power bail rocks clockwise (as viewed from the left) during the first part of the function cycle, the following occurs:

- (a) The rotary drive arm pulls the right rack frontward and rotates the typewheel clockwise.

(b) The left rack, driven by the typewheel pinion, moves rearward, passes through holes in the no. 3 and common slides, and strikes the no. 2 stop slide. The stop slides and their guides are moved rearward, and the wider outline of the shift slide strikes the front stop surfaces of the stop plate. Thus, the vertical row "5" is aligned with the printing area.

2.82 Concurrent with the rotary positioning, the vertical drive bail moves up until it strikes the no. 7 stop arm, and the second

character in vertical row "5" is placed in the printing area. (See Figure 14.)

32 and 33 Typing Units

2.83 Since no function lever has been selected in either case given, the print-suppression codebar moves up and to the left early in the cycle and moves the print-suppression latch-lever away from the print hammer bail. Midway in the cycle, the right reset arm moves the print trip lever out of engagement with the shoulder on the hammer bail, and the bail snaps

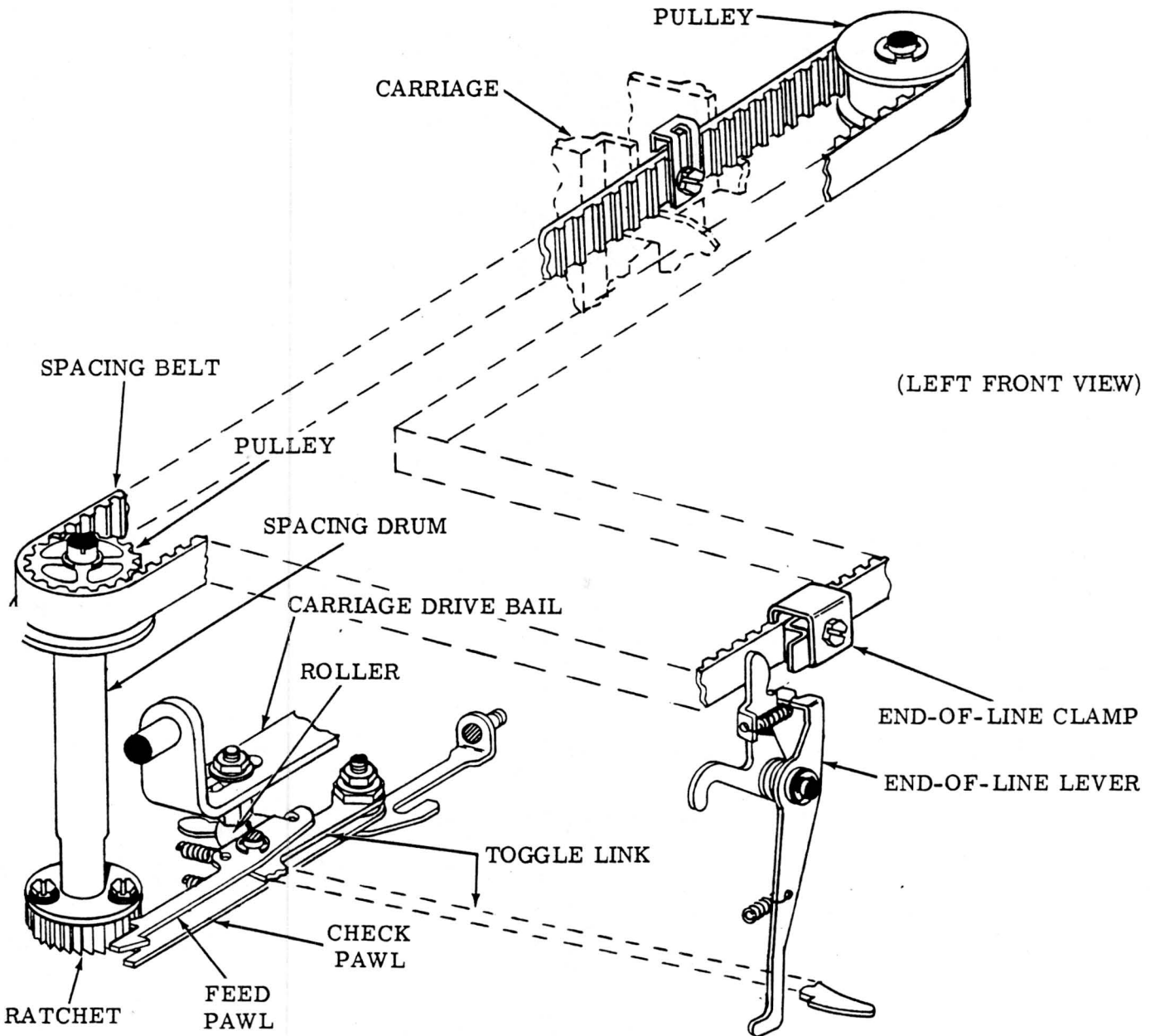

Figure 23 - Spacing Mechanism

rearward and drives the letter D and the ribbon against the paper. During the last half of the cycle, the parts are returned to their stop position.

## SPACING

### A. General

2.84 The spacing mechanism illustrated in Figure 23 positions the carriage so that the printed characters are properly horizontal on the paper. Each time a character is printed, the carriage is positioned one character to the right. Spacing is suppressed on all functions except "space" when spacing occurs and printing is suppressed. At the end of the printing line, spacing is suppressed, and the typing overprints. When the "carriage return" function is received, the carriage is returned to the left margin. The spacing mechanism is described in the appropriate description section.

Note: With the automatic carriage return-line feed feature, spacing is not suppressed at the end of a line. Also, the typing unit does not overprint at the end of a line. The carriage is returned automatically to the left margin when it reaches a predetermined point. (See 2.115 through 2.117.)

### B. With Printing

2.85 As the carriage drive bail moves rearward during the first half of the function cycle, a small roller mounted near its left pivot permits a toggle linkage, consisting of a spacing feed pawl and toggle link, to buckle under spring pressure. The pawl moves to the right and engages the next tooth on a ratchet, which is part of a spacing drum. When the roller is moved forward during the last half of the function cycle, it unbuckles the toggle linkage, and the pawl is moved to the left and rotates the drum one tooth. This motion is imparted by a pulley at the top of the drum to a spacing belt, which is looped around a pulley on the right side of the typing unit. The spacing belt, in turn, moves the carriage to the right one space against the tension of a large carriage return spring. The carriage is held in this position by a check pawl, which engages the spacing drum's ratchet.

### C. Space Suppression

2.86 The space suppression mechanism is illustrated in Figure 24.

### 2.87 On Functions:

(a) On every function except "space," spacing as well as printing must be suppressed. When a character to be printed is received, the print-suppression codebar moves up and to the left, as detailed in 2.67 through 2.71. In doing so, it pivots a space suppression latch so that it is moved to the right, out of the way of the toggle linkage. This permits the linkage to buckle and effect spacing as described in 2.85 above.

(b) On the other hand, when a function is received, the print-suppression codebar remains down and to the right, as described in 2.67 through 2.71, and thus does not pivot the space-suppression latch. In this position, the space-suppression latch engages the toggle linkage and prevents it from buckling all the way, and the feed pawl does not move far enough to the right to engage the next tooth. Thus, the spacing drum is not rotated, and the carriage is not spaced.

2.88 At End-of-Line: When the carriage reaches the right margin, a clamp on the spacing belt pivots an end-of-line lever counterclockwise. In this position, a latching surface on the spacing toggle link engages the end-of-line lever and prevents the linkage from buckling and effecting spacing. Thus, spacing is suppressed, and the typing unit overprints at the right margin until the "carriage return" code combination is received.

Note: With the automatic carriage return-line feed feature, spacing is not suppressed at the end of a line. Also, the typing unit does not overprint at the end of a line. The carriage is returned automatically to the left margin when it reaches a predetermined point. (See 2.115 through 2.117.)

### D. Space Function

2.89 The space function mechanism is illustrated in Figure 24.

2.90 When the "space" code combination is received, the codebars permit a space function lever to move up to its selected position early in the function cycle. This motion is transferred, through a space linkage, to a space lever, which moves the print-suppression latch out of the way of the toggle linkage. Thus, the spacing linkage is permitted to buckle

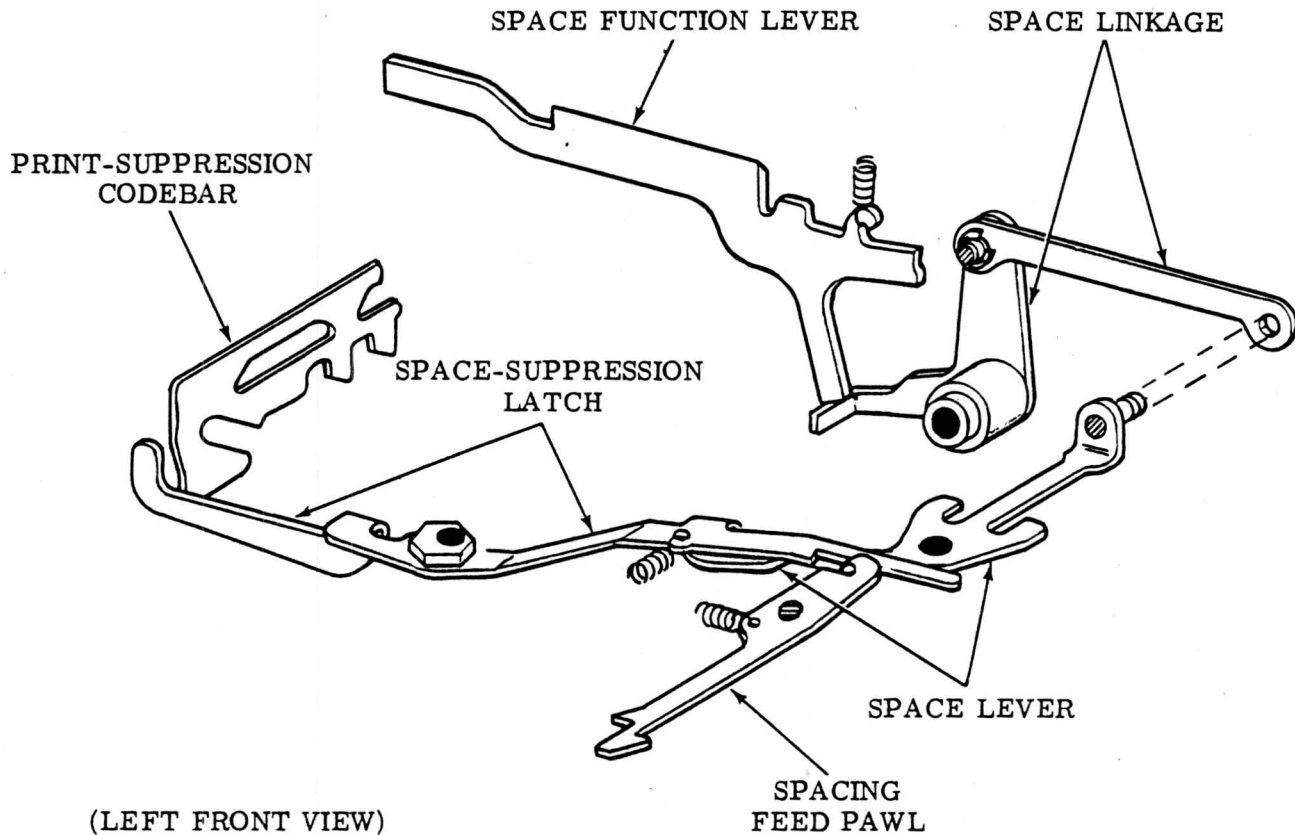

Figure 24 — Space Function and Space-Suppression Mechanism

completely and effect spacing as covered in 2.85. Printing is suppressed as described in 2.67 through 2.71.

#### E. Carriage Return

2.91 The carriage return mechanism is illustrated in Figure 25.

2.92 When the "carriage return" code combination is received, the codebars permit the function lever to move up to its selected position during the first part of the function cycle. In this position, the lever is latched by its function pawl. As the function bail moves the lever and the pawl downward during the middle portion of the cycle, an extension on the pawl pivots a carriage return activating lever. This motion is transferred through a carriage return linkage to a carriage return lever, which is moved forward, where it is latched by both the carriage return latch-lever and the carriage return latch.

2.93 In moving forward, the carriage return lever carries the spacing feed and check pawls out of engagement with the ratchet on the spacing drum. The carriage return spring then pulls the carriage back to the left margin. As the carriage nears the left margin, a lobe plate on the carriage strikes the carriage return unlatch lever and causes the carriage return unlatch lever to unlatch the carriage return lever, but the carriage return lever latch continues to keep the carriage return lever latched in its front position. The carriage return lever remains latched by the carriage return lever latch until a code combination is received which does not suppress spacing. When a "non space-suppression" code combination is received, the spacing feed pawl moves to the right to engage the next tooth on the ratchet on the spacing drum. During this action, the spacing feed pawl strikes the carriage return lever latch and releases the carriage return lever. The latter moves rearward under spring pressure and permits the spacing feed and check pawls to again engage the spacing drum feed ratchet.

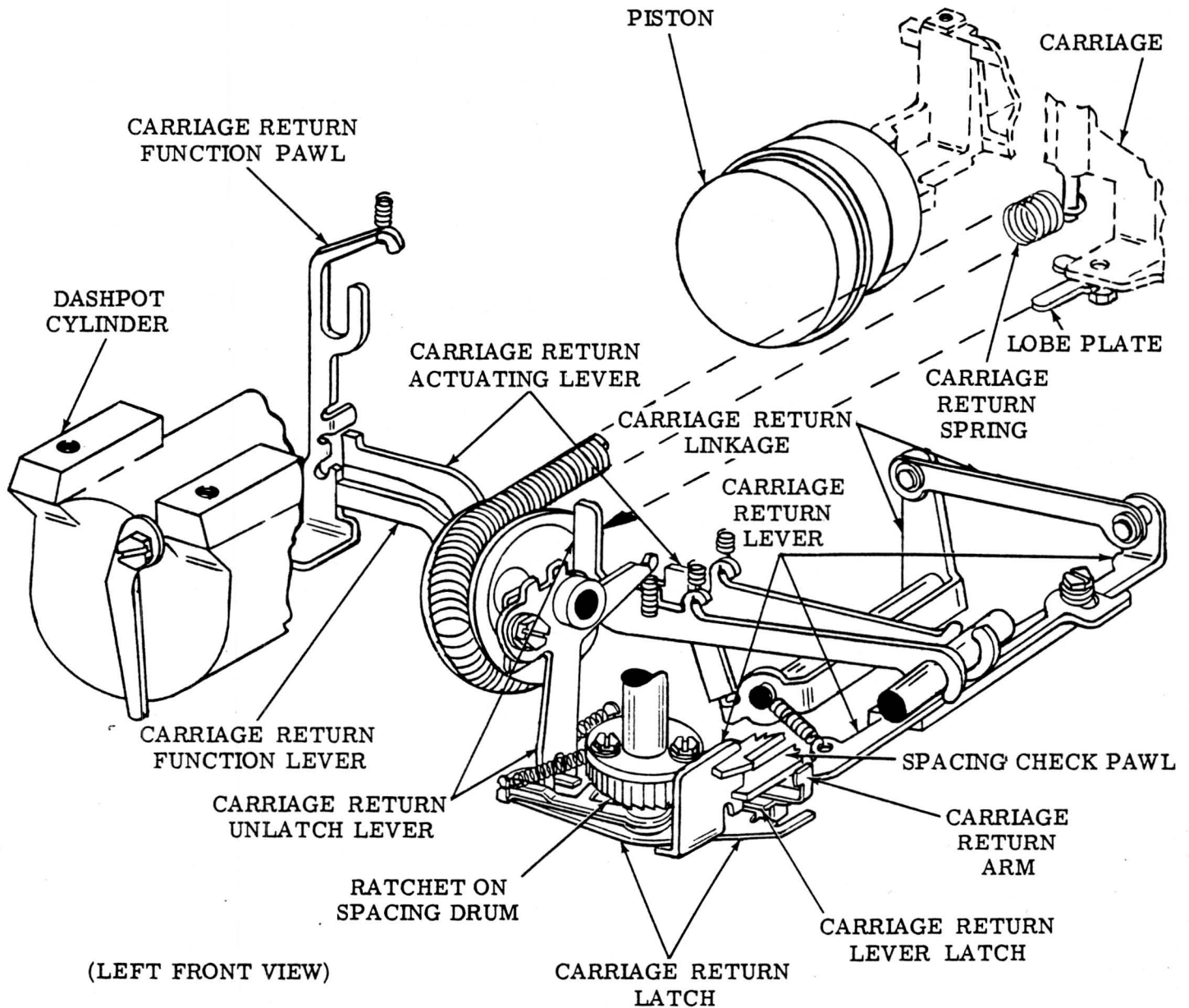

Figure 25 — Carriage Return Mechanism

Late in the function cycle, the carriage return function pawl is stripped from its function lever by the stripper bail.

2.94 As the carriage approaches the left margin at relatively high speed, a piston on the carriage enters a dashpot cylinder and compresses the air ahead of it. The air forms a cushion which slows the carriage and then, as it escapes through a small, variable hole at the left end of the cylinder, permits the carriage to be stopped at the left margin without excessive shock.

## PAPER OR FORM FEEDING

### A. Friction Feed Typing Units

2.95 The paper feed mechanism used on friction feed typing units is illustrated in Figure 26.

2.96 The paper feed mechanism positions the paper vertically, so that the printed characters are properly located in lines on the paper. It feeds the paper on receipt of the "line feed" code combination. It may be adjusted for either single or double line feed.

2.97 The paper feeds off a roll and is led around a platen that positions it vertically in front of the typewheel. A paper guideplate leads it down around the platen. A pressure roller, which sits in a cutout in the guide, holds the paper against the platen, so that it is fed when the platen rotates. A curved wire shaft biases the pressure roller and the guideplate against the paper. The pressure is released by a lever on the right end of the shaft. The paper is held around the front of the platen by a wire guide and is led up out of the typing unit by a deflector guide. It can be manually fed by a knob on the left end of the platen

2.98 When the "line feed" code combination is received, the codebars permit the line feed function lever to move up to its selected position early in the function cycle. The function lever, in turn, moves up a line feed blocking lever, which is engaged by the latching surface of a line feed drive link. As the left drive arm on the function rocker shaft moves down during the middle portion of the cycle, a line feed arm engages the blocking lever and moves it down. This motion is transferred, through a line feed linkage, to a pawl which engages a ratchet on the left end of the platen. The pawl rotates the platen and

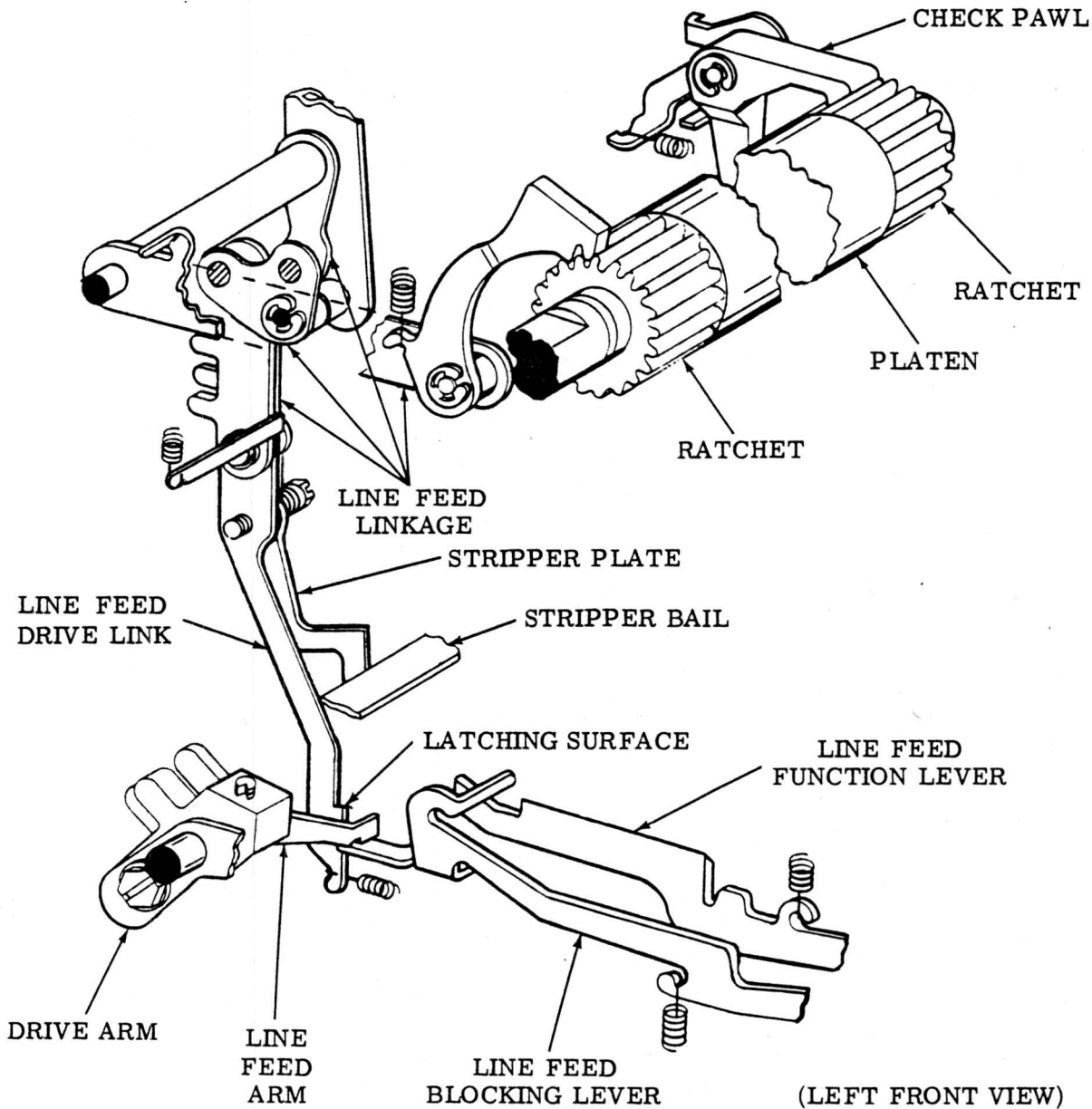

Figure 26 — Paper Feed Mechanism (Friction Feed).

thus feeds the paper up one or two lines of printing, depending on what the mechanism is adjusted to do.

2.99 The pawl is guided into the teeth by two guide posts. A check pawl riding on a ratchet at the right end of the platen holds the paper in position until the platen is again rotated. At the end of the cycle, the function stripper bail contacts a stripper plate and strips the drive link from the blocking lever, which is returned to its unoperated position.

## B. Sprocket Feed Typing Units

### General

2.100 The platen drive mechanism (Figure 27) rotates the platen and positions forms vertically so that the printed characters are properly located in lines on the forms. The platen drive mechanism is activated through the form-out mechanism (Figures 28 and 29) and controlled by the line feed clutch. It feeds forms upon receipt of either the "line feed" or "form-out" code combination and may be adjusted for single or double line feed.

2.101 Forms feed from a conveniently located stack of forms. They feed under a paper roll spindle and, if used, a low-paper arm and a paper-out arm. From here, the forms, led by a paper guideplate, engage sprocket pins and advance between the platen and two paper guides until positioned vertically in front of the type-wheel. The two paper guides and a wire guide hold the forms to the front of the platen and insure that the forms advance around the platen while moving up and out of the typing unit. As the forms move out of the typing unit, they go over the paper roll spindle, which separates in-coming from out-going forms.

Note: Forms can be manually fed by depressing the center knob and rotating the platen knob located on the left end of the platen.

### Line Feed

2.102 When a "line feed" code combination is received, the codebars permit the line feed function lever to move up to its selected position early in the function cycle, where it is latched by its associated function pawl. During the middle portion of the function cycle, the line

feed function pawl is pulled down and, by way of a lug, contacts and pulls down the line feed strip pawl (Figure 28) until a tail on the line feed strip pawl contacts the line feed lever. The line feed strip pawl continues downward and rotates the line feed lever and line feed lever extension. While rotating, the line feed lever extension contacts the trip lever extension. Further downward rotation causes the trip lever to rotate and trip the line feed clutch.

2.103 The tripping of the line feed clutch causes it to become engaged and to rotate. This rotation, directly, through the platen drive mechanism (Figure 27) causes the platen to rotate and effects line feed.

2.104 Late in the function cycle, the line feed strip pawl, in its downward movement, contacts the line feed strip function lever and cams itself out of engagement with the lug on the line feed function pawl. When this happens, the line feed strip pawl returns to its unoperated position and allows the line feed lever and line feed lever extension to rotate upward under spring tension. Thus, the line feed lever extension rotates out of contact with the trip lever extension. Almost simultaneously, the trip lever, under spring tension, rotates down and catches a shoe lever and disengages the line feed clutch.

2.105 Single or double line feed is accomplished, depending upon whether the trip lever, after being tripped, catches the first or second shoe lever. The particular shoe lever caught by the trip lever depends upon the time between the trip lever's tripping of the line feed clutch and the subsequent contact with a shoe lever to disengage the line feed clutch. This time is related to the amount of downward travel of the line feed strip pawl before its tail makes contact with the line feed lever. This downward travel is controlled by an adjustment.

### Form-Out

2.106 When a "form-out" code combination is received, the codebars permit the form-out function lever (Figure 29) to move to its selected position early in the function cycle, where it is latched by its associated function pawl. During the middle portion of the function cycle, the form-out function pawl is pulled down and contacts the extension of the latchlever assembly. Further downward travel of the form-out function pawl rotates the latchlever assembly and causes the form-out lever to unlatch. Then,

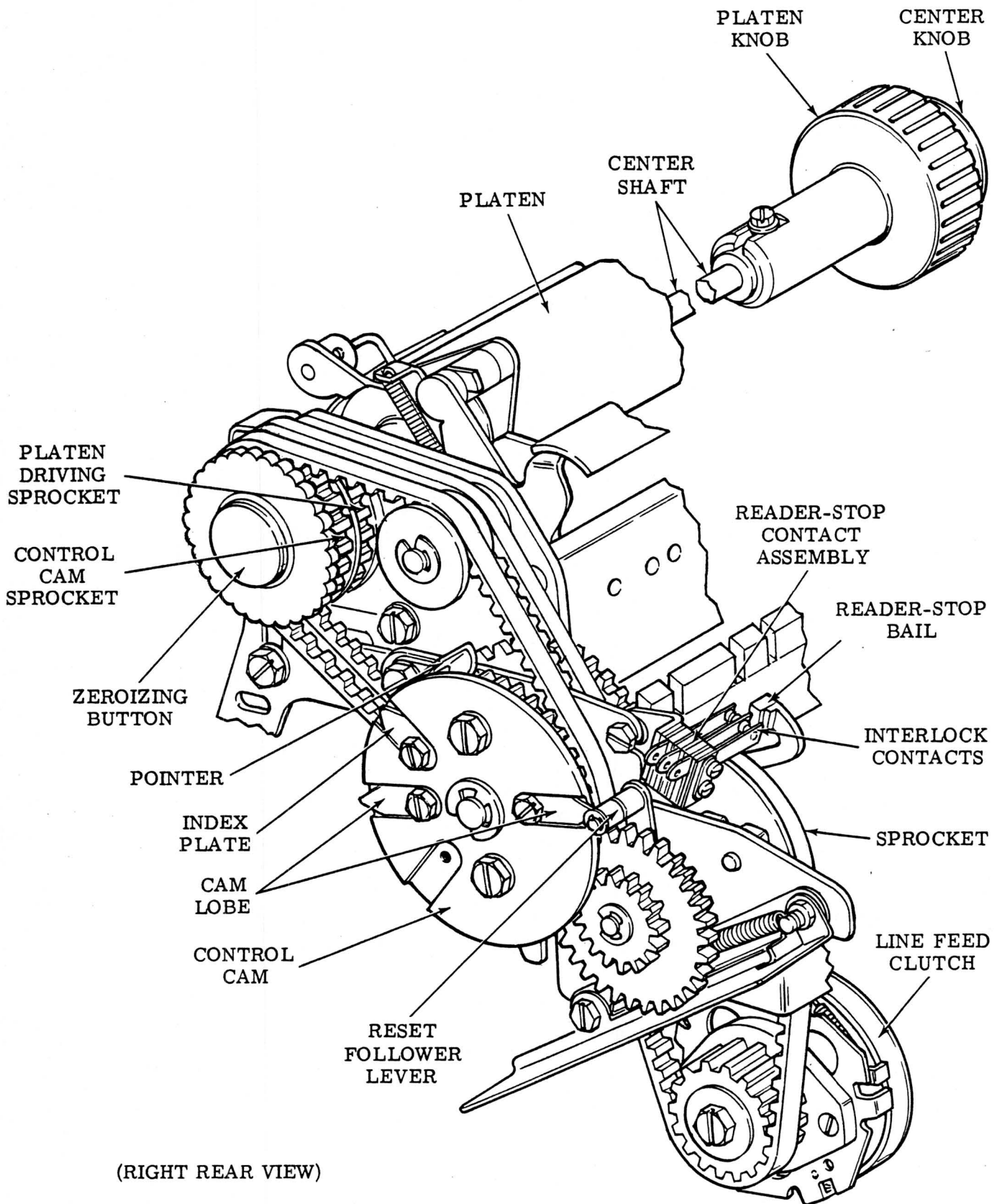

Figure 27 — Platen Drive Mechanism (Sprocket Feed)

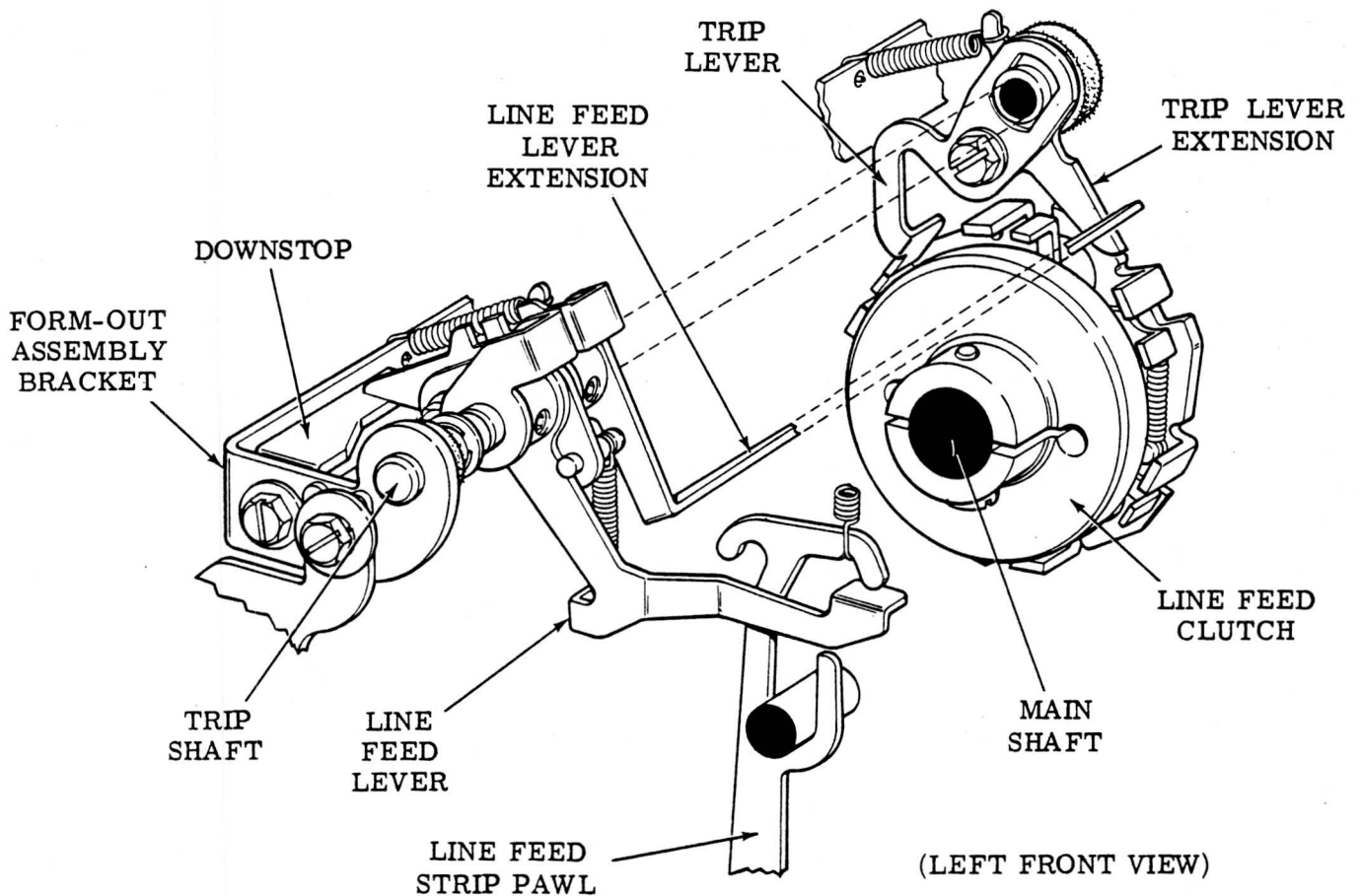

Figure 28 — Form-Out Mechanism (Sprocket Feed)

the formout lever and the form-out lever extension, under spring tension, rotates downward, and the form-out lever extension contacts the trip lever extension and causes the trip lever to rotate and trip the line feed clutch.

2.107 The tripping of the line feed clutch causes it to become engaged and to rotate. This rotation, directly, through the platen drive mechanism (Figure 27), causes the platen to rotate and effects form-out.

Note: At the end of the function cycle, the function stripper bail strips the form-out function pawl from the form-out function lever, and the form-out function pawl, under spring tension, assumes its unoperated position. This action allows the latchlever assembly to rotate upward, under spring tension, to a position where it will latch the form-out lever (2.110) when permitted.

2.108 As long as the form-out lever stays in its operated position, the platen will rotate and feed out a form, except as regulated by the control cam. Whenever the platen rotates, the control cam, being related to the platen by belts and gears, also rotates. The rotating control cam, through cam lobes, a reset follower lever, and a reset bail, initiates the action to terminate the advance of the platen and, thus, the feeding of a form.

2.109 When a cam lobe contacts the reset follower lever and rotates it toward the rear of the typing unit, a reset bail also rotates and, in rotating, pivots the form-out lever extension away from the trip lever extension. As a result, the trip lever is allowed to engage the next shoe lever and disengages the line feed clutch, which terminates form-out.

2.110 With form-out just terminated, the reset follower lever remains on the high part of a cam lobe, and the form-out lever is blocked by the reset bail from rotating to its latched position. When a "line feed" code combination is received, however, the control cam will rotate, and the reset follower lever will move from the high point of a cam lobe. This causes the reset bail to rotate downward and move away from the form-out lever extension. As a result, the form-out lever is permitted to be latched in its unoperated position, and ready to receive a "form-out" command.

Note: For reasons explained in 2.110, at the end of each form-out cycle, the form has to be fed one line before form-out can again be executed.

#### Composite Operation of Mechanism

2.111 Whenever the platen rotates after receiving either a "line feed" or "form-out" code combination, the control cam sprocket also rotates. Through belts and gears, the rotation of the control cam sprocket also causes the control cam to rotate. The gearing is arranged so that, with a given form length, one complete rotation of the control cam sprocket results in one complete rotation of the control cam. A variety of form lengths can be accommodated by selecting and installing an appropriate set of gears.

2.112 Several "line feed" code combinations may be received before a "form-out" code combination is received. Thus, a form may be advanced several printing lines before a command to feed out the form is received. The control cam remembers the number of printing lines that have been advanced, and, when a "form-out" code combination is received, it controls the amount a form is fed out, so that the succeeding form is positioned into the same starting position as the preceding form.

2.113 Upon receipt of a "form-out" code combination by an Automatic Send-Receive Teletypewriter Set, the reader-stop bail is rotated toward the front of the typing unit by the form-out lever extension. This action causes the interlock contacts of the reader-stop contact assembly to be operated with the following results:

(a) A pair of normally closed contacts are opened during the "form-out" function. This stops the tape reader from trans-

mitting and prevents the typing unit from printing characters "on the fly," while a form is being advanced.

(b) A pair of normally open contacts are closed. This keeps the typing unit motor operating in case the typing unit is turned off before the form-out cycle is completed. Thus, synchronization of the forms is maintained.

#### END-OF-LINE BELL

2.114 As the carriage moves to the right during printing, the carriage upper rear roller makes contact with and depresses a latch which is secured to a lever mounted on the rear rail. As the latch is depressed, the lever is rotated and moves the automatic carriage return-line feed codebar to the right a short distance, where a notch in the codebar permits the bell function lever to move up to its selected position, where it is latched by its function pawl. During the middle portion of the function cycle, the lever moves the pawl down against the pressure of the latter's spring. When the stripper bail strips the pawl late in the function cycle, the pawl moves up and causes a clapper mounted on a wire spring to snap up and ring a gong.

Note: An alternative method of performing the same operation proceeds in the same manner as above, except that a projection on the carriage picks up the automatic carriage return-line feed codebar at a predetermined point and moves the codebar to the right a short distance until a notch in the codebar permits the bell function lever to move up to its selected position.

#### AUTOMATIC CARRIAGE RETURN-LINE FEED

2.115 As described for the alternate method in the note above, the carriage picks up the automatic carriage return-line feed codebar at a predetermined point and moves it to the right. When the carriage reaches the right margin, a notch in the codebar permits an automatic carriage return-line feed function lever to move up to its selected position, where it is latched by its function pawl.

2.116 The automatic carriage return-line feed function lever, in turn, moves the line feed blocking lever up to where it is latched by the line feed link. Line feed then occurs as described in 2.95 through 2.99 or 2.102 through 2.105.

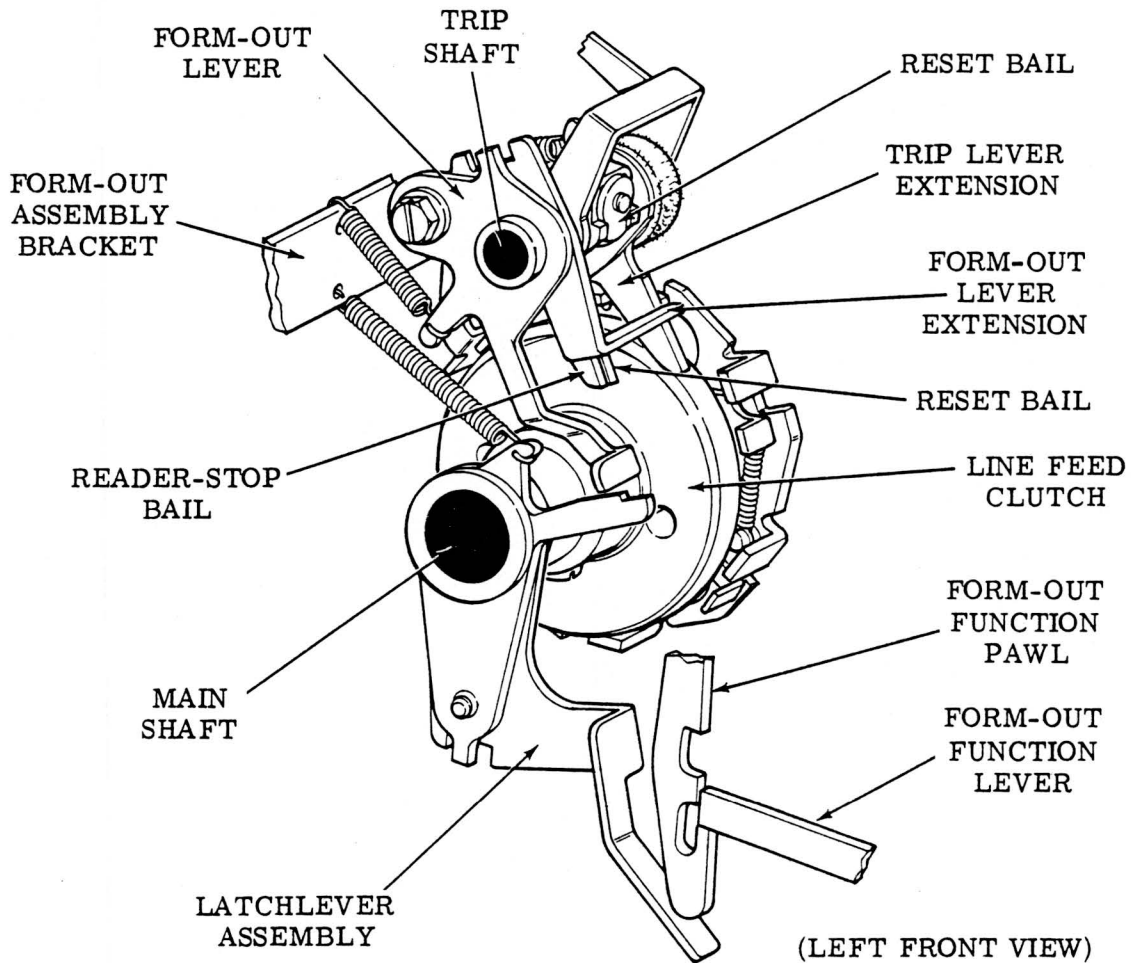

Figure 29 — Form-Out Mechanism (Sprocket Feed)

2.117 When the automatic carriage return-line feed function lever and its function pawl are pulled down during the middle portion of the cycle, the pawl encounters an extension on the carriage return function pawl and moves it down. Carriage return then occurs as described in 2.91 through 2.94.

#### ANSWER-BACK MECHANISM

##### A. General

2.118 An answer-back mechanism, illustrated in Figure 30, automatically transmits a predetermined sequence of characters for identification purposes. The basic mechanism may be actuated in two ways:

- (a) Remotely, by the reception of a predetermined call character.

(b) Locally by the depression of the HERE-IS key.

(c) In addition, as an optional feature, it may be actuated by a trip-magnet mechanism at the receipt of a signal generated by external equipment, such as a data set. The mechanism is described in the appropriate description section.

2.119 A drum is coded with characters making up the answer-back sequence. When the answer-back mechanism is actuated, it rotates the drum, which sets up the code combinations in a set of answer-back contacts. The distributor converts the positions of the contacts to start-stop signals for transmission. After the answer-back sequence has been transmitted, the answer-back mechanism returns itself to its unoperated condition. For operational considerations that

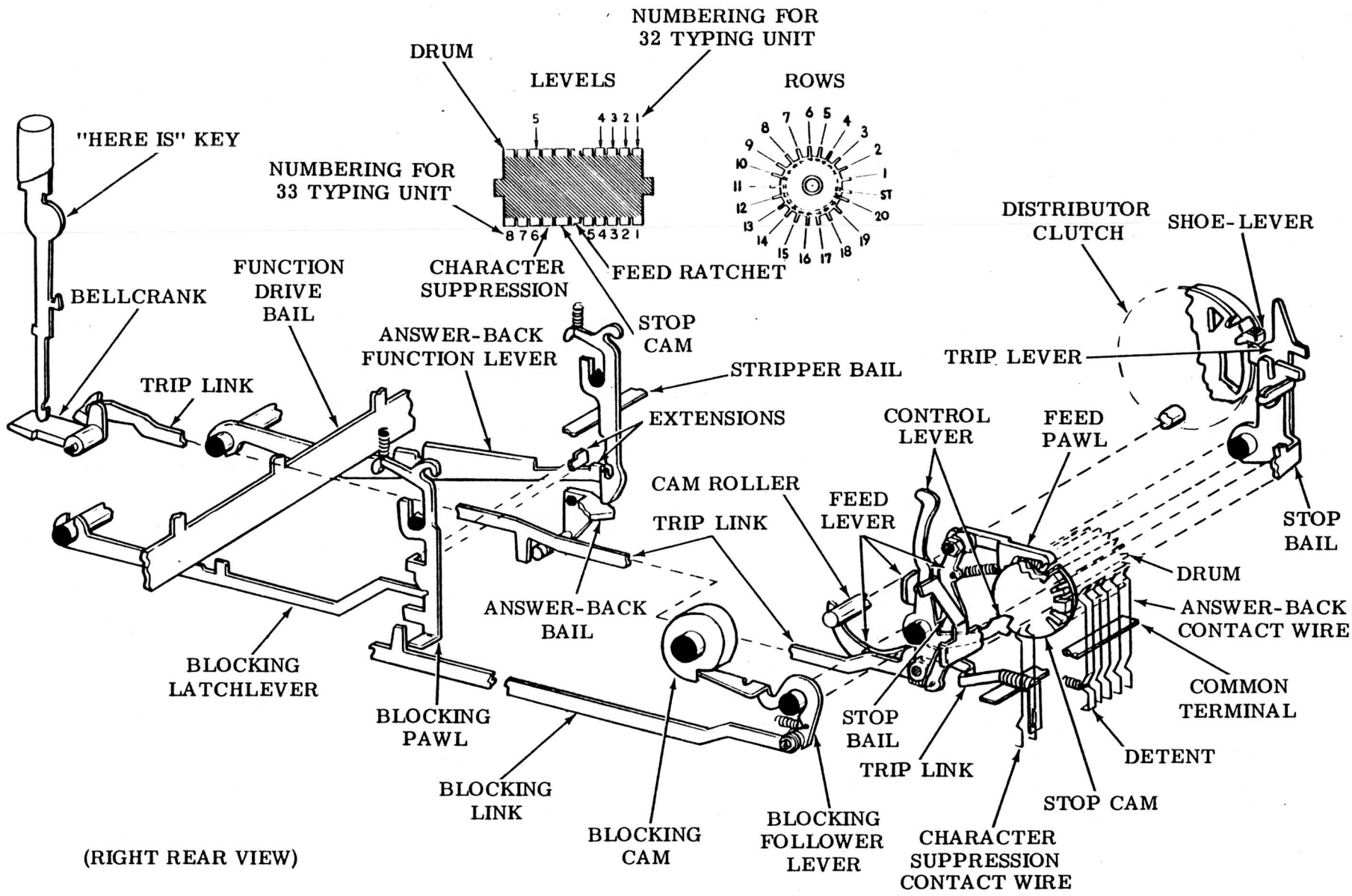

Figure 30 - Answer-Back Mechanism

(RIGHT REAR VIEW)

will be described below, provisions are made for shunting the signal line during sensing of the first answer-back character of each cycle of operation and for preventing the answer-back mechanism from being actuated by the local generation of the answer-back call character.

Note: See the appropriate installation section for further information on answer-back drum coding.

## B. Drum

2.120 Viewing it from the rear, the drum has 11 levels from right to left, as follows:

- (a) Five numbered levels.
- (b) Feed ratchet.
- (c) Stop cam.
- (d) Character suppression.
- (e) Three more numbered levels.

2.121 The numbering for 32 and 33 typing units is illustrated in Figure 30. Viewing it from the numbered end, it has 21 rows, ST (start) and 1 through 20. The feed ratchet is used to rotate the drum as described in 2.124 below. The stop cam, which has four removable tines, controls the length of the answer-back sequence, as described in 2.134 below. The character suppression level is used to shunt the first answer-back character from the signal line and delete errors as described in 2.129 through 2.130 below. By breaking off tines in the various rows at the numbered intelligence levels, the drum may be coded to generate the proper answer-back characters. For example, if the first character of an answer-back message to be transmitted by a 32 (5-level) or 33 (8-level) typing unit is the letter D code combination (1--4-) or (--3---7-), tines at either the no. 1 and 4 levels or the no. 3 and 7 levels should be broken off in the appropriate row, where the answer-back message is to start. The second character of the answer-back message would be coded into the next succeeding row.

Note 1: All answer-back messages should be preceded at least by the "carriage return" code combination and "line feed" code combination. On 32 (5-level) typing units, the answer-back message should also be preceded by the "letters" code combination.

Note 2: The 8-level code combination given for the letter D is the "even parity" code combination.

## C. Remote Actuation—Function Mechanism

2.122 The function mechanism must be arranged to actuate the mechanism upon receipt of the proper call character start-stop signal.

2.123 When the answer-back call character start-stop signal is received by the typing unit, the codebars permit the answer-back function lever to move up to its selected position, where it is latched by its function pawl. As the function lever and pawl are moved down by the function drive bail during the middle portion of the function cycle, the pawl pivots an answer-back bail, which moves a trip link frontward. The trip link pivots a control lever out of an indentation in the stop cam. The control lever, through the stop bail, moves the trip lever rearward, out of engagement with the shoe lever, and trips the distributor clutch.

2.124 When the distributor clutch begins its cycle, a cam roller moves up and permits a feed lever to pivot rearward against the control lever. A feed pawl pivoted on the feed lever is moved rearward, where it picks up the next tooth on the drum's ratchet. Near the end of the function cycle, the answer-back function pawl is stripped from its function lever by the stripper blade. The control lever, under spring pressure, tends to return to its unoperated position in the indentation of the stop cam. This would terminate the answer-back operation by disengaging the distributor clutch. However, since the feed pawl is now engaged with the next ratchet tooth, the spring pressure on the control lever is not strong enough to overcome the combined pressure of the feed lever spring and the drum's detent, and the mechanism remains in its operated condition through the first distributor cycle.

2.125 Near the end of the distributor cycle, the cam roller on the distributor clutch moves the feed lever and feed pawl frontward, and the pawl acts on the ratchet to rotate the drum one tooth. The stop cam on the drum now prevents the control lever and trip lever from returning to their stop position. The distributor clutch thus continues to cycle and rotate the answer-back drum.

2.126 The answer-back contacts are wired in parallel with the keyboard contacts to the segments of the distributor disc. As the drum is rotated during the answer-back operation, the contact wires, under spring pressure, sense each row of tines in turn. If a tine has been broken off at a given level in a row, the associated wire moves forward to its marking position against a common terminal. On the other hand, if a tine is present, it holds the spring away from the terminal in its spacing position. As the distributor clutch cycles, the distributor converts the positions of the contacts to sequential start-stop signals for transmission in the same manner as described in 2.11 through 2.16 for the keyboard contacts.

2.127 The drum continues to rotate until the next indentation in the stop cam is presented to the control lever. The latter then moves into the indentation and returns the associated parts to their unoperated position. The shoe lever then strikes the trip lever and disengages the distributor clutch. The mechanism is thus returned to its unoperated condition.

#### D. Local Actuation—HERE IS Key

2.128 When the HERE IS key is manually depressed, it pivots a bellcrank, which moves the trip link forward. The trip link pivots the control lever to its operated position, and the answer-back operation is the same as that described in 2.122 through 2.127 above.

#### E. First Character Suppression

2.129 Since the answer-back, keyboard, and tape reader (where used) contacts are wired in parallel with the distributor disc, the answer-back contacts must all be in their spacing position when the mechanism is unoperated, so that they do not interfere with keyboard or tape reader transmission. Therefore, inasmuch as the answer-back feed mechanism does not feed the drum until near the end of the first cycle, the first character sensed should be all spacing to prevent garbling of the regular message sent from the keyboard and/or tape reader. However, an all "spacing" character is undesirable in some systems. Therefore, a way is provided for shunting transmission from the signal line during the sensing of the first answer-back character.

2.130 As described in 2.123 above, the trip link moves forward when an answer-back sequence is initiated and remains there until it is terminated. In this position, it permits a character suppression contact wire to sense the drum's character-suppression level. The character-suppression contact is wired so that it shunts transmission from the outgoing signal line when it is closed. The tine at the character-suppression level of the first character of each cycle of an answer-back sequence must always be broken off in order to accomplish this. Thus the character-suppression contact wire is selected and keeps the line marking until the second character is sensed. The tines are left in the character-suppression level in other rows, except for certain conditions, such as to correct coding errors or to vary the message length. This allows, in effect, a one-character delay before the message coded into the answer-back drum is transmitted. At the end of the operation, the trip link again moves rearward and holds the wire unselected, while the mechanism is unoperated.

#### F. Answer-Back Suppression on Transmission

2.131 Since the typing unit receives every code combination that it transmits, the sending of the answer-back call character would actuate the local answer-back mechanism as well as the one at the distant station. To prevent this, a blocking mechanism is provided which prevents the function mechanism from operating in the answer-back area during transmission.

2.132 As the distributor clutch cycles, a blocking cam pivots a blocking follower lever which pulls a blocking link rearward. The link pivots a blocking pawl rearward until it releases a blocking latchlever which, under spring pressure, moves up against the function drive bail. When the function drive bail and the blocking latchlever move up during the first part of the function cycle, the blocking latchlever cams the blocking pawl further rearward where an extension on the pawl is over an extension on the answer-back function lever. The function lever is thus prevented from moving up far enough to be latched by its pawl and initiate the answer-back sequence.

2.133 During the latter part of the distributor cycle, the blocking cam allows the blocking link to move forward to its unoperated position. As the function drive bail moves down during the middle portion of the function cycle,

it drives the blocking latchlever downward to the point where the blocking pawl is permitted to pivot frontward to its unoperated position. Thus every time a character is initiated locally, the distributor clutch cycles and operates the blocking mechanism which prevents the answer-back function lever from sensing the codebars and initiating the answer-back sequence regardless of what character is processed by the typing unit. On the other hand, when remotely initiated characters are received, the distributor clutch does not cycle, the blocking mechanism is not operated, and the function lever is permitted to sense the codebars and initiate the answer-back sequence upon receipt of the predetermined call-character signal.

#### G. Length of Answer-Back Sequence

2.134 The length of the answer-back sequence can be varied either by altering the stop-cam level or the character-suppression level.

- (a) Stop cam: The answer-back mechanism can be coded for either 1-, 2-, or 3-cycle operation by removing the appropriate tine(s) from the stop-cam level. In 1-cycle operation, the stop cam in row "6" is removed. This coding yields a maximum of 20 rows which are available for coding different characters into the answer-back drum. There are actually 21 rows on the answer-back drum, but only 20 rows can be used for coding since one row (2.130) is suppressed. The number of rows available for message coding is summarized below for 1-, 2-, or 3-cycle operation:

<u>Cycle Operation</u>	<u>Actual Rows</u>	<u>Available Rows</u>
1	21	20
2	10(11)*	9(10)*
3	7	6

\*Alternately one, then the other.

When multiple-cycle operation is employed, the answer-back sequence must be coded in each segment of the answer-back drum so that the same message will be transmitted each time the answer-back mechanism is initiated.

- (b) Character Suppression: Quite often, due to message length, messages coded into the answer-back drum do not require the use of every available row for coding. Unneeded rows are eliminated from the message transmission by removing the unneeded character suppression tine(s). The answer-back drum will stop through its complete cycle, but the transmission of the coded characters from the unneeded rows will be shunted from the signal line.

Note: The character-suppression tine in the last row of a cycle should not be removed on 33 typing units used in systems where a response to each answer-back actuation signal must always be obtained. If the tine is removed, the answer-back mechanism will not respond to consecutive answer-back actuation signals. This is due to the operating characteristics of the typing unit which, when the character-suppression tine in the last row of a cycle is removed, leaves the answer-back blocking panel blocking at the end of the answer-back drum cycle of operation. The answer-back blocking pawl will remain blocking until after another character is received through the selector mechanism. The subsequently received character causes the function mechanism to reset the answer-back blocking pawl to its unblocking position. After being reset and upon receipt of an answer-back actuation signal, the answer-back mechanism will be triggered. Hence, with the character-suppression tine removed from the last row of an answer-back cycle, typing unit answer-back mechanisms will only respond to every other answer-back actuation signal unless an intervening character is received through the selector mechanism.

32 AND 33 TYPING UNIT

LUBRICATION

CONTENTS	PAGE	CONTENTS	PAGE
1. GENERAL . . . . .	1	Stop bail . . . . .	4
2. BASIC UNITS . . . . .	2	Trip lever . . . . .	3
COMMON MECHANISMS . . . . .	2	Trip shaft . . . . .	5
Armature . . . . .	7	Typewheel mechanism . . . . .	15
Automatic codebar . . . . .	8	FRICITION FEED MECHANISMS . . . . .	18
Blocking levers . . . . .	8	Line feed mechanism . . . . .	19
Carriage area . . . . .	13	Paper feed area . . . . .	18
Carriage return and spacing levers . . . . .	11	Platen . . . . .	18
Codebars . . . . .	9	SPROCKET FEED MECHANISMS . . . . .	19
Codebar clutch . . . . .	5	Cam, pulley, and gear combination . . . . .	21
Dashpot . . . . .	13	Form-out mechanism . . . . .	22
Disc and brushes . . . . .	3	Line feed clutch . . . . .	22
Distributor area . . . . .	2	Paper feed area . . . . .	19
Drive mechanism . . . . .	12	Platen mechanism . . . . .	20
Function area . . . . .	8	Platen drive area . . . . .	21
Function clutch . . . . .	5	3. VARIATIONS TO BASIC UNITS . . . . .	23
Function levers . . . . .	10	Answer-back area . . . . .	23
Intermediate gears . . . . .	17	Answer-back mechanism . . . . .	24
Latchlever . . . . .	3	Trip magnet . . . . .	23
Latchlever and trip lever . . . . .	6	1. GENERAL	
Main shaft area . . . . .	4	1.01 This section is issued to provide in-	
Motor . . . . .	17	structions for lubricating the 32 and 33	
Motor area . . . . .	17	typing unit and to present the lubricating in-	
Print hammer . . . . .	14	structions as a separate section.	
Push levers and stripper ball . . . . .	7	1.02 The general lubrication areas are illus-	
Reset arm . . . . .	14	trated by photographs. The specific	
Reset bail . . . . .	9	points to receive lubricant are indicated on	
Ribbon guide spring . . . . .	15	line drawings with appropriate textual instruc-	
Ribbon mechanism . . . . .	16	tions. Line drawings and textual instructions	
Rocker and pawls . . . . .	9	follow each photograph and are keyed to the	
Selector area . . . . .	6	photograph by paragraph numbers.	
Selector clutch . . . . .	6		
Selector levers . . . . .	7		
Slides . . . . .	16		
Slide guide plates - 1 . . . . .	14		
Slide guide plates - 2 . . . . .	15		
Spacing area . . . . .	10		
Space bellcrank . . . . .	10		
Spacing mechanism - 1 . . . . .	11		
Spacing mechanism - 2 . . . . .	12		

SECTION 574-122-701

1.03 Thoroughly lubricate the typing unit, but avoid over lubrication that might permit the lubricant to drip or be thrown onto adjacent parts. Saturate all felt washers and oilers with oil, and apply oil to each end of all bearings. Use KS7470 Oil where oil is required and KS7471 Grease where grease is required.

1.04 Lubricate the typing unit before placing it into service or prior to storage. After a short period of service, relubricate it to make sure no areas have been missed. Thereafter, lubricate the typing unit at regular intervals as indicated below:

<u>Operating Speed</u> (Words per Minute)	<u>Lubrication Interval</u>
60 or 66	1000 hr* or 1 yr**
100	500 hr* or 6 mo**

\*Station Set operating hours.

\*\*Whichever comes first.

1.05 The textual instructions that accompany the line drawings consist of abbreviated directions, specific lubrication points, and parts affected. The meanings of the abbreviated directions (symbols) follow:

<u>Symbol</u>	<u>Meaning</u>
D	Keep dry - no lubricant permitted
G	Apply thin coat of KS7471 Grease

<u>Symbol</u>	<u>Meaning</u>
GOL	Brush on well a mixture of 50% KS7471 Grease and 50% KS7470 Oil
OL	Oil liberally (3 or more drops)
OS	Oil sparingly (1 or 2 drops only)
OSAT	Saturate with oil (felt washers and oilers)
OSD	Oil sparingly or leave dry**
OSL	Oil sparingly or liberally

\*\*Applies to all areas not contacted by other parts.

1.06 References to "left," "right," "front," or "rear," etc consider the typing unit to be viewed from a position where the carriage area faces up and the selector area is located to the viewer's left.

**CAUTION:** DO NOT USE ALCOHOL, MINERAL SPIRITS, OR OTHER SOLVENTS TO CLEAN PLASTIC PARTS OR PARTS WITH PROTECTIVE-DECORATIVE FINISHES. NORMALLY, A SOFT, DRY CLOTH SHOULD BE USED TO REMOVE DUST, OIL, GREASE, OR OTHERWISE CLEAN PARTS OR SUBASSEMBLIES. IF NECESSARY, A SOFT CLOTH DAMPENED WITH SOAP OR MILD DETERGENT MAY BE USED. AFTERWARDS, RINSE EACH CLEANED PART OR SUBASSEMBLY WITH SOFT, DAMP CLOTH AND BUFF WITH A SOFT, DRY CLOTH.

2. BASIC UNITS

COMMON MECHANISMS

2.01 Distributor Area

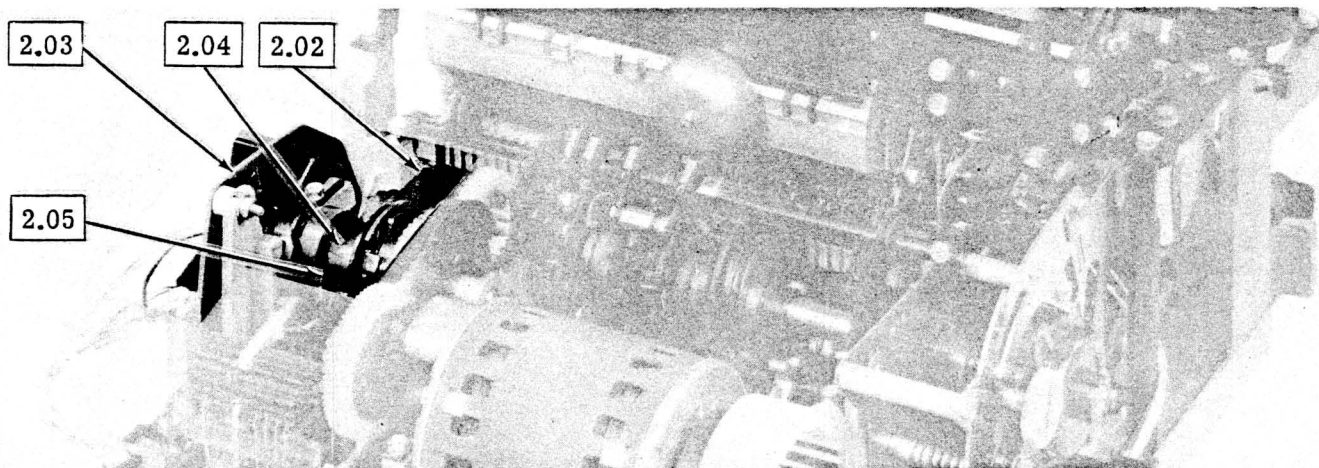

(LEFT REAR VIEW)

2.02 Trip Lever

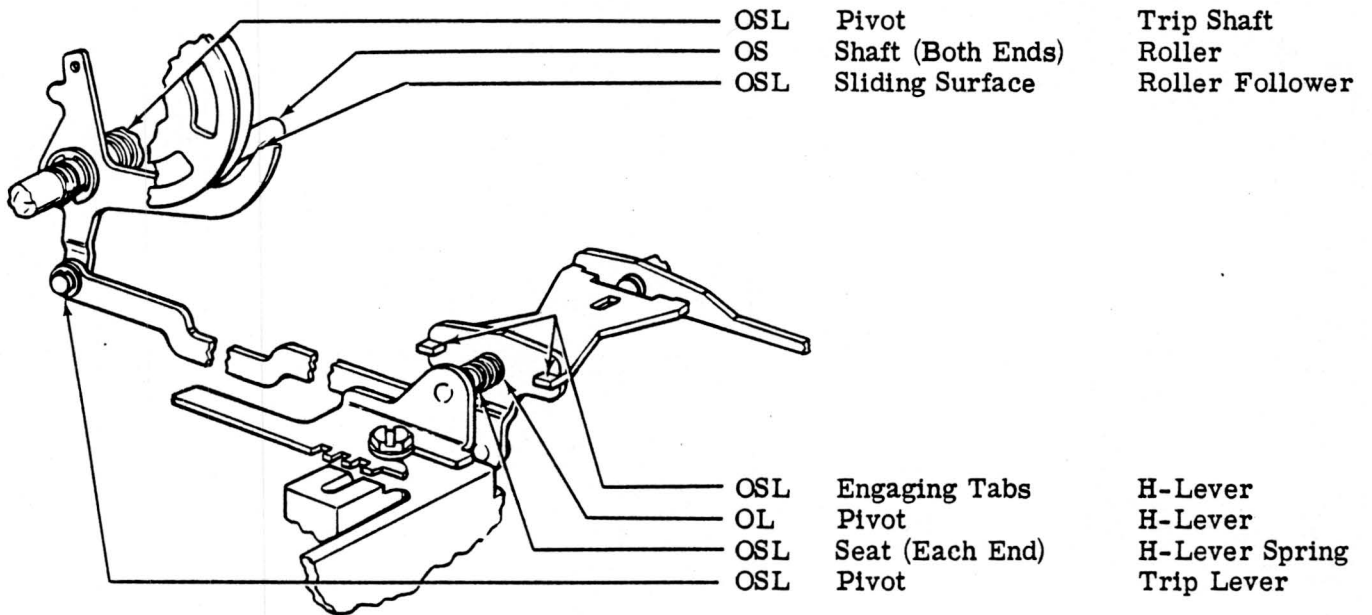

(LEFT FRONT VIEW)

2.03 Disc and Brushes

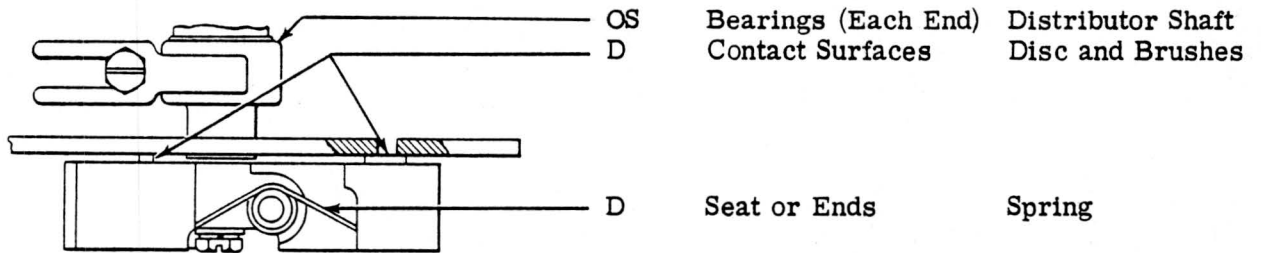

(TOP VIEW)

2.04 Latchlever

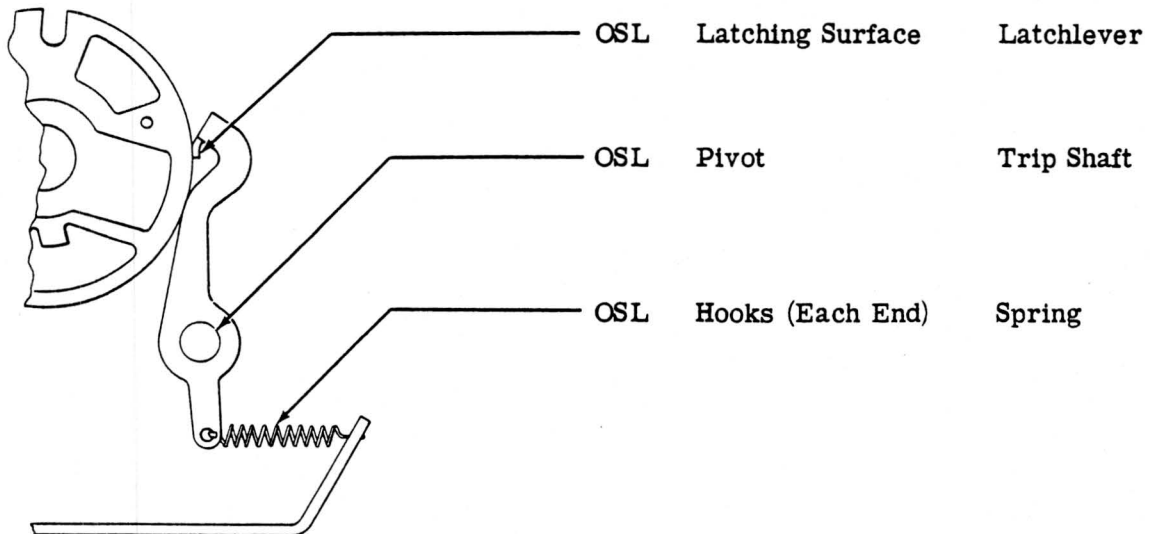

(RIGHT SIDE VIEW)

2.05 Stop Bail

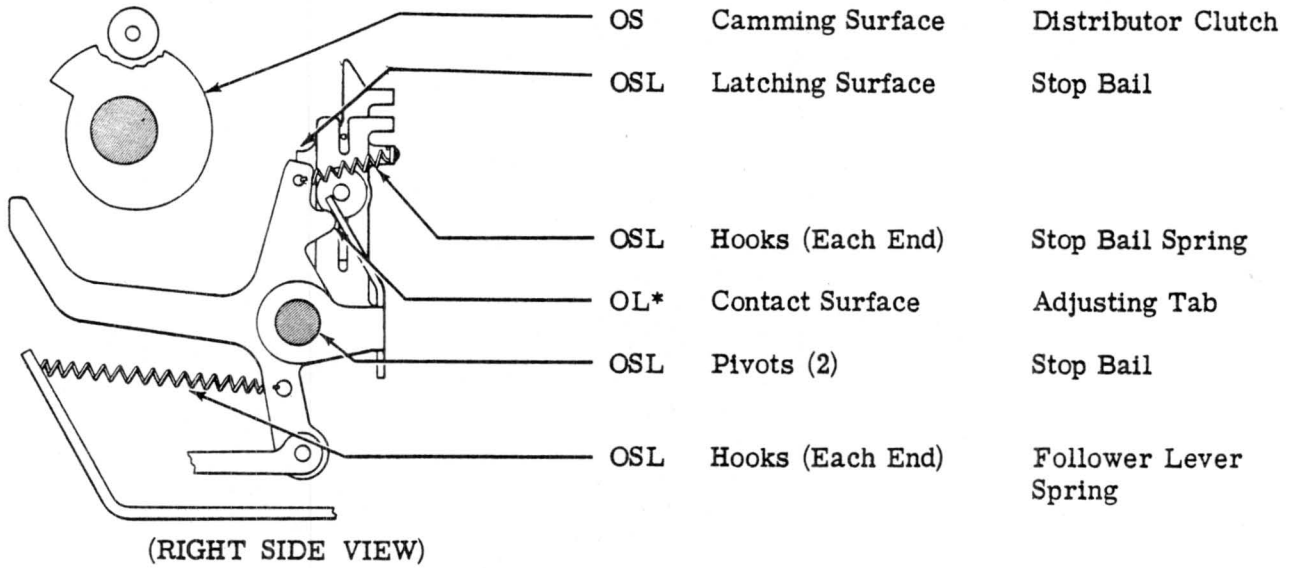

\*GOL when assembly is overhauled.

2.06 Main Shaft Area

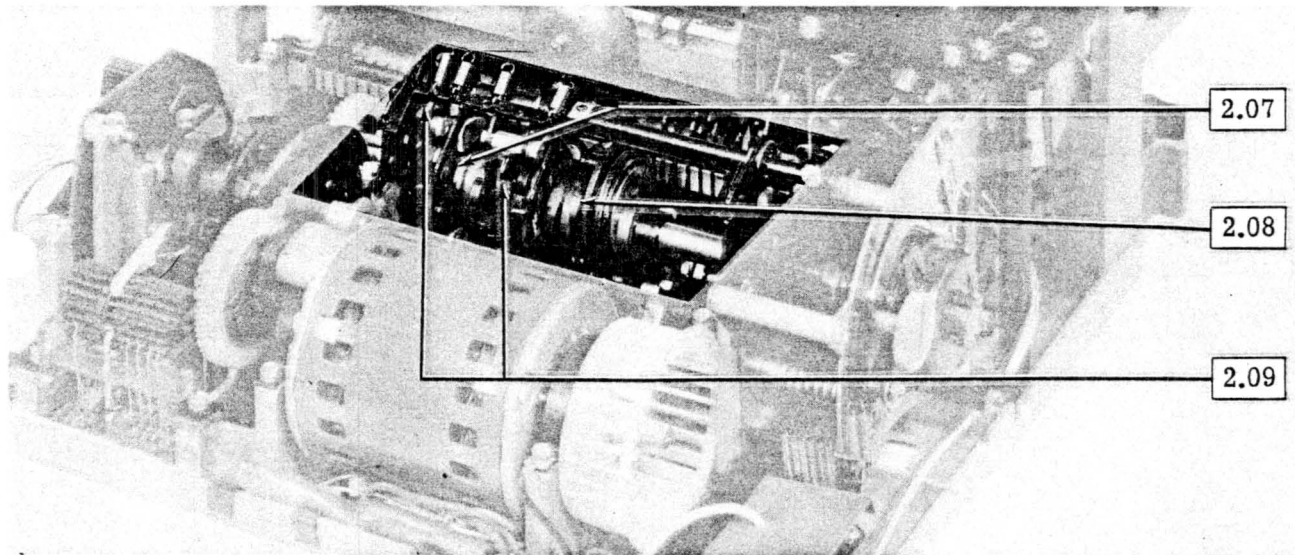

(LEFT REAR VIEW)

2.07 Codebar Clutch

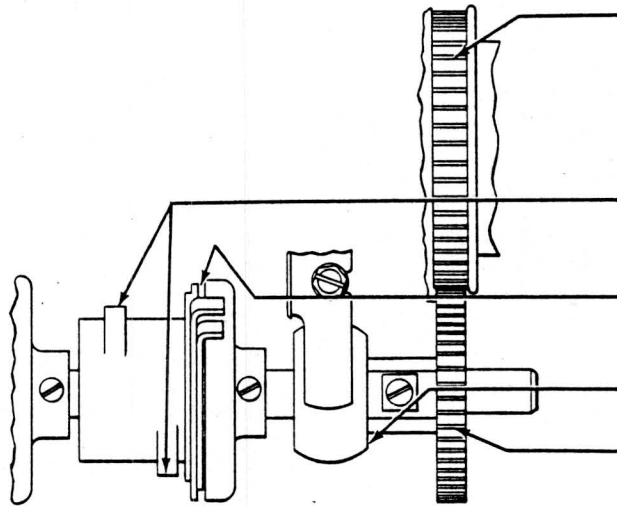

- G Teeth Distributor Gear  
(Do not grease teeth of motor belt sprocket)
- OL\* Camming Surfaces Eccentric Cams
- OSD Interior Mechanism All Clutches
- OS Bearings (Both Ends) Main Shaft
- G Teeth Gear

(TOP VIEW)

2.08 Function Clutch

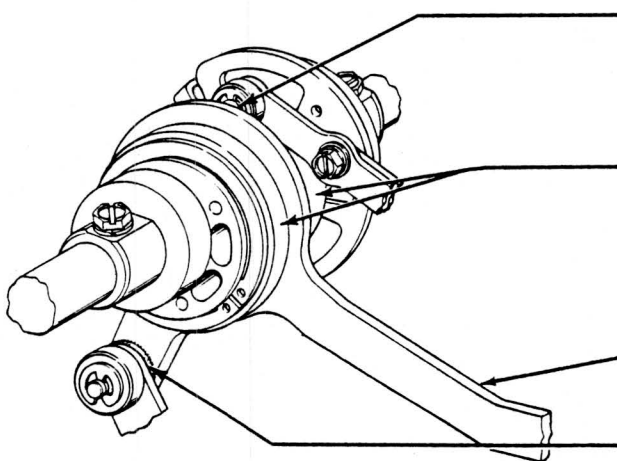

- OS Shaft (Each End) Roller
- OL\* Camming Surfaces Eccentric Cams
- OSL Sliding Surface Carriage Drive Arm
- OSAT Felt Washer Function Drive Arm

(LEFT FRONT VIEW)

2.09 Trip Shaft

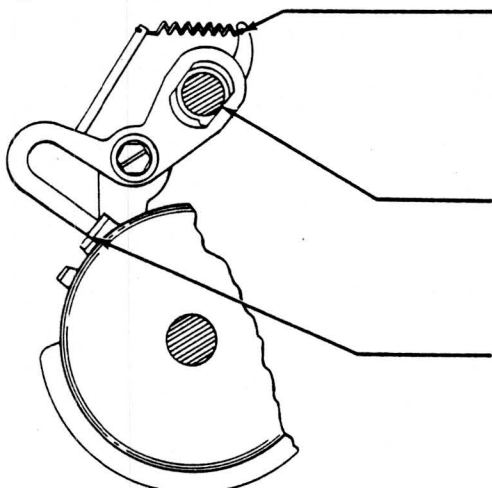

- OSL Hooks (Each End) Springs (4)
- OL\* Pivot Bearings Shaft (6 Points)
- OSL Latching Surface Trip Lever (2)

(LEFT SIDE VIEW)

\*GOL when assembly is overhauled.

2.10 Selector Area

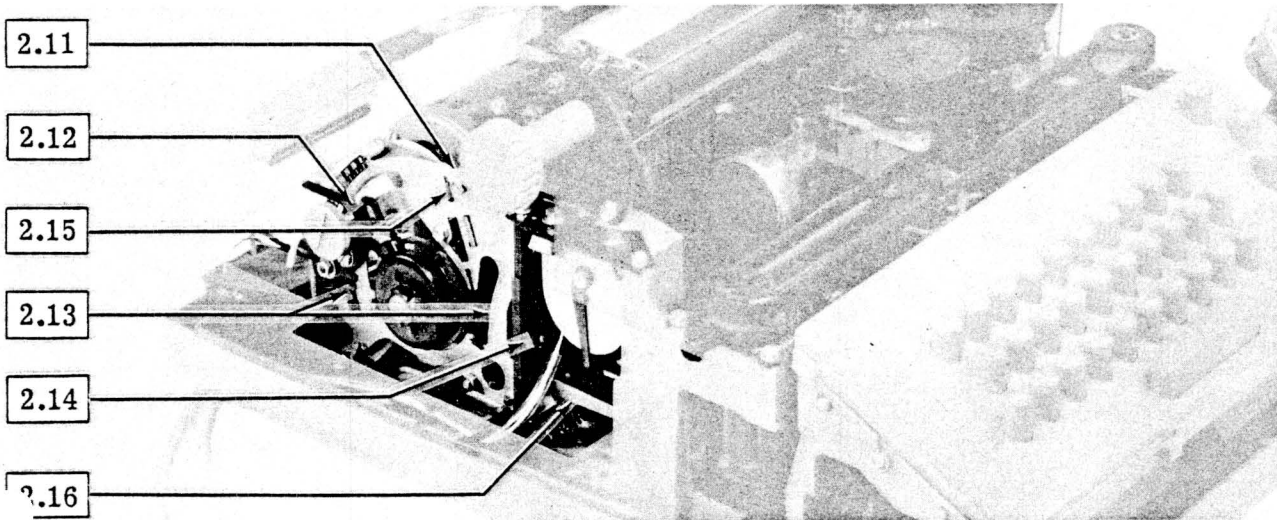

(LEFT SIDE VIEW)

2.11 Selector Clutch

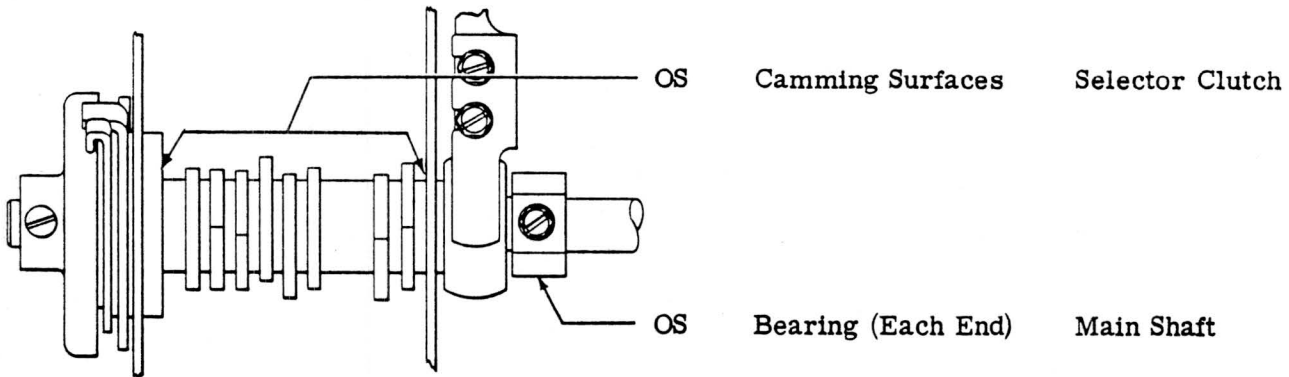

(TOP VIEW)

2.12 Latchlever and Trip Lever

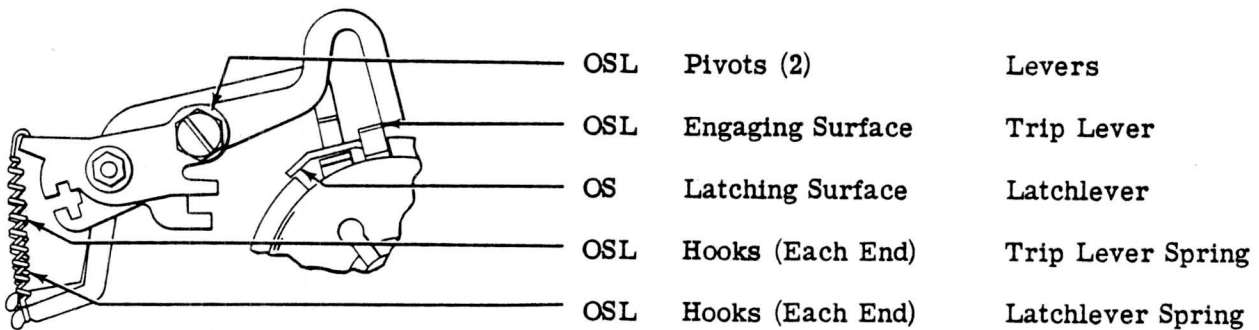

(LEFT SIDE VIEW)

2.13 Selector Levers

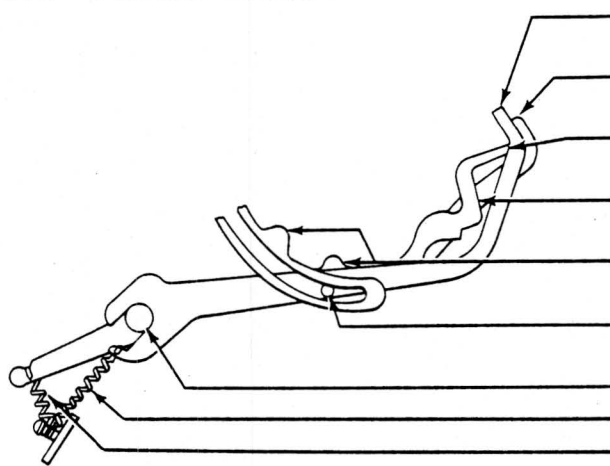

G	(After Oiling) Tip	Start Lever
OS	Contact Surface	Locklever
OS	Contact Surface	Selector Levers (6)
OSL	Engaging Surface	Selector Levers (6)
OL*	Camming Surface	Selector Levers (6)
OSL	Sliding Contact	Start Lever
OSL	Pivots (8)	Levers
OSL	Hooks (Each End)	Start Lever Spring
OSL	Hooks (Each End)	Springs (6)

(LEFT SIDE VIEW)

2.14 Push Levers and Stripper Bail

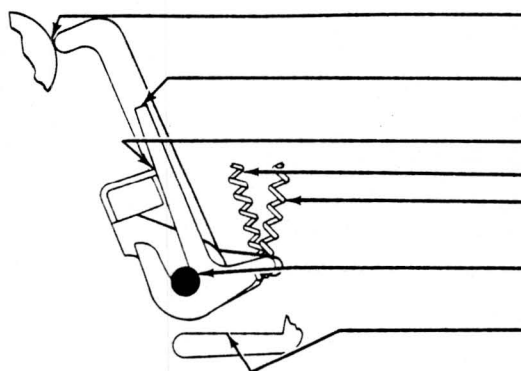

OL*	Camming Surface	Cam Follower
OSL	Latching Surface	Push Levers (6)
OSL	Contact Surface	Stripper Bail
OSL	Hooks (Each End)	Bail Spring
OSL	Hooks (Each End)	Push Lever Springs (6)
OSL	Pivots (6)	Push Levers
OSL	Contact Surfaces	Blocking Levers (6)

(LEFT SIDE VIEW)

2.15 Armature

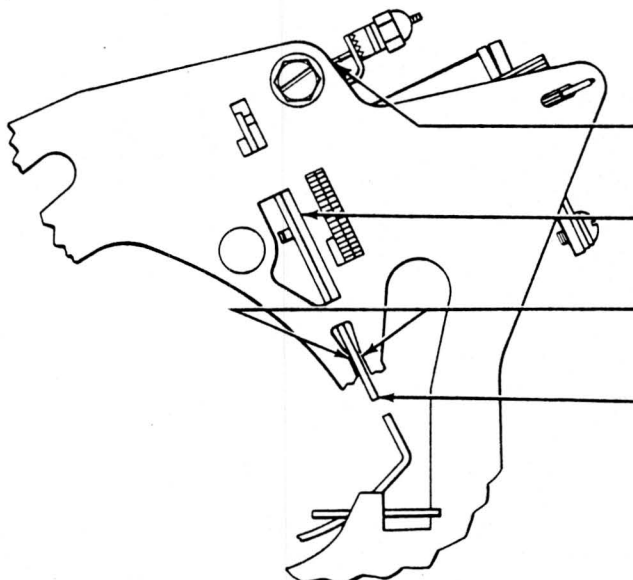

D	Hooks	Armature Spring
D	Engaging Surfaces	Armature
OSD	Engaging Surfaces	Side Plates
G	Engaging Surface	Armature

(LEFT SIDE VIEW)

\*GOL when assembly is overhauled.

2.16 Blocking Levers

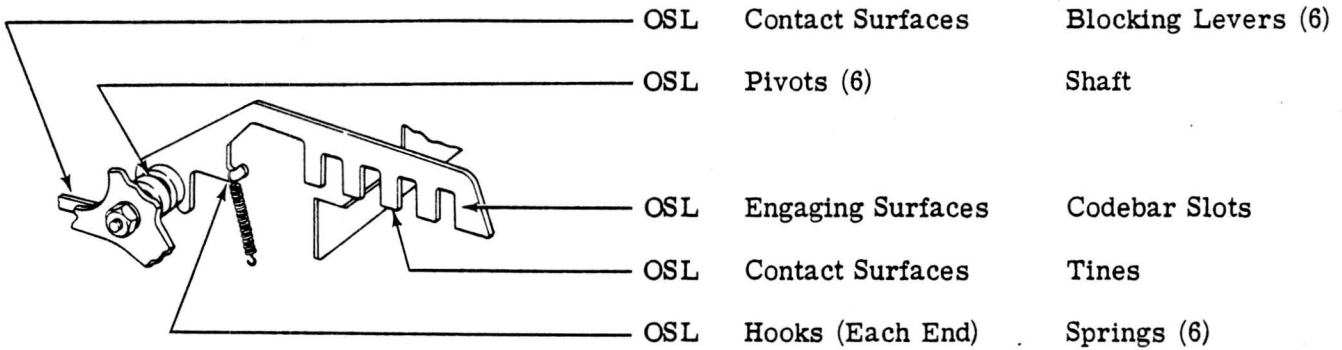

(LEFT FRONT VIEW)

2.17 Function Area

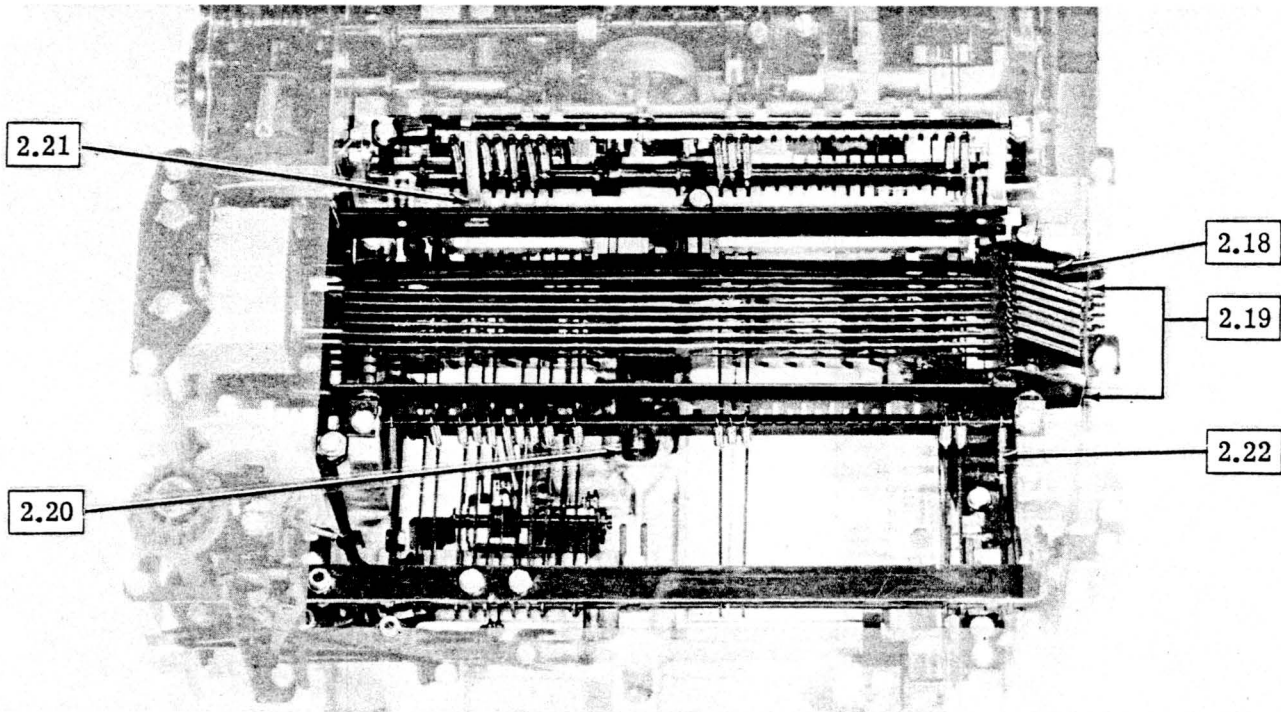

(TOP VIEW)

(Platen and carriage removed for illustration purposes.  
 Removal for lubrication is not required.)

2.18 Automatic Codebar

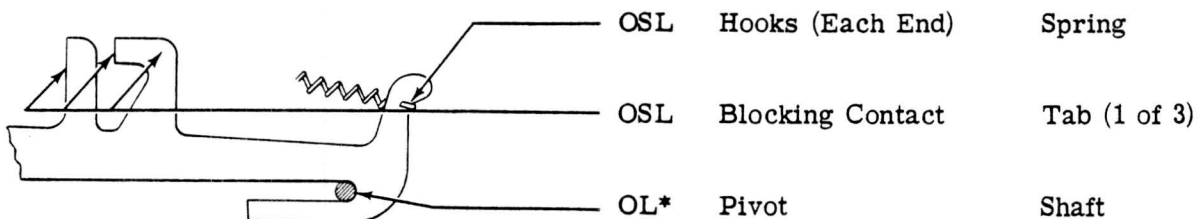

(FRONT VIEW)

\*GOL when assembly is overhauled.

2.19 Codebars

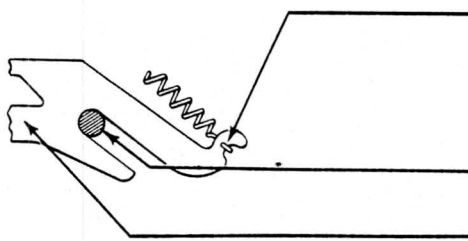

(FRONT VIEW)

- OSL Hooks (Each End) Springs (7)
- OL\* Pivots (7) Shaft
- D Area Between Codebars

\*GOL when assembly is overhauled.

2.20 Reset Bail

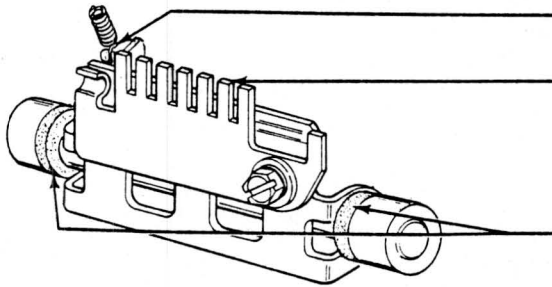

(LEFT FRONT VIEW)

- OSL Hooks (Each End) Spring
- OSL Contact Surfaces Codebar Engaging Tines
- OSAT Felt Washers (2) Reset Bail Shaft

2.21 Rocker and Pawls

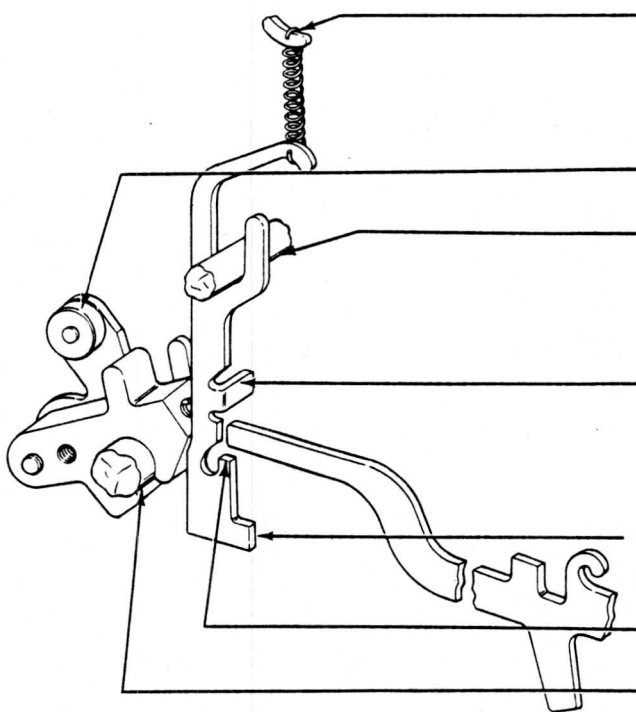

(LEFT FRONT VIEW)

- OSL Hooks (Each End) Pawl Springs
- OSL Pivot Rocker Arm
- OSL Pivots (11) Shaft
- OSL Latching Surfaces Pawls
- OSL Engaging Surfaces Pawls
- OSL Engaging Surfaces Function Levers
- OS Bearings and Pivots (Each End - 4) Function Shaft

2.22 Function Levers

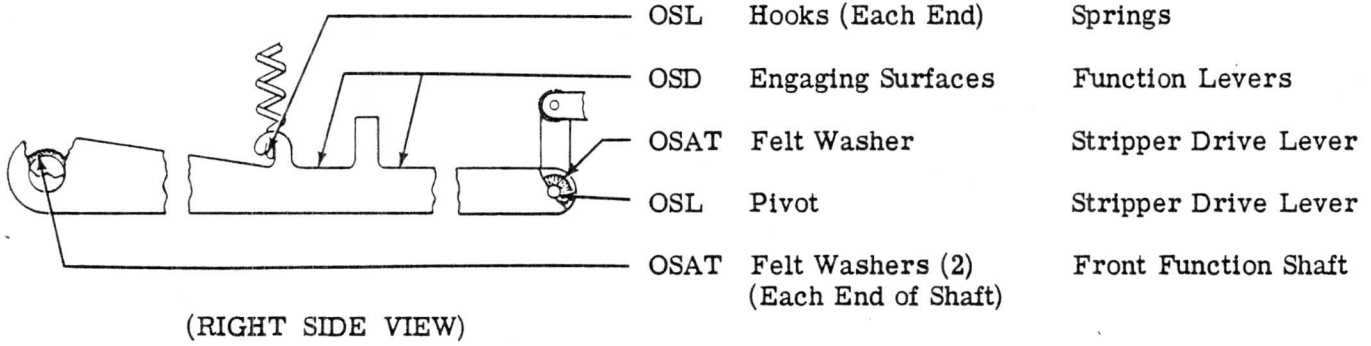

2.23 Spacing Area

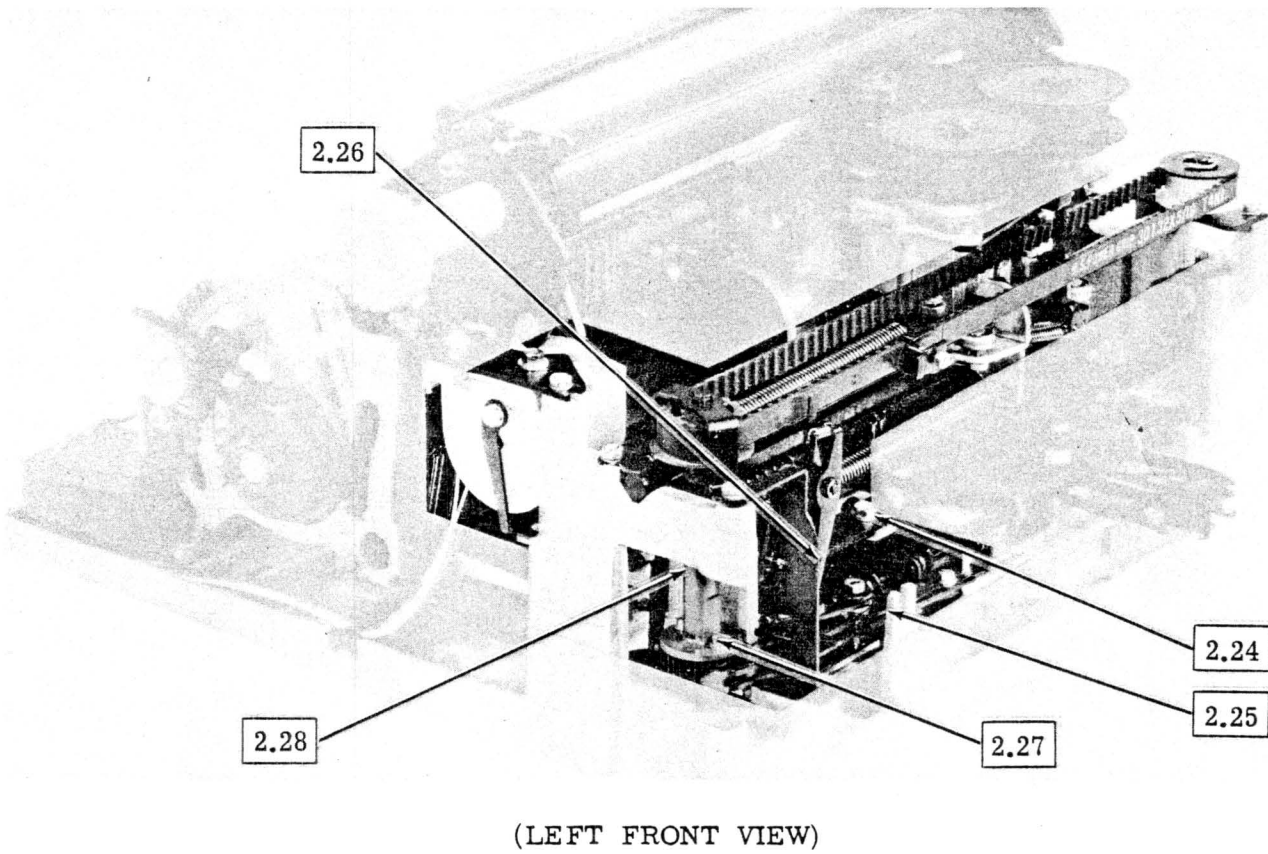

2.24 Space Bellcrank

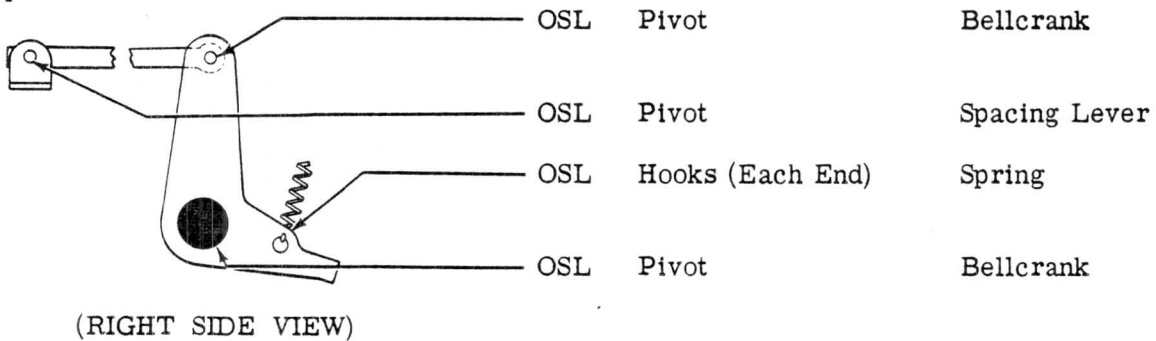

2.25 Carriage Return and Spacing Levers

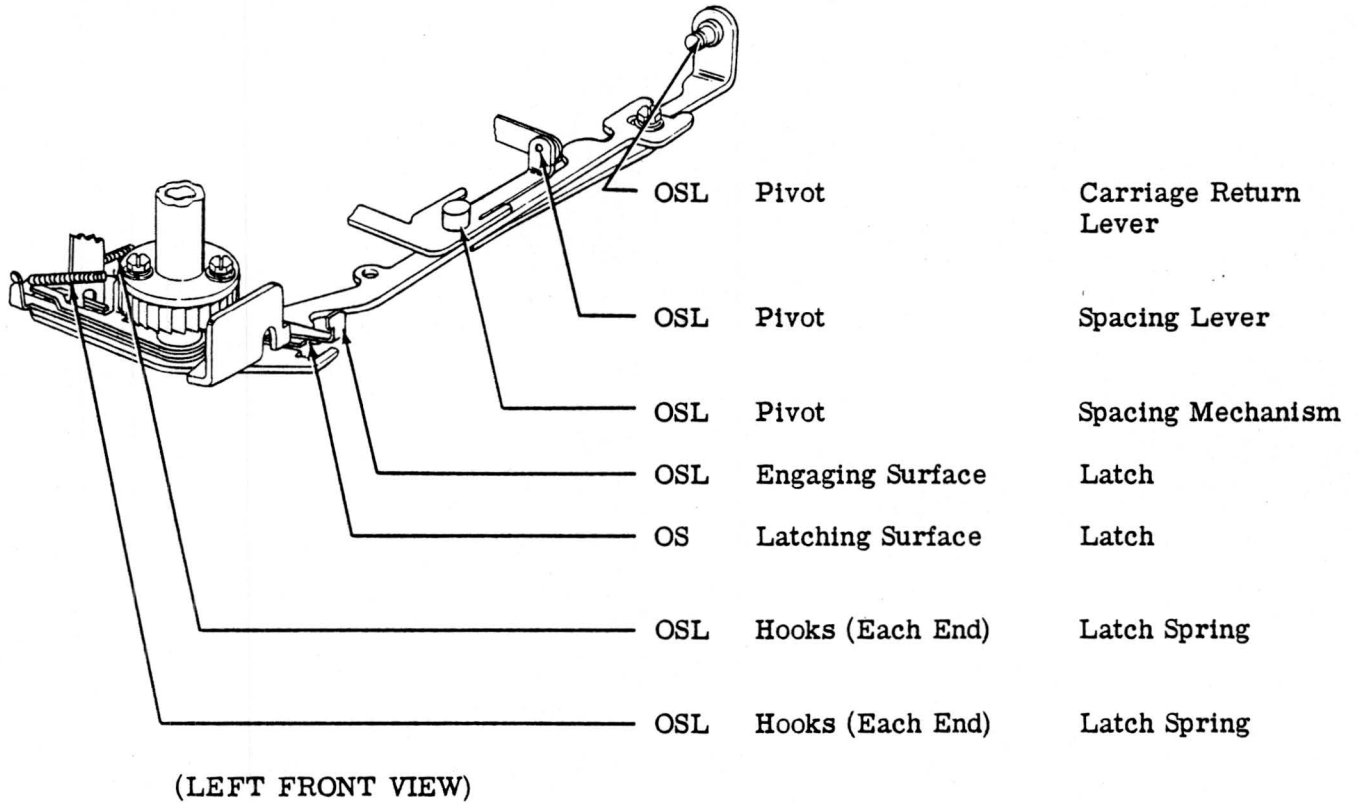

2.26 Spacing Mechanism - 1

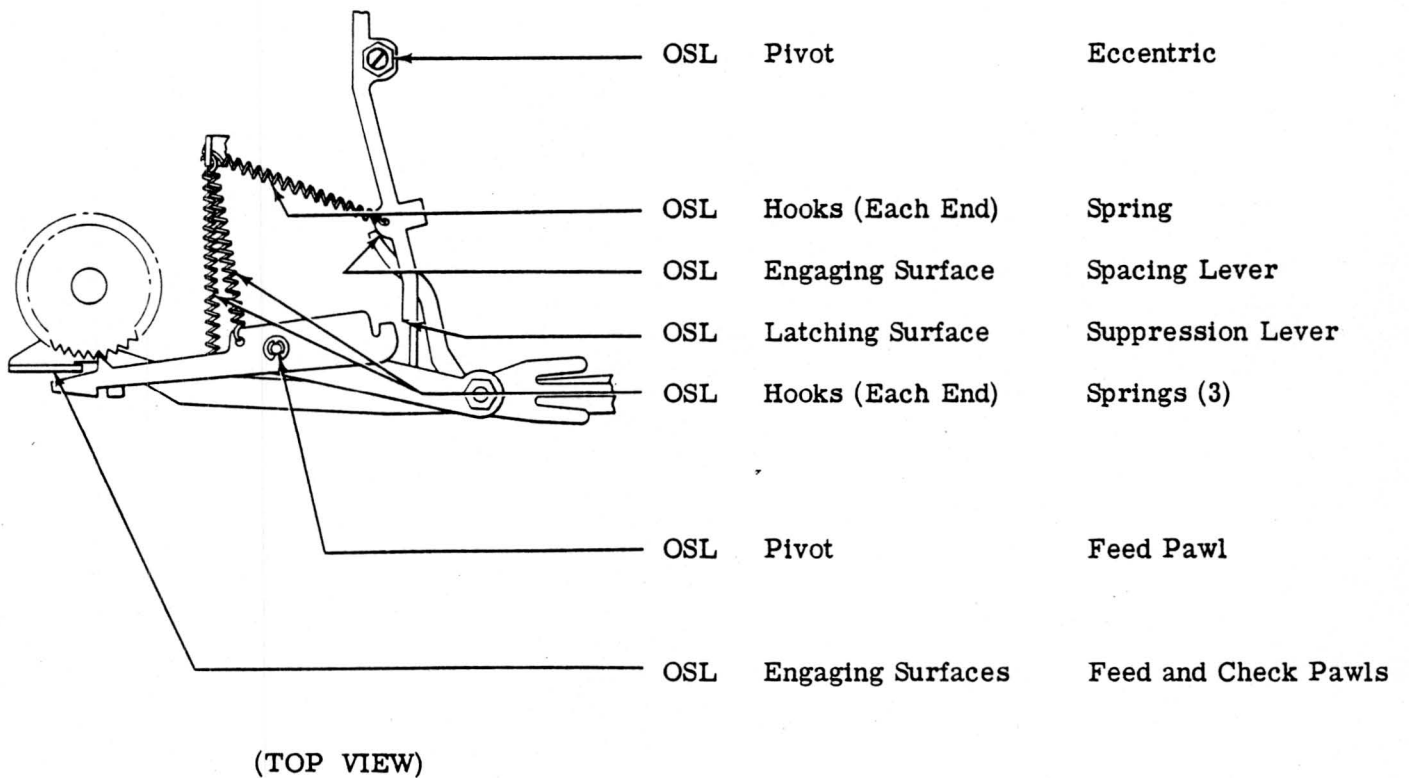

2.27 Drive Mechanism

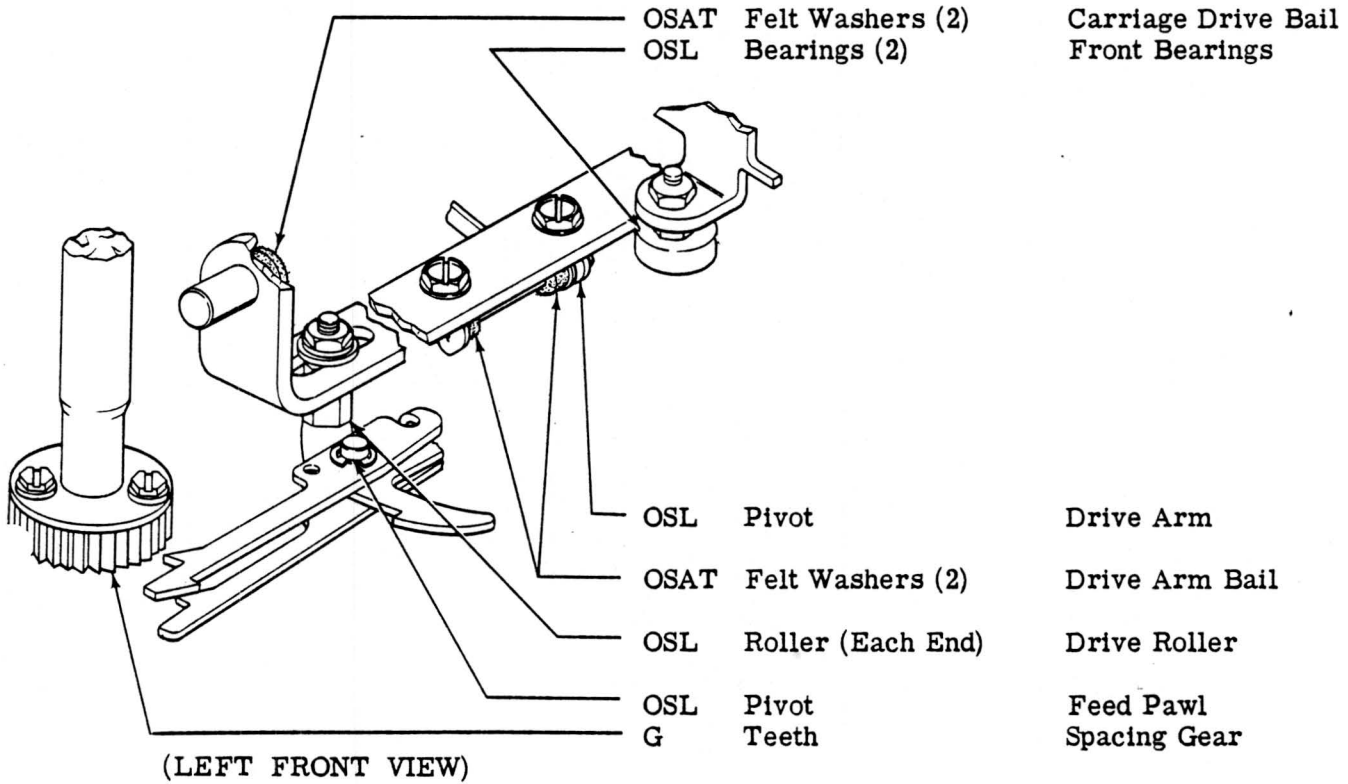

2.28 Spacing Mechanism - 2

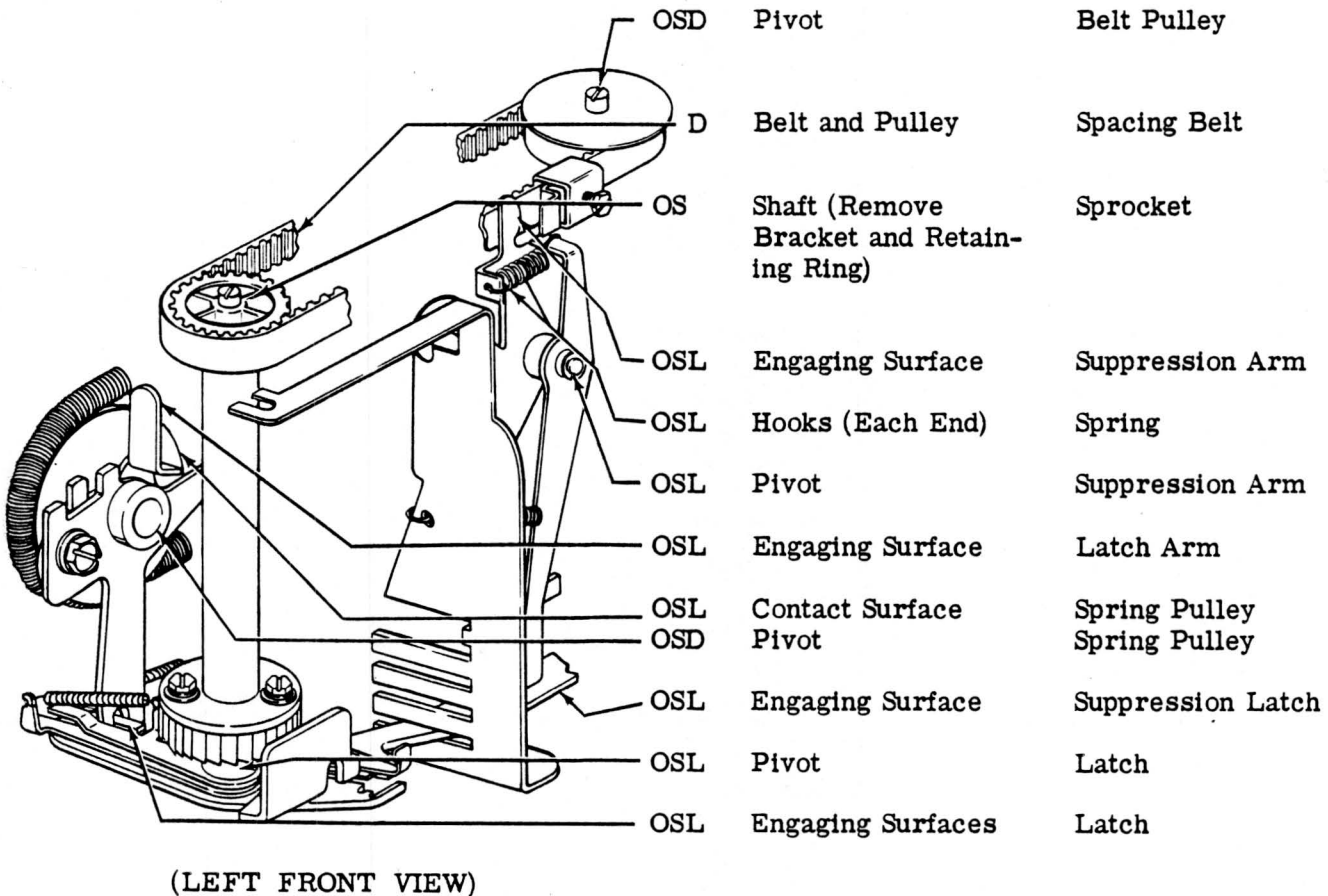

2.29 Carriage Area

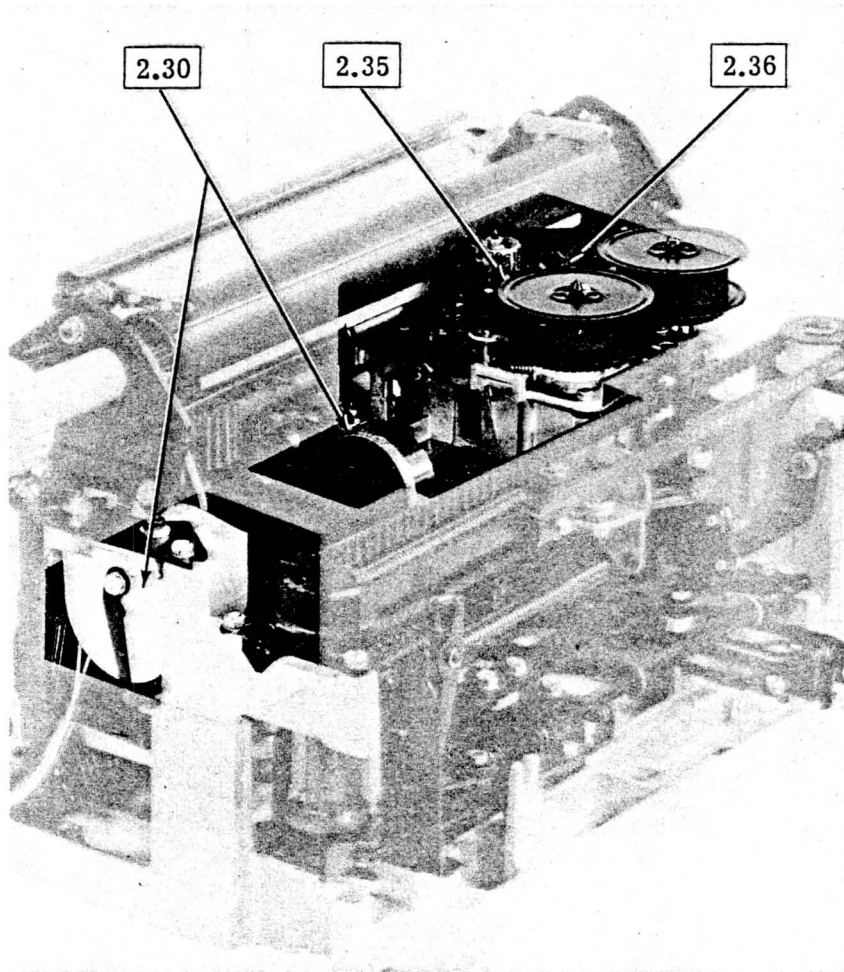

(LEFT FRONT VIEW)

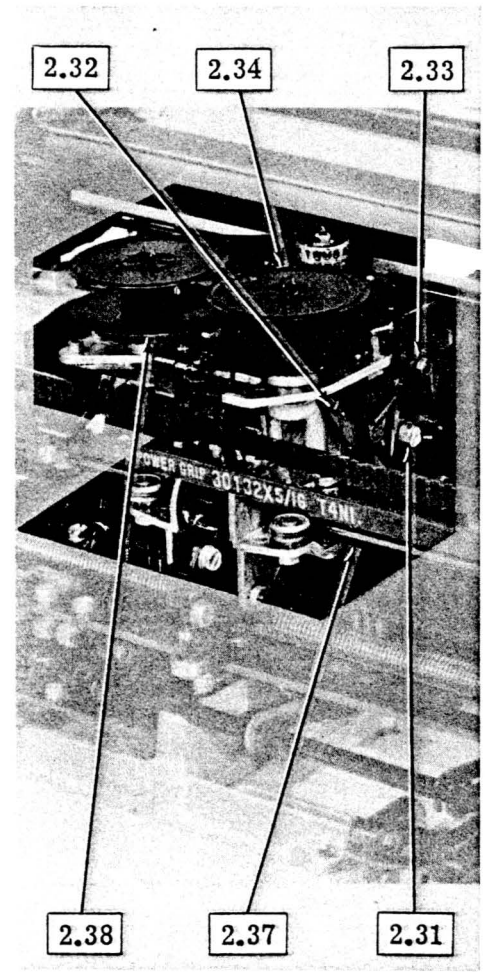

(RIGHT FRONT VIEW)

Note: Remove ribbon mechanism before lubricating. For instructions, see the appropriate typing unit section.

2.30 Dashpot

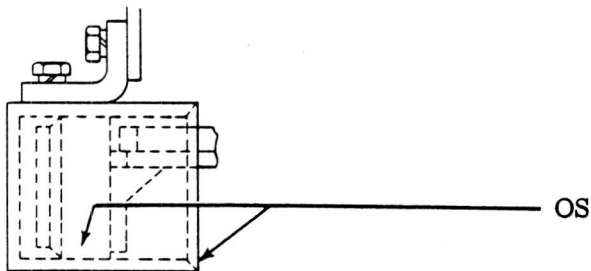

(FRONT VIEW)

Sliding Surfaces      Dashpot and Cylinder  
 (Apply with oil dampened cloth. Too much lubricant will cause malfunction.)

2.31 Print Hammer

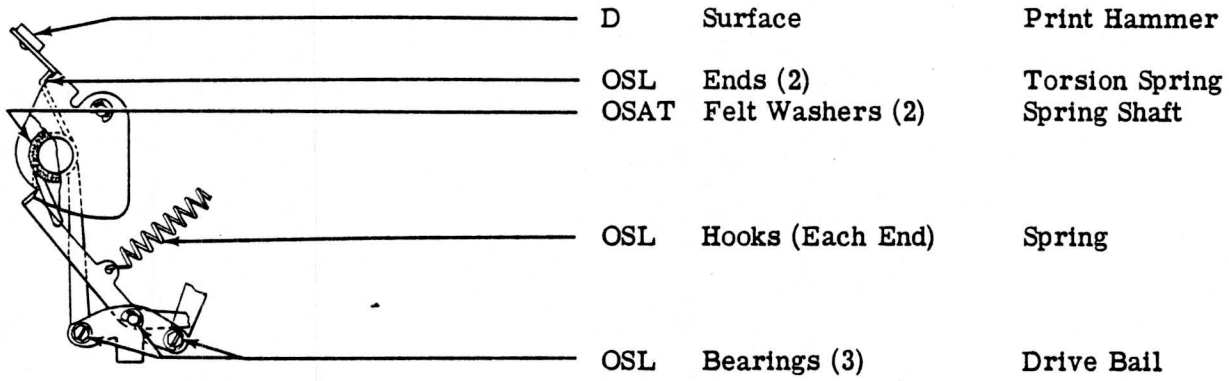

(RIGHT SIDE VIEW)

2.32 Reset Arm

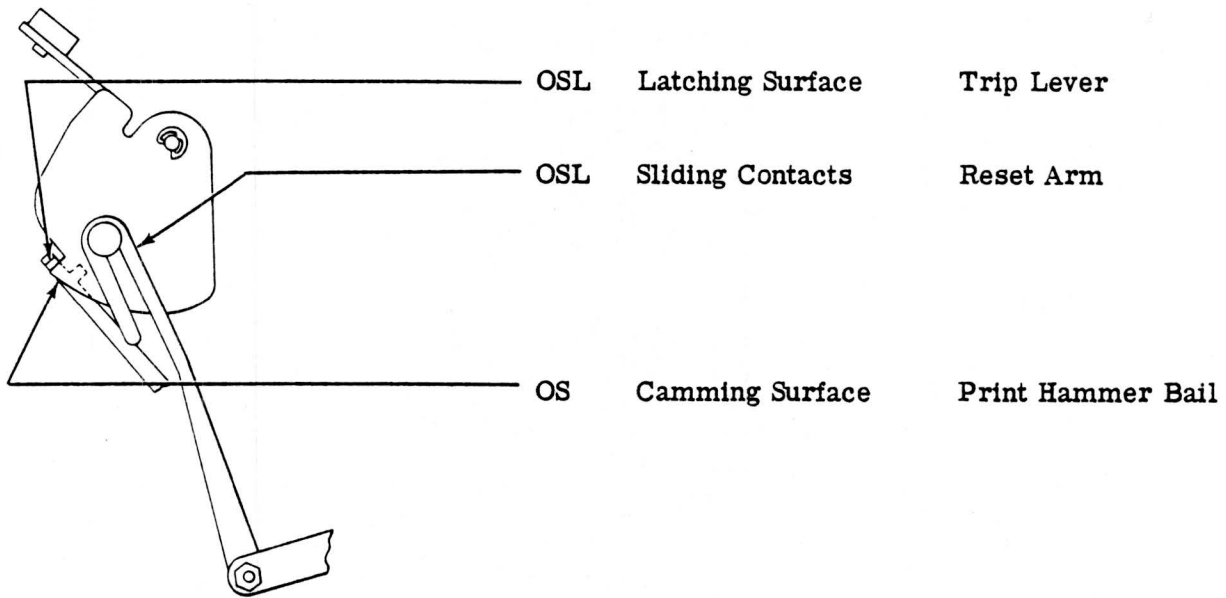

(RIGHT SIDE VIEW)

2.33 Slide Guide Plates - 1

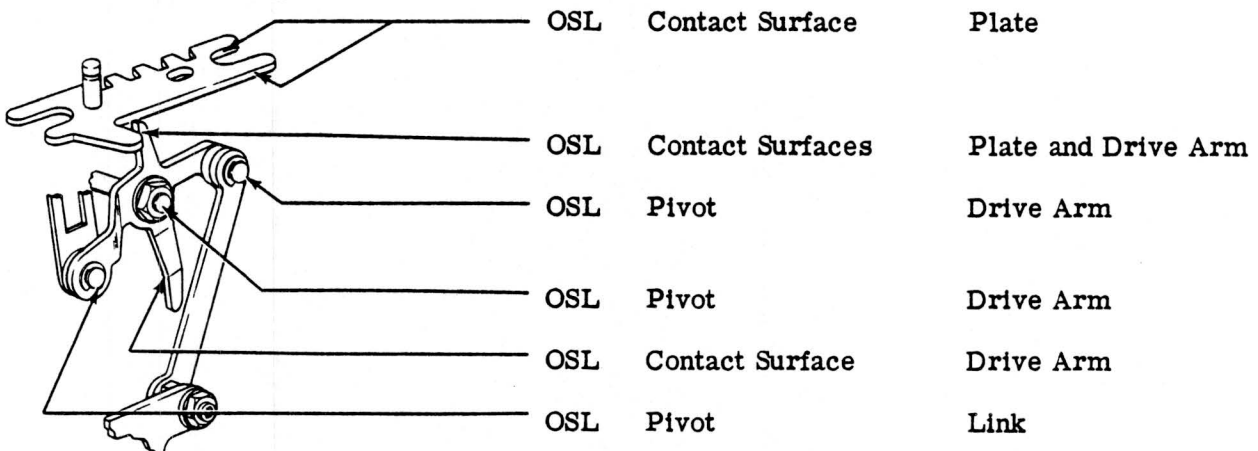

(RIGHT SIDE VIEW)

2.34 Slide Guide Plates - 2

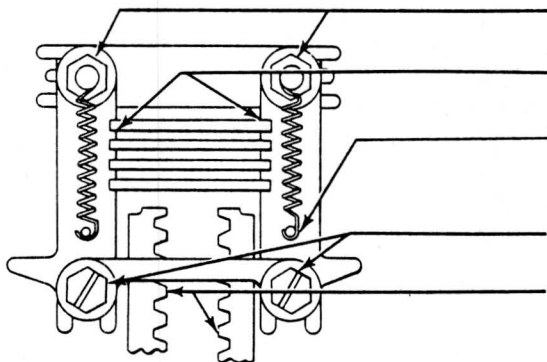

(TOP VIEW)

- |     |                   |                  |
|-----|-------------------|------------------|
| OSL | Sliding Contacts  | Stop Plate       |
| OSL | Engaging Surfaces | Stop Slides (4)  |
| OSL | Hooks (Each End)  | Springs (2)      |
| OSL | Contact Points    | Slide Guides (2) |
| OSL | Teeth             | Pinion Racks (2) |

2.35 Ribbon Guide Spring

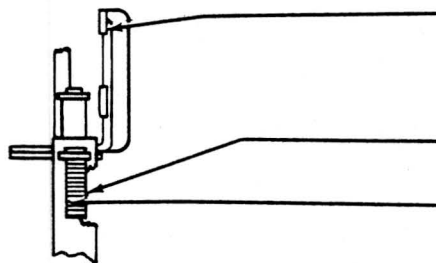

(RIGHT SIDE VIEW)

- |     |                                 |              |
|-----|---------------------------------|--------------|
| D   | Surfaces in Contact With Ribbon | Ribbon Guide |
| OSL | Seat (Each End)                 | Springs (2)  |
| OSL | Sliding Contacts                | Lifter Arm   |

2.36 Typewheel Mechanism

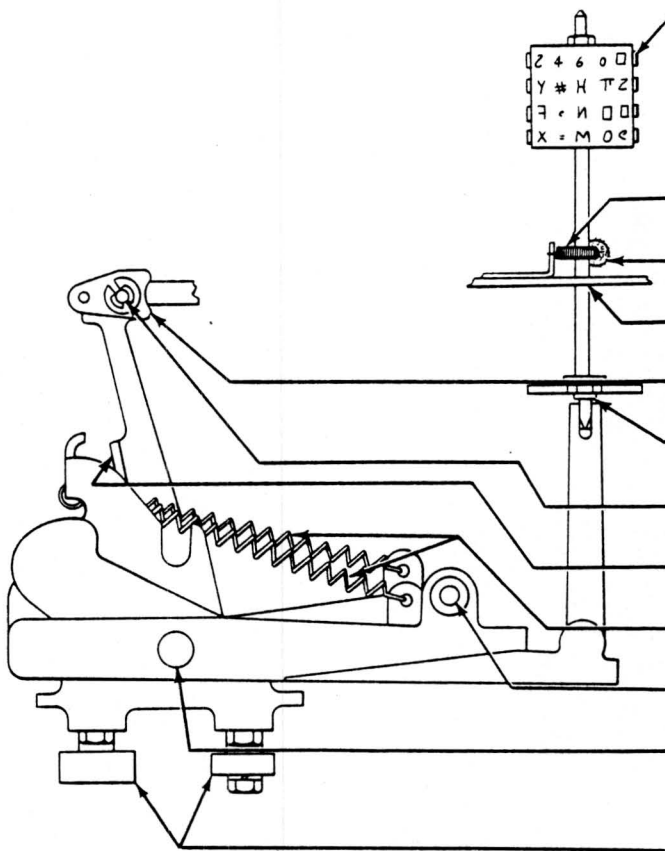

(RIGHT SIDE VIEW)

- |      |                       |                                   |
|------|-----------------------|-----------------------------------|
| D    | Printing Surface      | Typewheel                         |
| OSL  | Hooks (Each End)      | Return Spring                     |
| OSAT | Felt Wick             | Typewheel Shaft                   |
| OL   | Upper Bearing         | Positioning Cage                  |
| OSL  | Engaging Surfaces (2) | Rotary Drive Lever                |
| OL   | Lower Bearing         | Positioning Cage                  |
| OSL  | Pivot                 | Pulse Link                        |
| OSL  | Contact Surface       | Power Bail                        |
| OSL  | Hooks (Each End)      | Springs (2)                       |
| OSL  | Pivot                 | Drive Arm                         |
| OSL  | Pivot                 | Power Bail                        |
| OL   | Bearings              | Rollers (Front and Rear - 2 Each) |

2.37 Slides

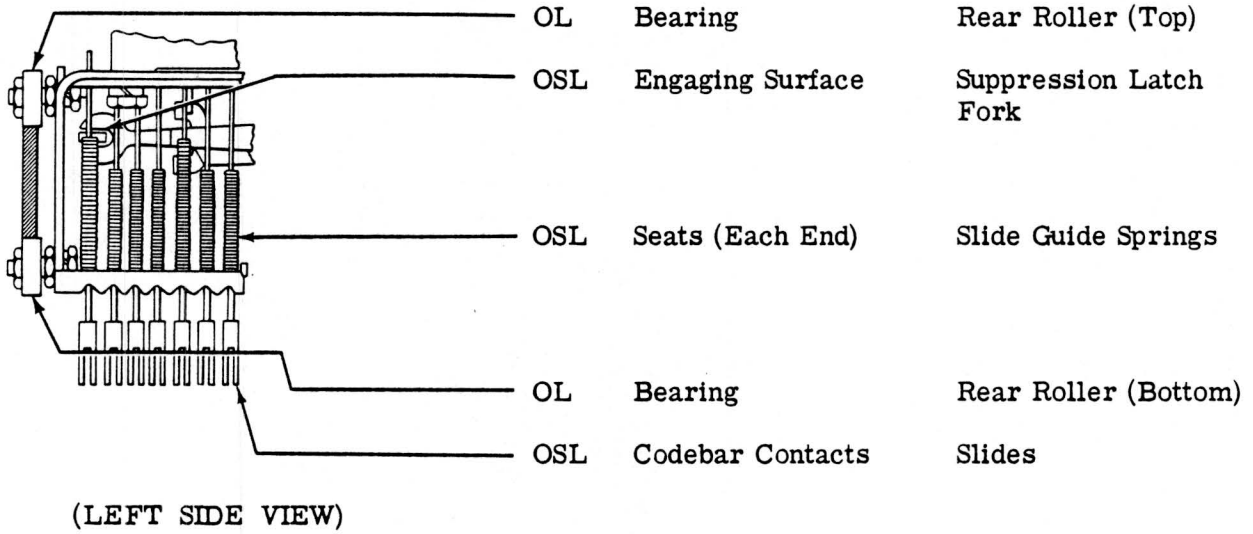

2.38 Ribbon Mechanism

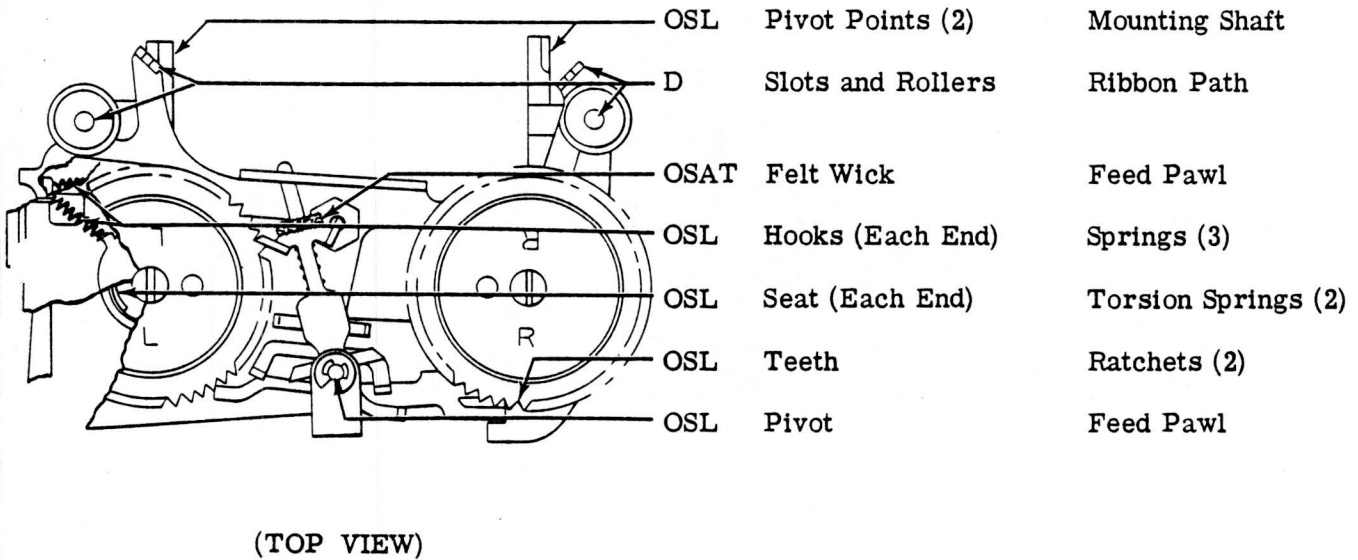

2.39 Motor Area

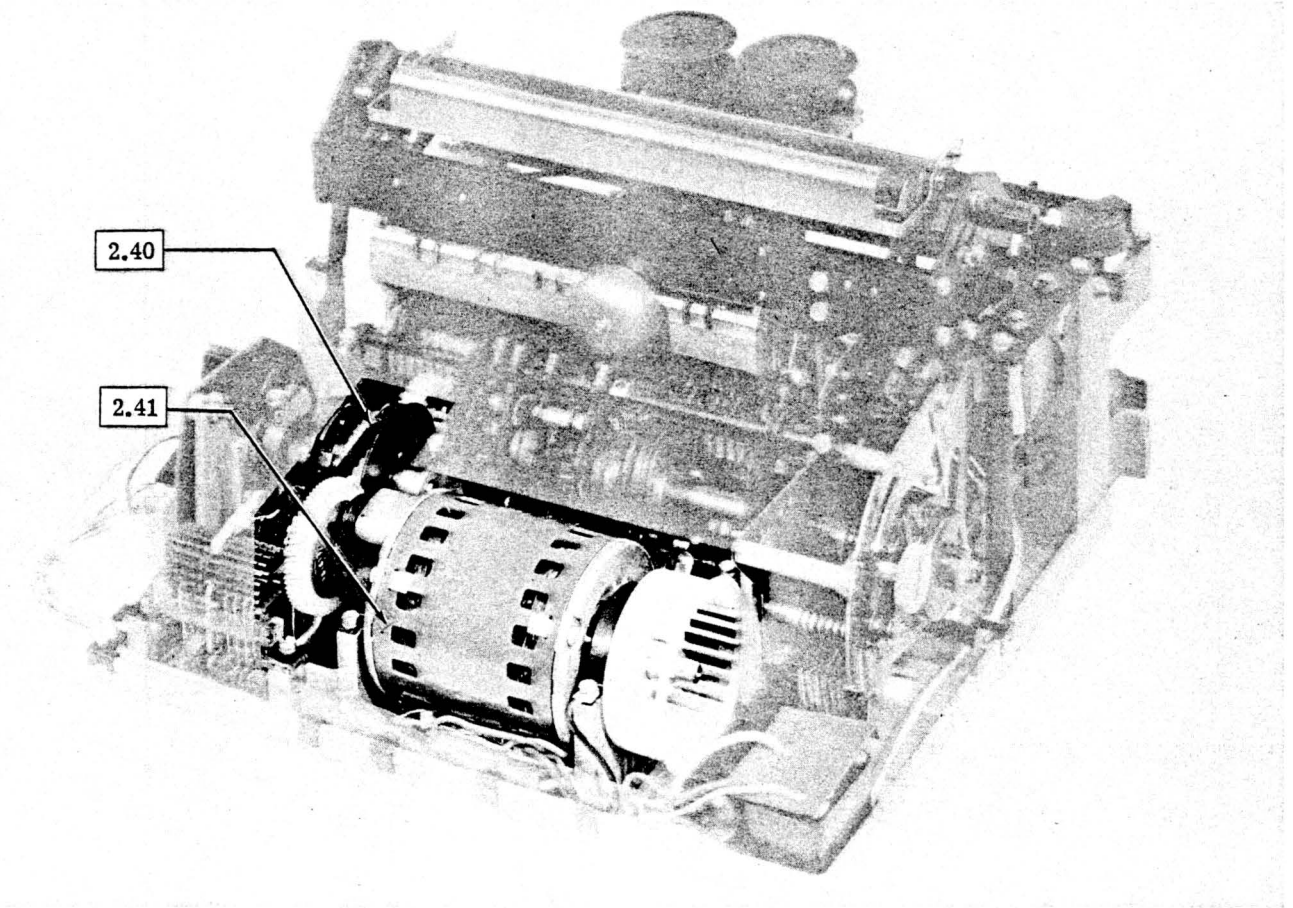

(REAR VIEW)

2.40 Intermediate Gears

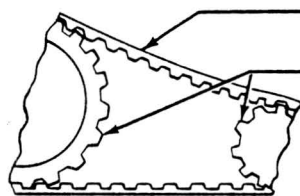

(RIGHT SIDE VIEW)

- D Motor Belt
- D Teeth
- Sprockets (2)

2.41 Motor

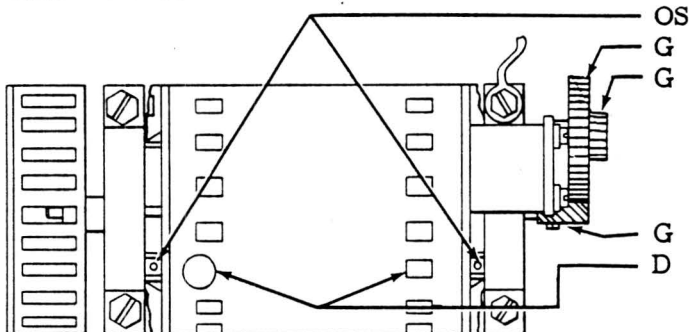

(TOP VIEW)

- Bearings (Each End)
- Teeth
- Pack Grease in Space Between Two Oilite Bearings. Intermediate Gear Must Be Removed.
- Teeth
- Interior Areas
- Motor Shaft
- Intermediate Gear
- Intermediate Gear
- Motor Pinion
- Motor

**CAUTION:** MOTOR START RELAY AND CAPACITOR MUST BE KEPT FREE OF LUBRICANTS.

FRICITION FEED MECHANISMS

2.42 Paper Feed Area

Note: Reinstall ribbon mechanism. For instructions, see the appropriate typing unit section.

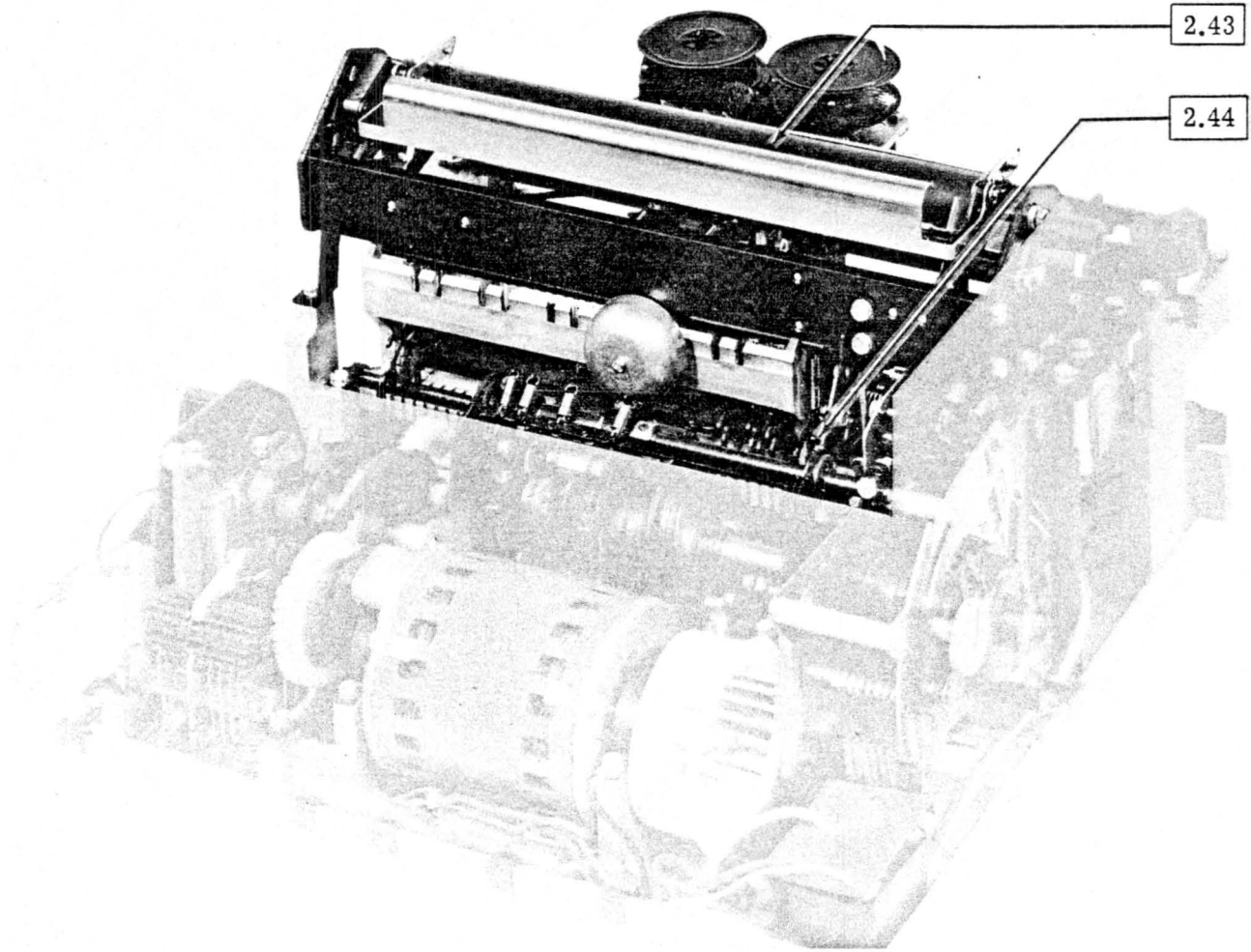

(REAR VIEW)

2.43 Platen

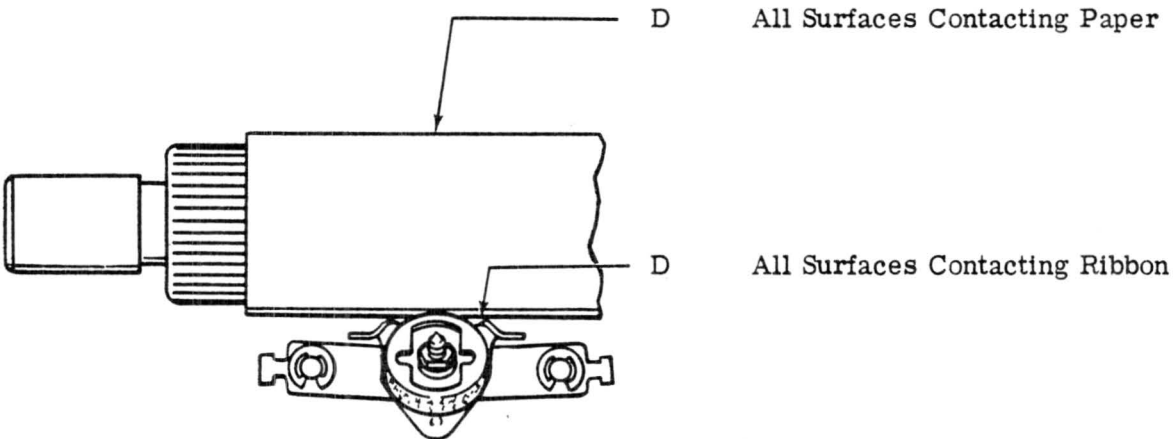

**CAUTION:** DO NOT CLEAN PLATEN WITH SOLVENTS.

2.44 Line Feed Mechanism

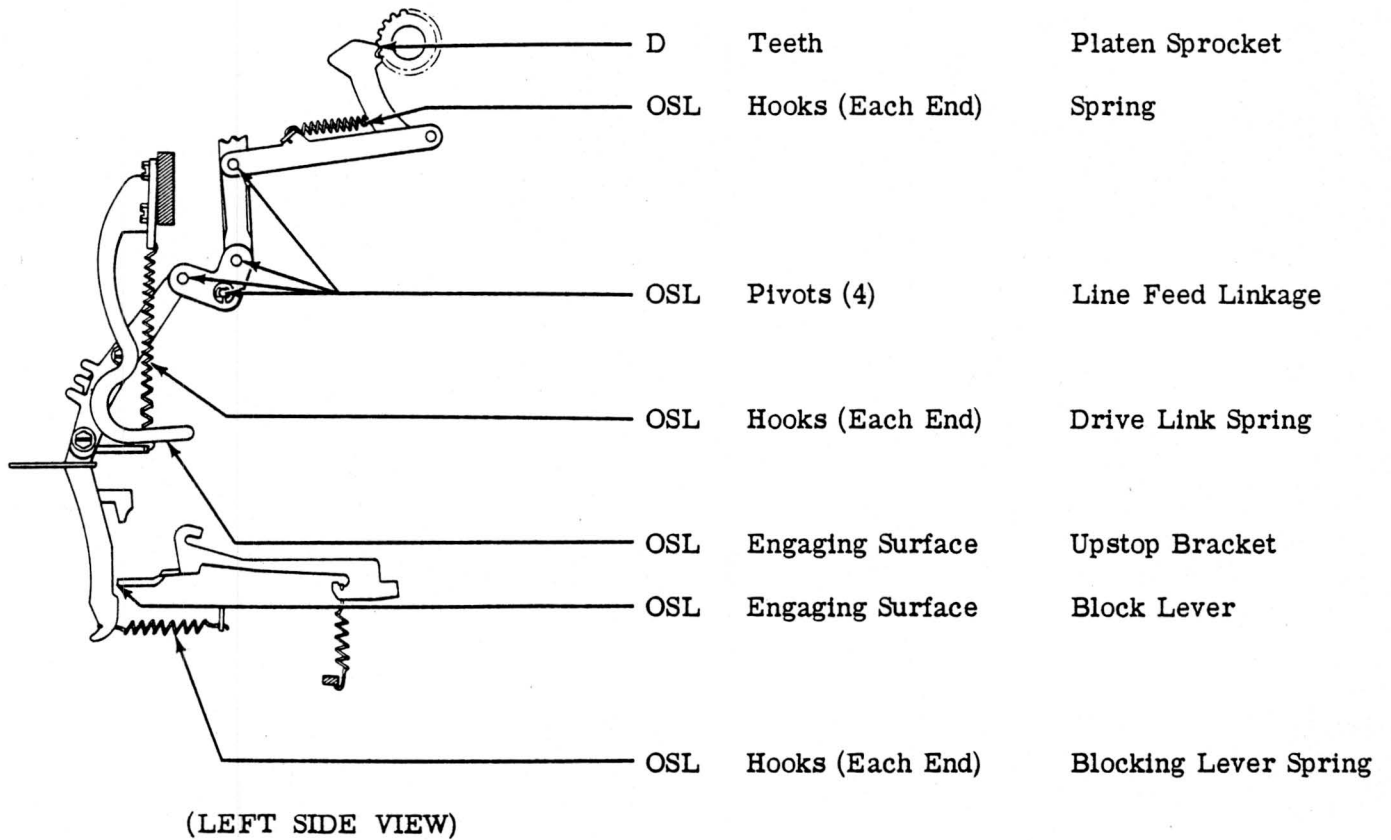

SPROCKET FEED MECHANISMS

2.45 Paper Feed Area

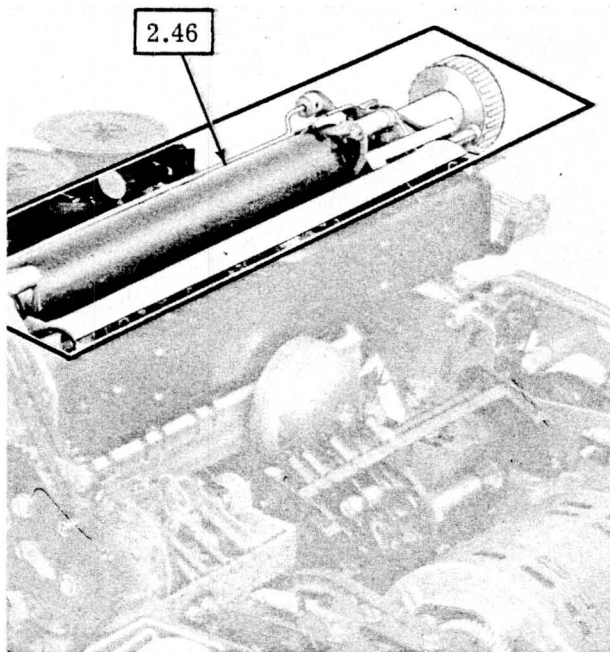

(RIGHT REAR VIEW)

Note: Reinstall ribbon mechanism. For instructions, see the appropriate typing unit section.

2.46 Platen Mechanism

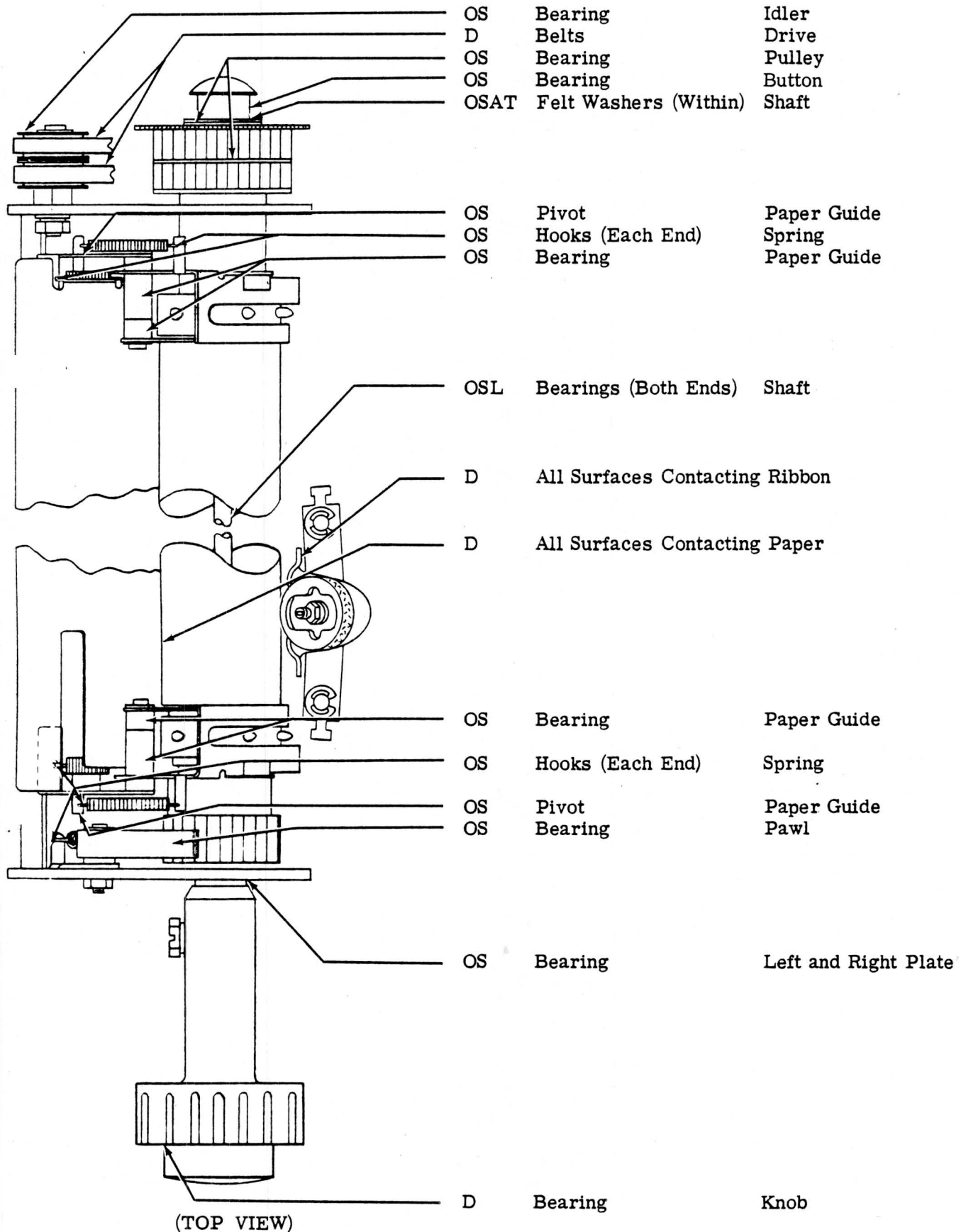

2.47 Platen Drive Area

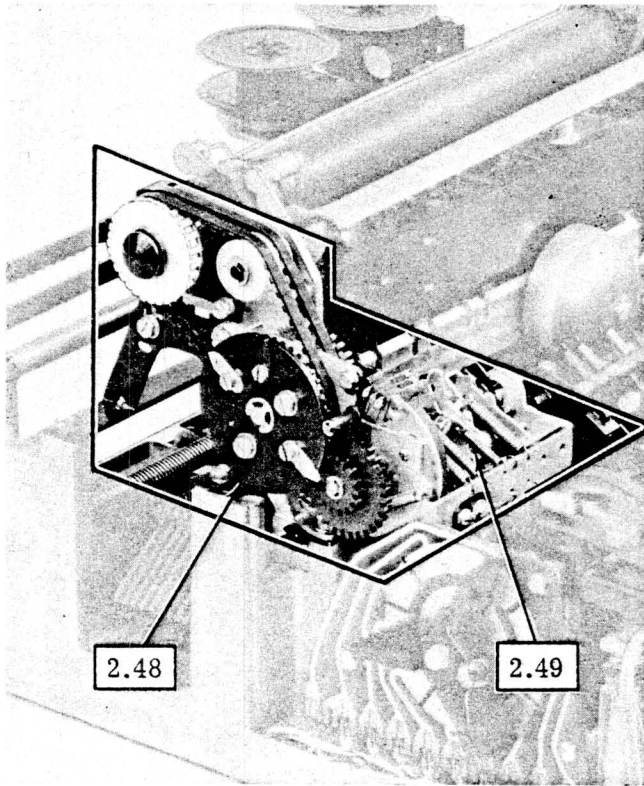

(RIGHT REAR VIEW)

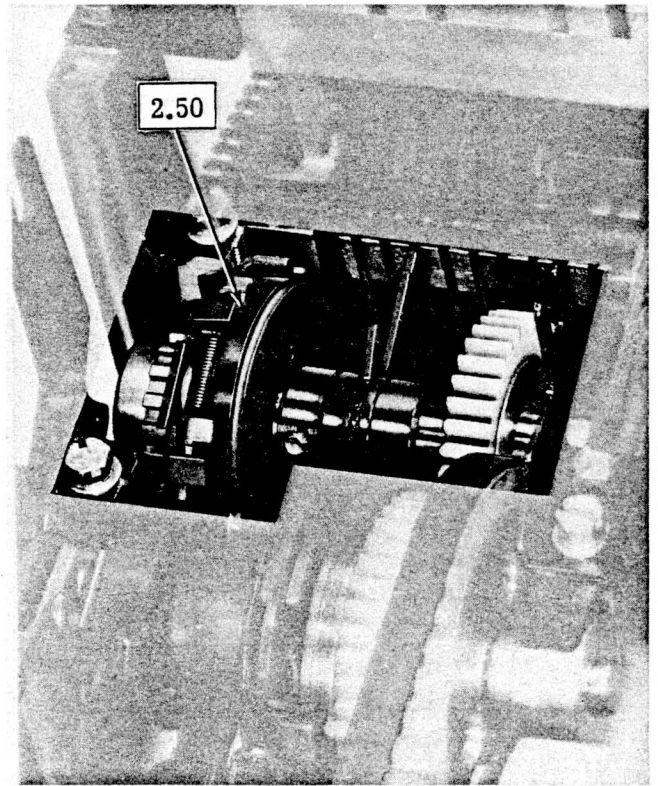

(LEFT REAR VIEW)

(Form-out mechanism removed for illustration purposes. Removal for lubrication is not required.)

2.48 Cam, Pulley, and Gear Combination

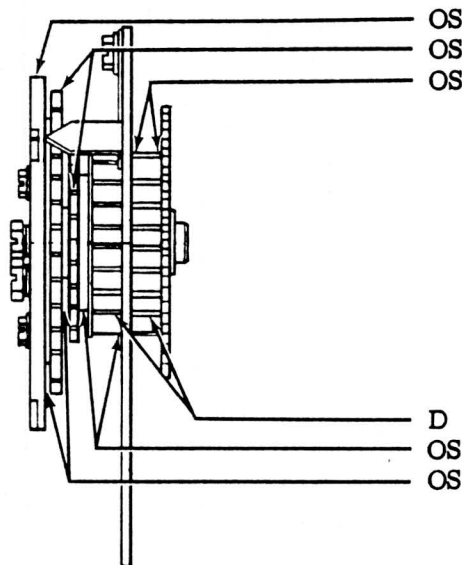

(TOP VIEW)

- |    |              |                 |
|----|--------------|-----------------|
| OS | Cam Surface  | Cam Gear        |
| OS | Gear Surface | Cam Gear        |
| OS | Bearing      | Gear and Pulley |
| D  | Surface      | Pulley          |
| OS | Bearing      | Gear and Pulley |
| OS | Bearing      | Cam Gear        |

2.49 Form-Out Mechanism

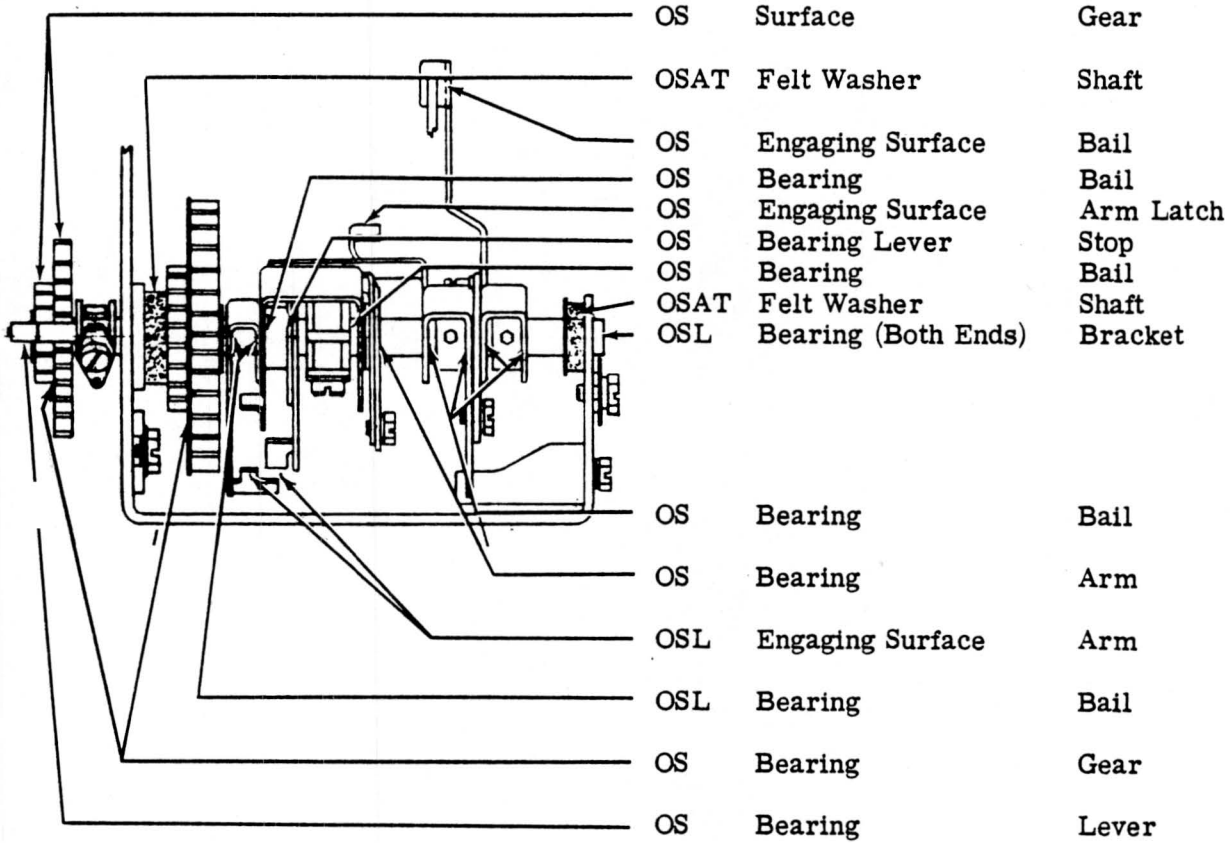

(TOP VIEW)

2.50 Line Feed Clutch

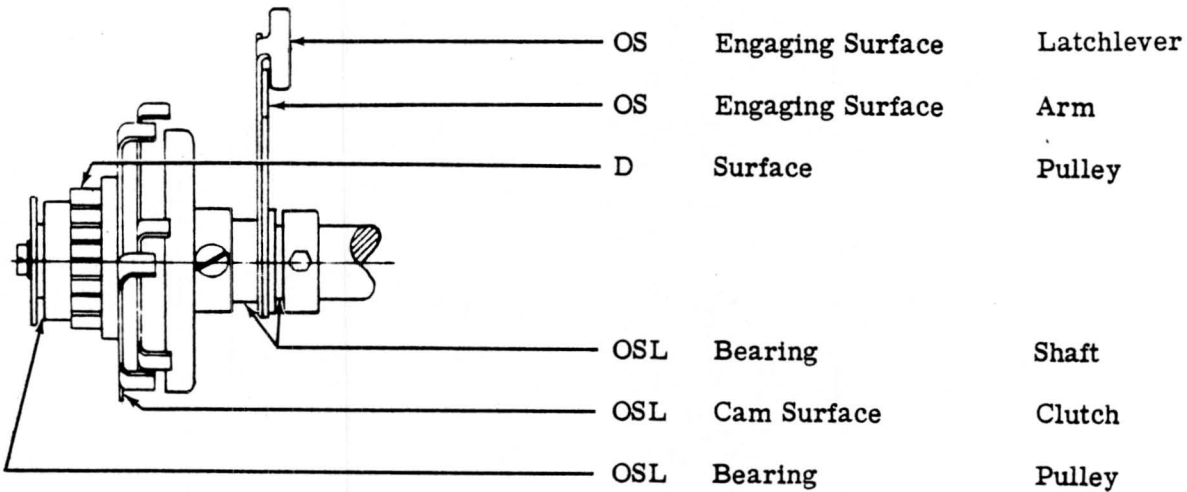

(TOP VIEW)

3. VARIATIONS TO BASIC UNITS

3.01 Answer-Back Area

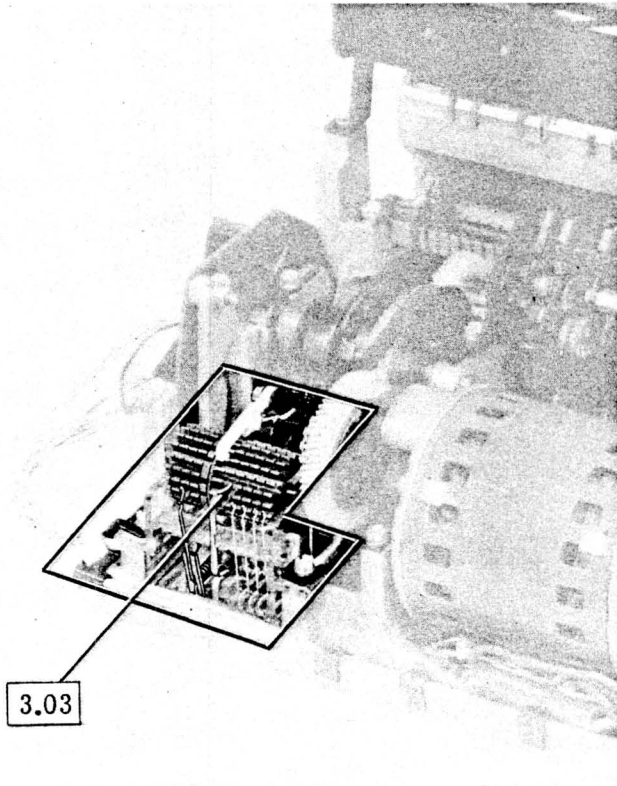

(LEFT REAR VIEW)

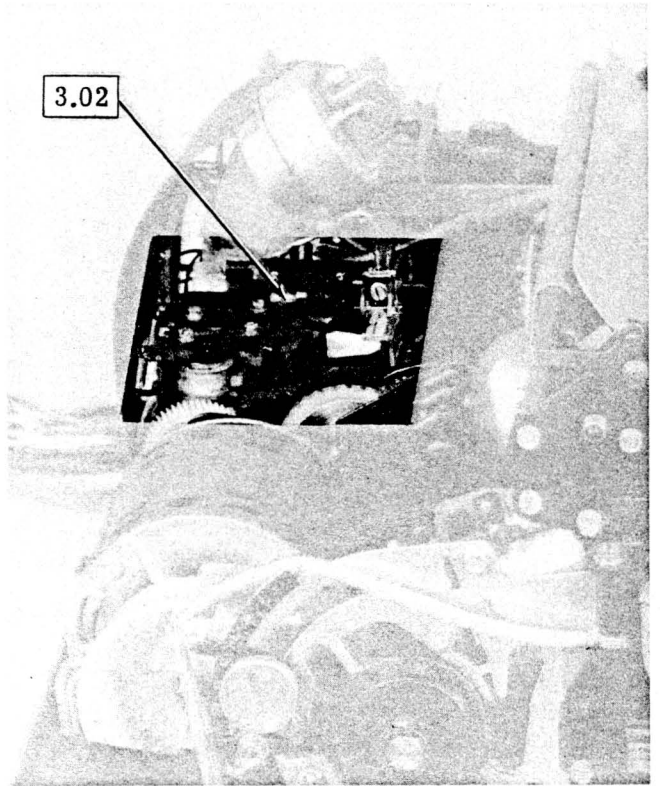

(LEFT SIDE VIEW)

3.02 Trip Magnet

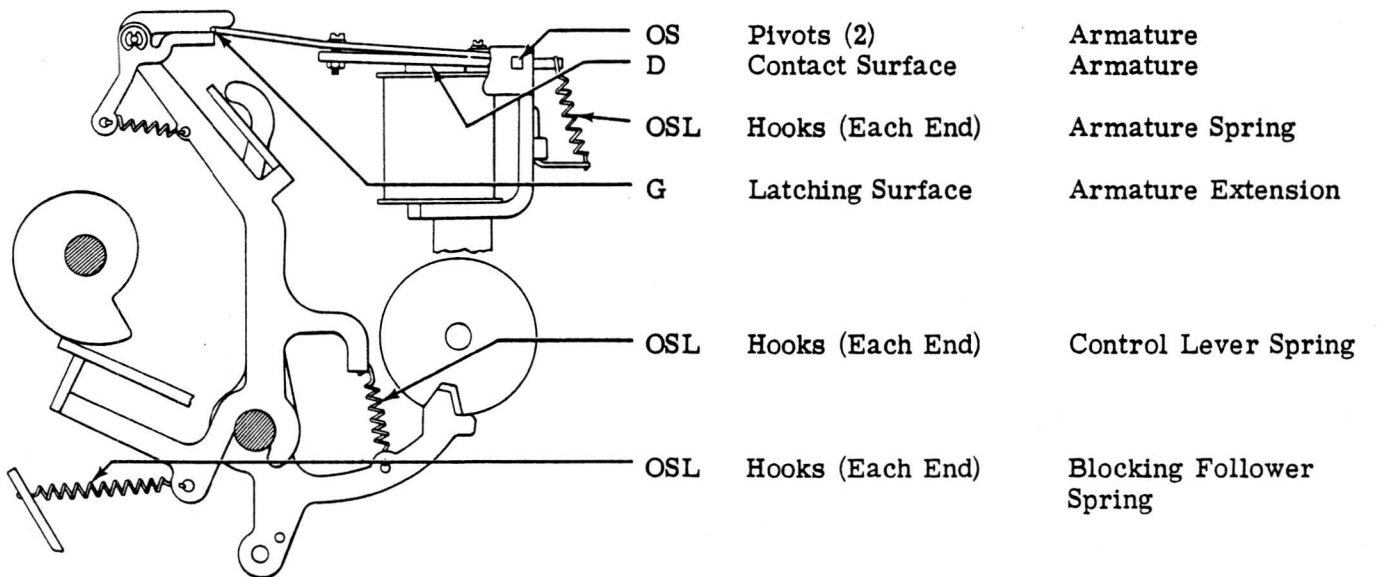

3.03 Answer-Back Mechanism

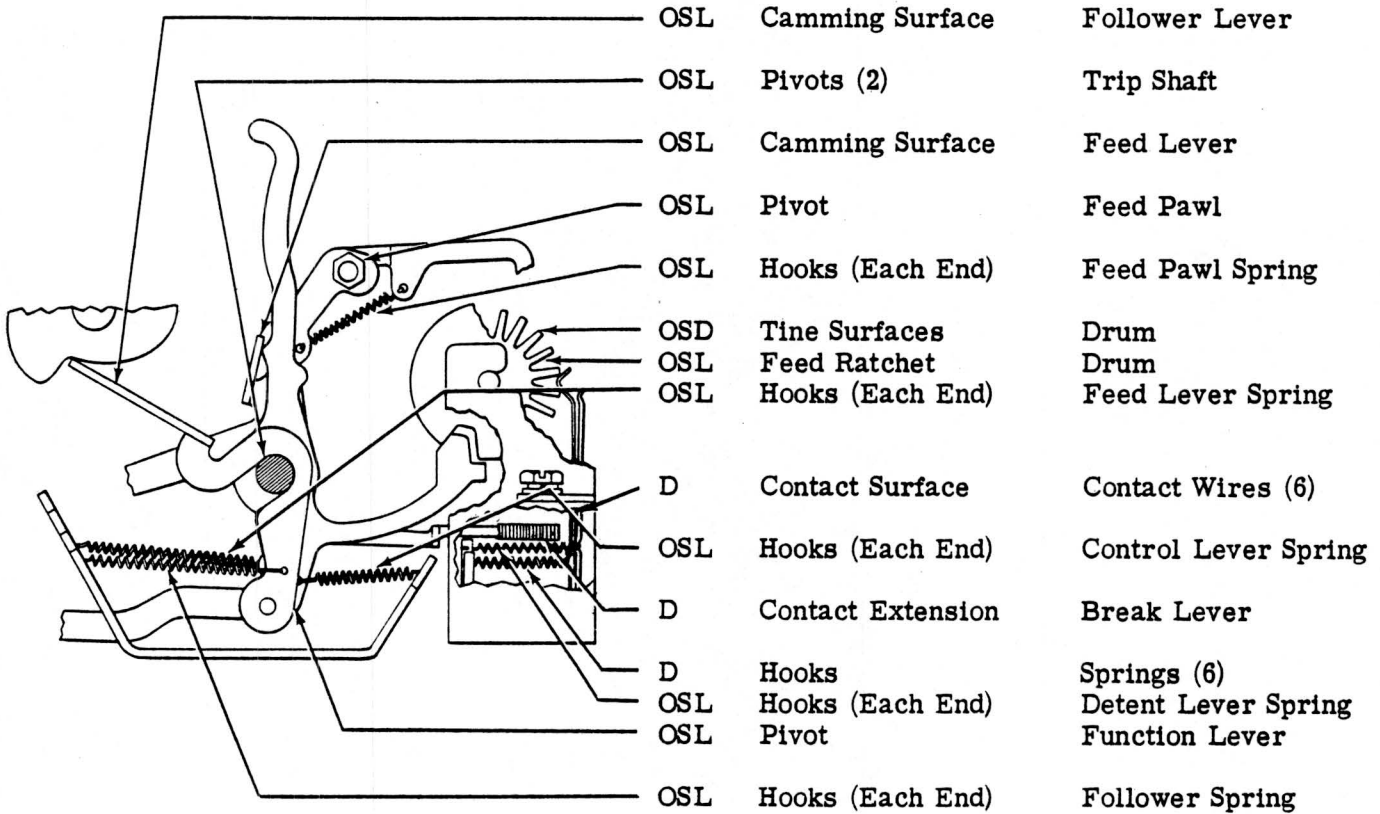

CAUTION: DO NOT CLEAN CONTACT BLOCK WITH SOLVENTS.

32 AND 33 TYPING UNIT  
DISASSEMBLY AND REASSEMBLY

CONTENTS	PAGE
1. GENERAL.....	1
2. DISASSEMBLY AND REASSEMBLY ..	1

1. GENERAL

1.01 This section is issued to provide disassembly and reassembly instructions for the 32 and 33 typing unit and to present the instructions as a separate section.

1.02 References to "left," "right," "front," or "rear," etc consider the typing unit to be viewed from a position where the ribbon mechanism faces up and the selector mechanism is located to the viewer's left.

1.03 The disassembly procedure given in this section will break the typing unit down into its major assemblies and mechanisms. If further disassembly is required, refer to the appropriate illustrated parts section which shows detailed arrangements of parts. Where it will help in determining their location, the numbers of the parts are given in the instructions.

2. DISASSEMBLY AND REASSEMBLY

**CAUTION:** BEFORE BEGINNING DISASSEMBLY, REMOVE CONNECTORS FROM EXTERNAL RECEPTACLES (POWER SOURCE, DATA SET, ETC).

2.01 General:

(a) Most of the mechanisms are mounted on castings by self-tapping screws. Therefore, to remove the mechanisms, do not remove the screws. Merely loosen them unless specifically instructed otherwise.

(b) Retaining rings are made of spring steel and have a tendency to release suddenly. To avoid loss of these rings when removing them, proceed as follows:

(1) Hold retaining ring to prevent its rotating.

(2) Place blade of screwdriver in one of ring's slots and rotate screwdriver to increase diameter.

(3) Ring will come off easily in fingers without flying.

2.02 Common Mechanisms:

(a) To remove typing unit proceed as follows:

Note: Reference Figures 1, 2, and 3.

(1) Remove all plugs which terminate wires leading from the typing unit from their receptacles on call control unit. Remove ground strap from ground tab on call control unit.

(2) Insert screwdriver in slot in TP180977 H-plate and push to left against pressure of spring until plate is disengaged from universal lever. Remove H-plate.

Note: If the keyboard has been disassembled from the subbase, the H-plate will already have been removed. See the appropriate keyboard section.

(3) Lift typing unit from subbase.

(4) To replace typing unit, reverse procedure used to remove it. Make sure that the typing unit is properly seated on rubber isolators and TP180831 answer-back bellcrank is under and aligned with

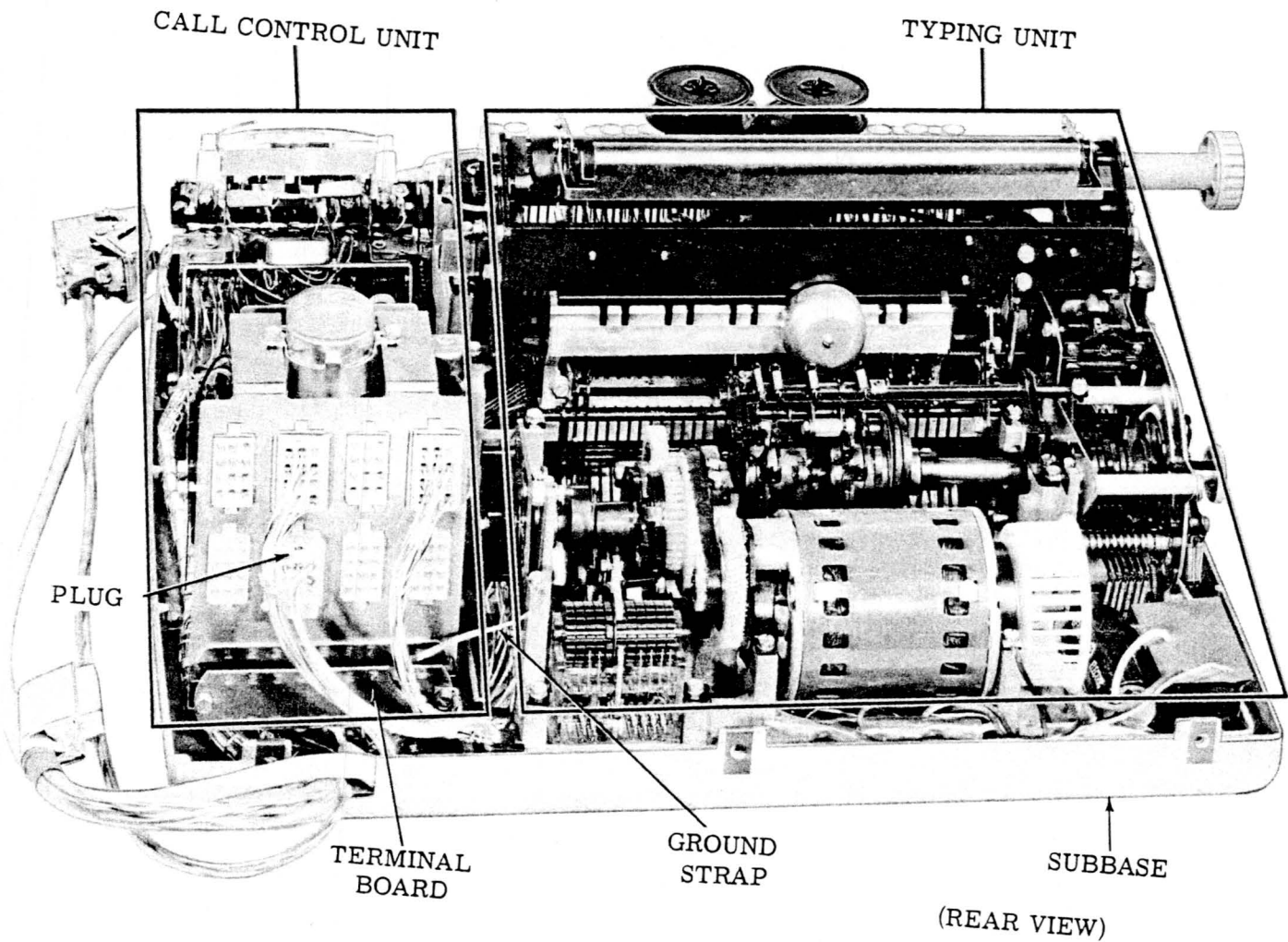

Figure 1 - Typing and Call Control Units

HERE IS keylever. Replace plugs into proper receptacles on call control unit.

- (b) To remove ribbon mechanism, proceed as follows:

Note: Reference Figure 2.

- (1) Remove ribbon by removing two ribbon spools and disengaging ribbon from ribbon guide and TP181116 reverse arm.
- (2) Loosen two TP152893 mounting screws and lift ribbon mechanism from carriage.

- (3) To replace ribbon mechanism, reverse procedure used to remove it.

- (c) To remove carriage mechanism, proceed as follows:

Note: Reference Figures 2 and 5.

- (1) Unhook carriage return spring from carriage.
- (2) Loosen two TP180798 mounting screws in spacing pulley's mounting bracket. Rotate and remove bracket.

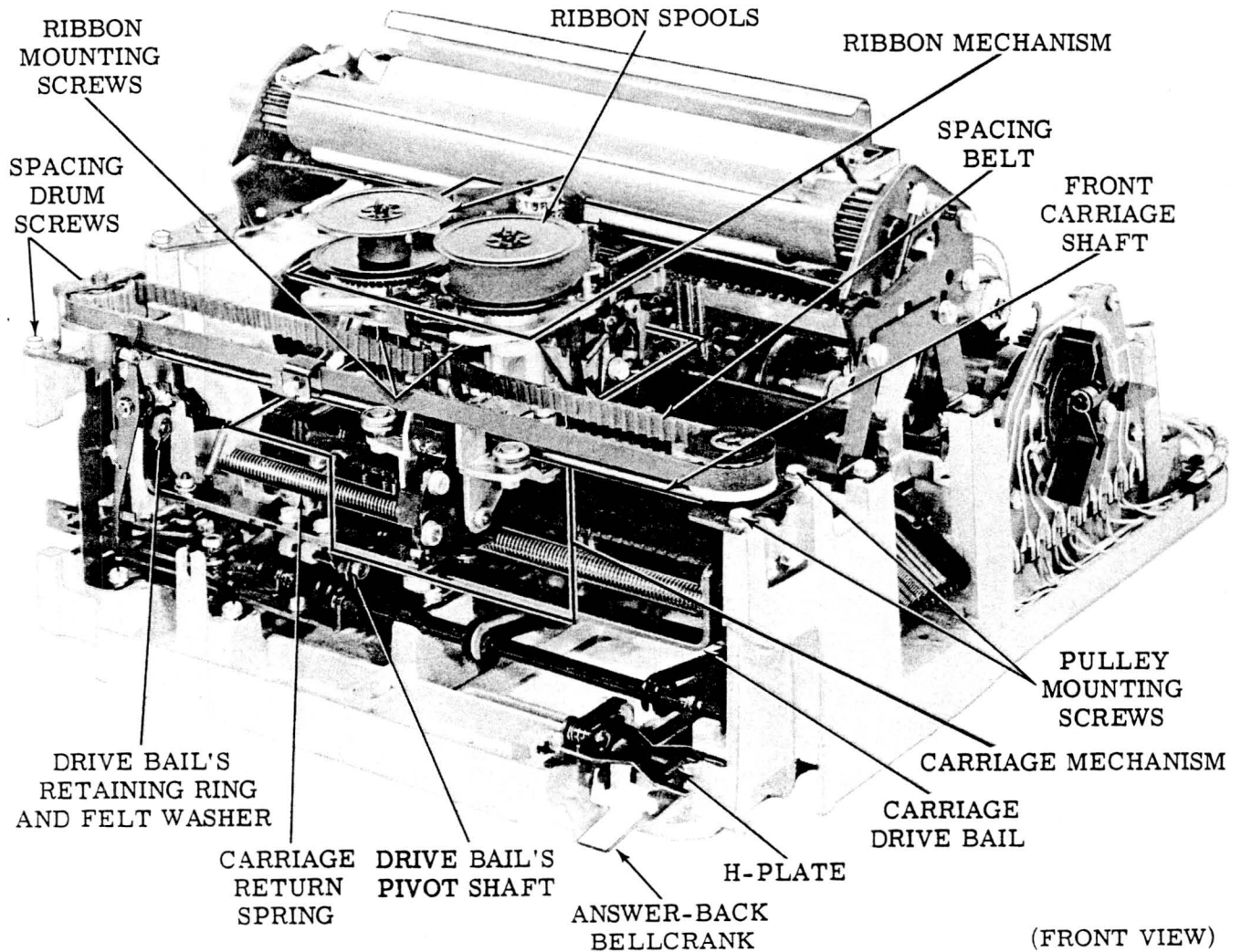

Figure 2 — Typing Unit

- (3) Loosen two TP180798 mounting screws in spacing drum's mounting bracket. Remove mounting bracket.
- (4) Disengage spacing belt from pulley on spacing drum.
- (5) Remove front carriage shaft by sliding to right.
- (6) Disengage rollers from rear plate and lift carriage from typing unit.
- (7) To replace carriage mechanism, reverse procedure used to remove it and observe following precautions:
  - (a) Make sure nylon slide guides engage proper associated codebars.

- (b) Make sure two rear rollers engage carriage rear plate.

- (d) To remove selector mechanism, proceed as follows:

Note: Reference Figure 4.

- (1) Lock armature in spacing position to prevent it from pulling selector levers from their guide.
- (2) Remove TP150040 mounting screw with lock washer from selector clutch.
- (3) Holding levers away, remove selector clutch from main shaft by pulling to left and rotating back and forth.

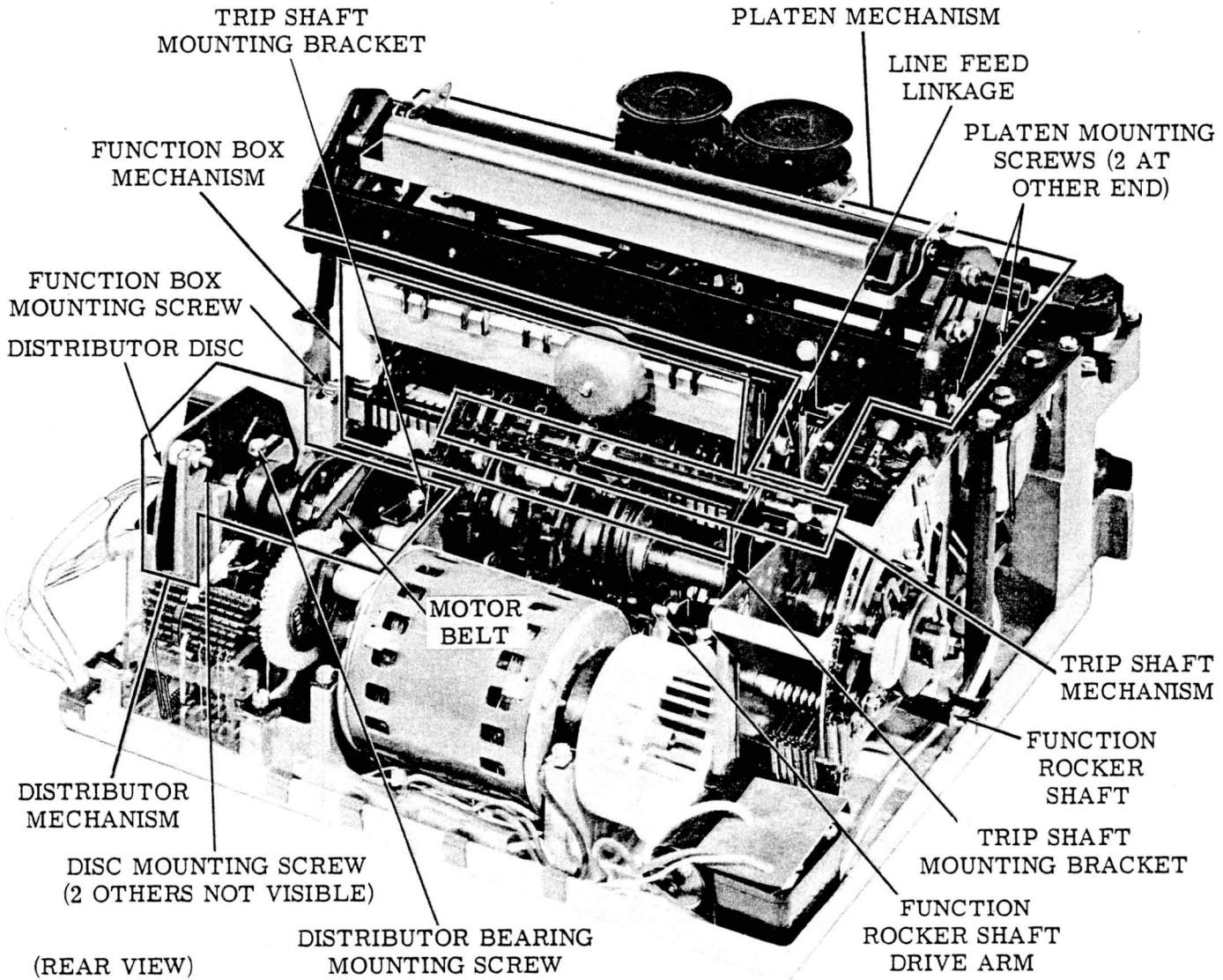

Figure 3 — Typing Unit

- (4) From underside of base casting, remove TP180798 mounting screw from bottom of left platen support post. Loosen TP180798 screw in top of post and remove it and dashpot cylinder.
- (5) Loosen TP181246 mounting screw in TP180648 follower arm. Slide arm off trip shaft.
- (6) Loosen TP180798 mounting screw and remove TP180682 upstop bracket. Tighten screw to secure TP181230 retaining plate.

- (7) Remove three TP180675 mounting screws with TP180676 speed nuts from selector plate.
- (8) Loosen screws and remove two leads from selector magnet.
- (9) Remove selector mechanism.
- (10) To replace selector mechanism, reverse the procedure used to remove it with following precautions:
  - (a) Make sure blocking levers are properly seated to guide slots in front TP180950 codebar tie bracket.

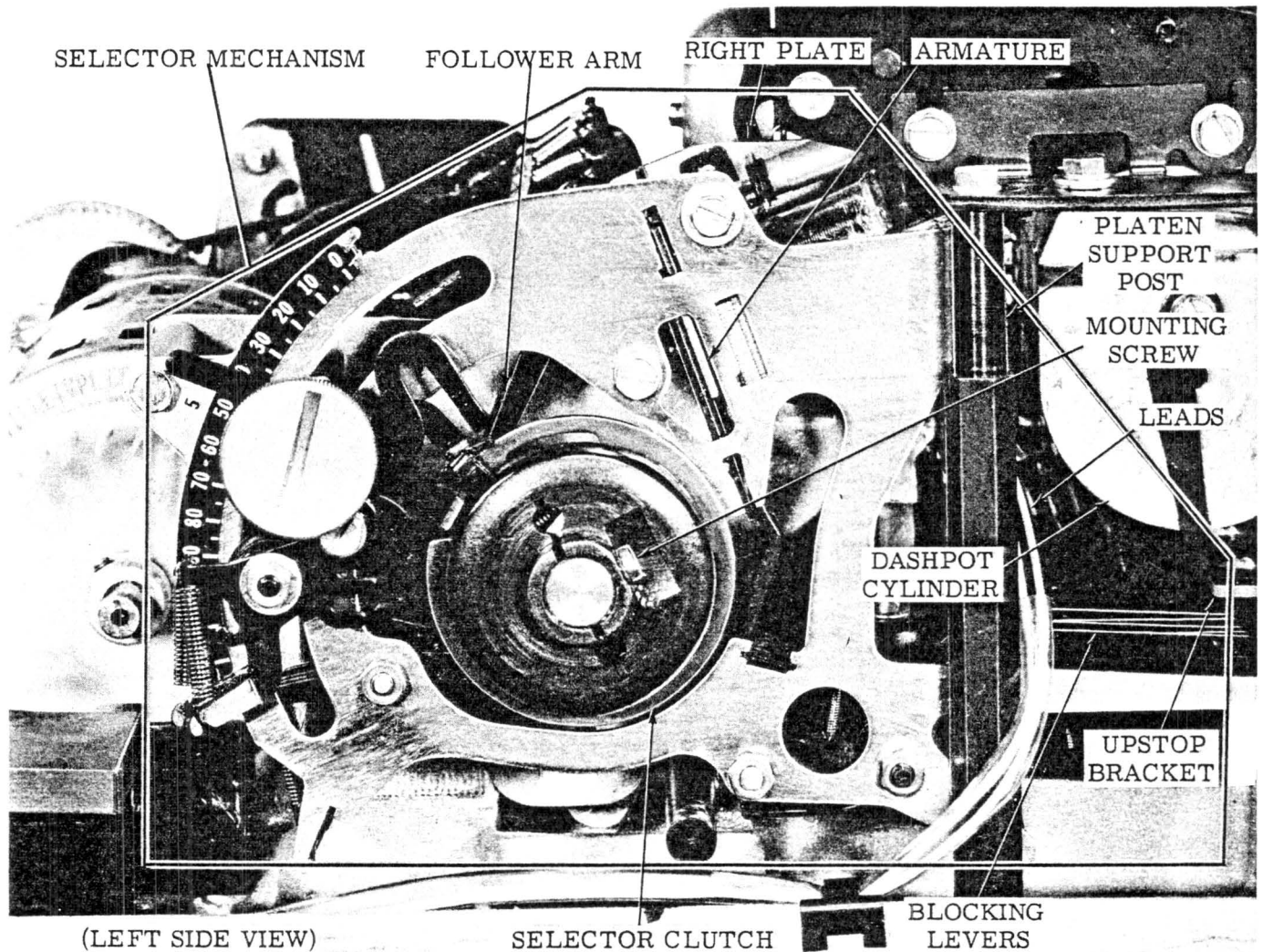

Figure 4 — Selector Mechanism

- (b) To prevent bending right plate, make sure it is properly fitted around TP181006 bearing on main shaft.
- (e) To remove codebar mechanism, proceed as follows:
- Note: Reference Figures 5 and 6.
- (1) Loosen four TP180798 mounting screws, remove four TP180925 clamps and lift codebar mechanism from frame.
  - (2) To replace codebar mechanism, reverse procedure used to remove it and observe the following precautions:
    - (a) Make sure function levers are in proper slots in codebars.
    - (b) Make sure codebars' reset extensions are to right of TP180928 codebar reset bail and in proper slots of guide.
    - (c) Make sure both right and left TP180920 guide shafts are fully seated in their mountings.

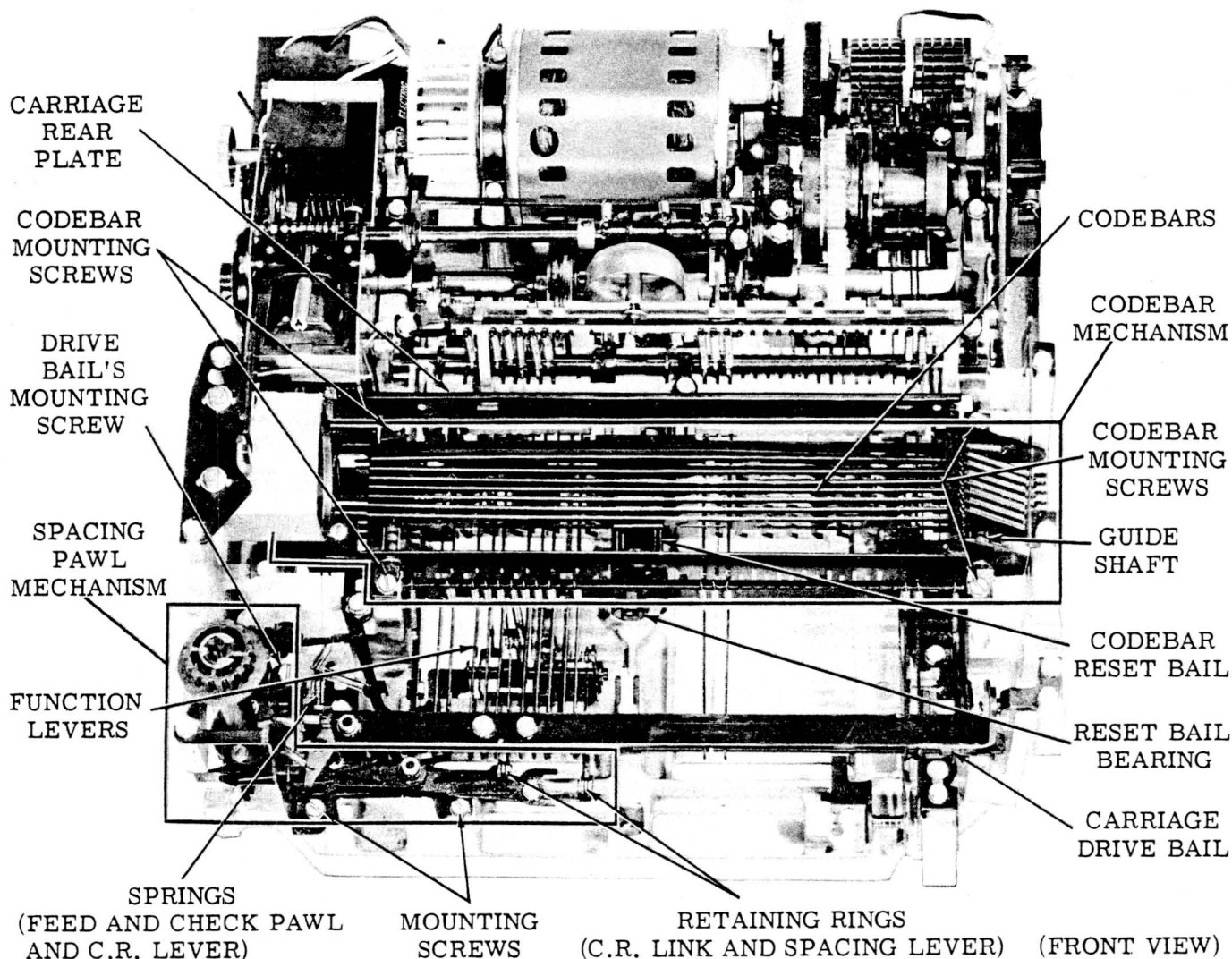

Figure 5 — Typing Unit (Carriage and Platen Removed)

- (d) Make sure TP181070 space suppression lever is to the left of TP180947 print suppression codebar.
- (e) Make sure TP180752 print suppression latchlever fits into slot of TP180923 bracket mounted on the rear tie bracket.
- (f) Make sure that the left ends of the codebars fully engage their respective blocking lever tines.
- (f) To remove trip shaft mechanism, proceed as follows:

Note: Reference Figure 3.

- (1) Loosen four TP180798 mounting screws in left and right mounting brackets. Push inwards on brackets and lift mechanism from base casting.
- (2) To replace trip shaft mechanism, reverse procedure used to remove it.
- (g) To remove function box mechanism, proceed as follows:

Note: Reference Figures 3, 5, and 7.

- (1) Unhook TP74702 spring (connects to TP180928 codebar reset bail) from TP180773 plate.

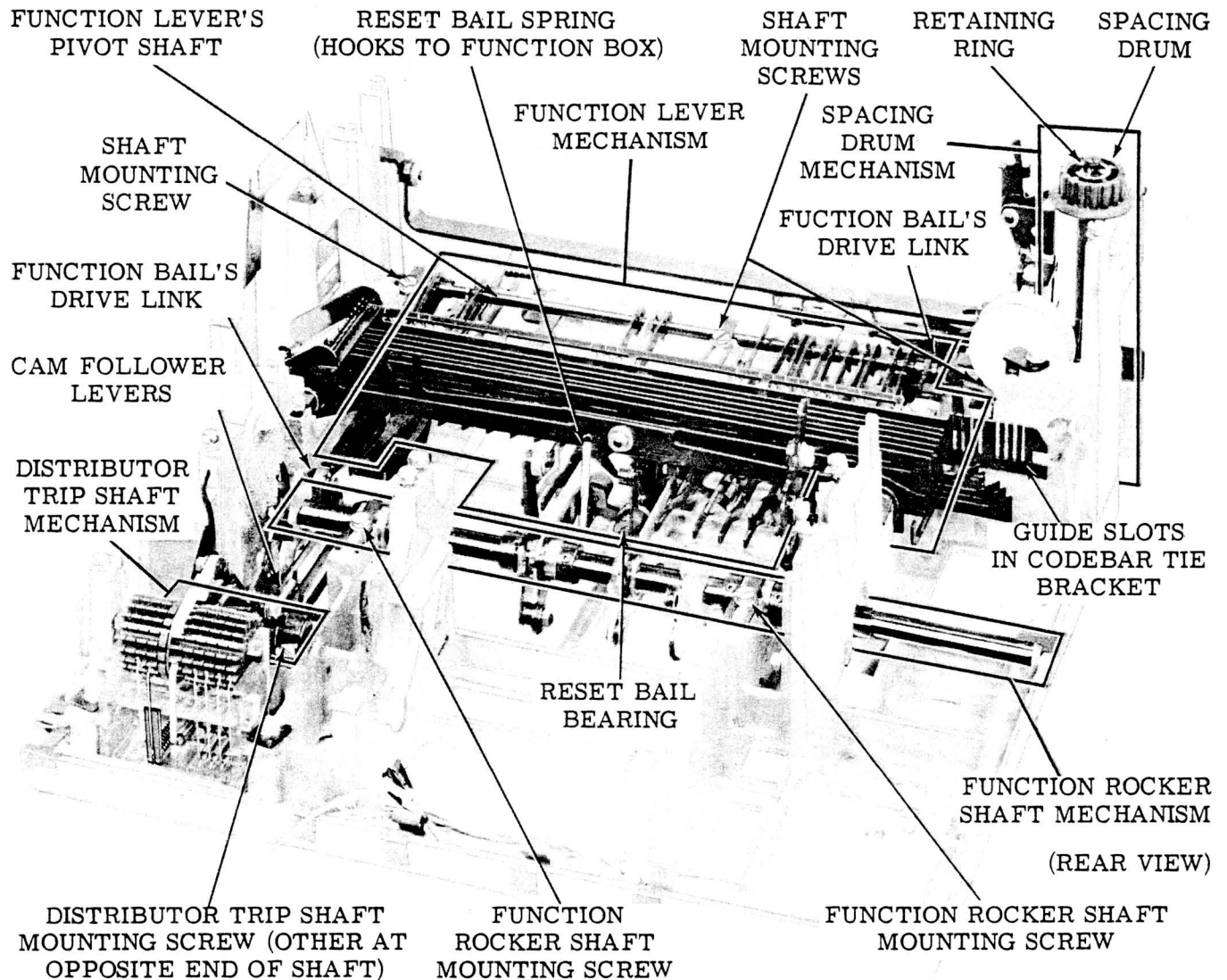

Figure 6 — Typing Unit (A Number of Mechanisms Removed)

- (2) Loosen two TP180798 mounting screws and remove two TP180796 clamp plates.
- (3) Lift function box mechanism from base casting.
- (4) To replace function box mechanism, reverse procedure used to remove it with following precaution:
- Function levers should be in proper slots and aligned with their respective pawls.
- (h) To remove main shaft mechanism, proceed as follows:
- Note: Reference Figures 2, 3, and 7.
- (1) Remove TP3598 nut and flat washer from TP180546 pivot shaft on carriage drive bail. Disengage front end of TP181005 drive link from pivot shaft.
- (2) Remove TP119649 retaining ring from function rocker shaft's TP180774 drive arm. Disengage TP180746 arm on function rocker shaft from drive arm.
- (3) Position main shaft mechanism to right and lift from base casting.
- (4) To replace main shaft mechanism, reverse procedure used to remove it. Make sure distributor shaft is properly positioned to left against pressure of brush spring.

- (i) To remove distributor mechanism, proceed as follows:

Note: Reference Figure 3.

- (1) Loosen TP180798 mounting screw and remove TP180797 retaining plate from bearing near right end of distributor shaft.
- (2) Loosen TP151721 and two TP180989 mounting screws in distributor disc.
- (3) Slide wire leads out of connections on distributor disc.
- (4) Remove motor belt.
- (5) Lift distributor mechanism from base casting.
- (6) To replace distributor mechanism, reverse procedure used to remove it with following precaution:

Make sure leads are inserted into proper connections on disc. (See the appropriate wiring diagram.)

- (j) To remove distributor trip shaft mechanism, proceed as follows:

Note: Reference Figure 6.

- (1) Remove TP119649 retaining ring from post connecting links to each of following cam follower levers: TP180985, TP180820, and TP180821.
- (2) Unhook five springs from TP180988 spring bracket.
- (3) Loosen two TP180798 mounting screws and remove two TP180972 buffer clamps.
- (4) Remove distributor trip shaft mechanism from base casting.
- (5) To replace distributor trip shaft mechanism, reverse procedure used to remove it.

- (k) To remove motor, proceed as follows:

Note: Reference Figure 7.

- (1) Remove four TP180798 mounting screws and two motor clamps.

- (2) Disengage motor belt from gear pulley mounted on motor housing.

- (3) Loosen TP180798 screw in motor start relay.

- (4) Remove motor, motor capacitor, start relay, and associated wiring.

- (5) To replace motor, reverse procedure used to remove it.

- (l) To remove function rocker shaft mechanism, proceed as follows:

Note: Reference Figure 6.

- (1) Remove TP119651 retaining rings from posts at rear of TP180769 left and TP180770 right function bail's drive links.

- (2) Loosen two TP180798 mounting screws and remove two TP180797 plates on left and right function rocker shaft bearings.

- (3) Lift function rocker shaft mechanism from base casting.

- (4) To replace function rocker shaft mechanism, reverse procedure used to remove it.

- (m) To remove codebar reset bail, proceed as follows:

Note: Reference Figures 5 and 6.

- (1) From underside of base casting, remove TP153841 screw with lock-washer and TP181247 screw from two TP180930 bearings.

- (2) Lift TP180928 codebar reset bail from base casting.

- (3) To replace codebar reset bail, reverse procedure used to remove it. In replacing TP153841 screw, make sure it passes through TP180776 spring bracket before entering bearing.

- (n) To remove spacing drum mechanism, proceed as follows:

Note: Reference Figure 6.

- (1) Remove TP119653 retaining ring from top of spacing drum and remove drum.
  - (2) From underside of base casting, remove the TP112626 nut and lockwasher from lower end of spacing drum shaft.
  - (3) Lift spacing drum shaft from base casting.
  - (4) To replace spacing drum mechanism, reverse procedure used to remove it.
- (o) To remove carriage drive bail, proceed as follows:

Note: Reference Figures 2 and 5.

- (1) Loosen TP180798 mounting screw and remove TP181230 clamp plate at left end of carriage drive bail.
  - (2) Remove TP119651 retaining ring and felt washer at right end of bail.
  - (3) Remove drive bail by sliding it to left.
  - (4) To replace drive bail assembly, reverse procedure used to remove it.
- (p) To remove spacing pawl mechanism, proceed as follows:

Note: Reference Figure 5.

- (1) Unhook the TP76397 spring from TP181067 feed pawl, TP70466 spring from TP181065 check pawl, and TP70388 spring from TP181319 carriage return lever.
  - (2) Remove TP119649 retaining rings from TP181314 carriage return link and TP181068 spacing lever.
  - (3) Loosen two TP180798 mounting screws.
  - (4) Lift spacing pawl mechanism from base casting.
  - (5) To replace spacing pawl mechanism, reverse the procedure used to remove it.
- (q) To remove function lever mechanism, proceed as follows:

Note: Reference Figure 6.

- (1) Loosen three TP180798 mounting screws and rotate levers' pivot shaft so flat side is vertical.
- (2) To remove any function lever unhook its spring and disengage lever from pivot shaft.
- (3) To remove levers' pivot shaft, remove two TP180797 clamp plates and TP180795 spring bracket. Lift out shaft with two drive links attached.
- (4) To replace function lever mechanism, reverse the procedure used to remove it.

### 2.03 Friction Feed Mechanism:

- (a) To remove platen mechanism, proceed as follows:

Note: Reference Figure 3.

- (1) Remove TP119651 retaining ring and TP90615 spring from line feed linkage.
- (2) Disengage TP181176 link from TP181168 bellcrank.
- (3) Loosen four TP181242 mounting screws in two platen side plates.
- (4) Lift platen mechanism from typing unit.

- (b) To replace platen mechanism, reverse procedure used to remove it.

### 2.04 Sprocket Feed Mechanisms:

- (a) To remove the platen mechanism, proceed as follows:

Note: Reference Figures 3 and 8.

- (1) Loosen TP3598 nut on TP183351 idler post. Back off two TP183341 idlers and slip two TP183379 belts off sprockets.
- (2) Loosen four TP181242 mounting screws in two platen side plates.
- (3) Lift platen mechanism from typing unit.
- (4) To replace platen mechanism, reverse the procedure used to remove it.

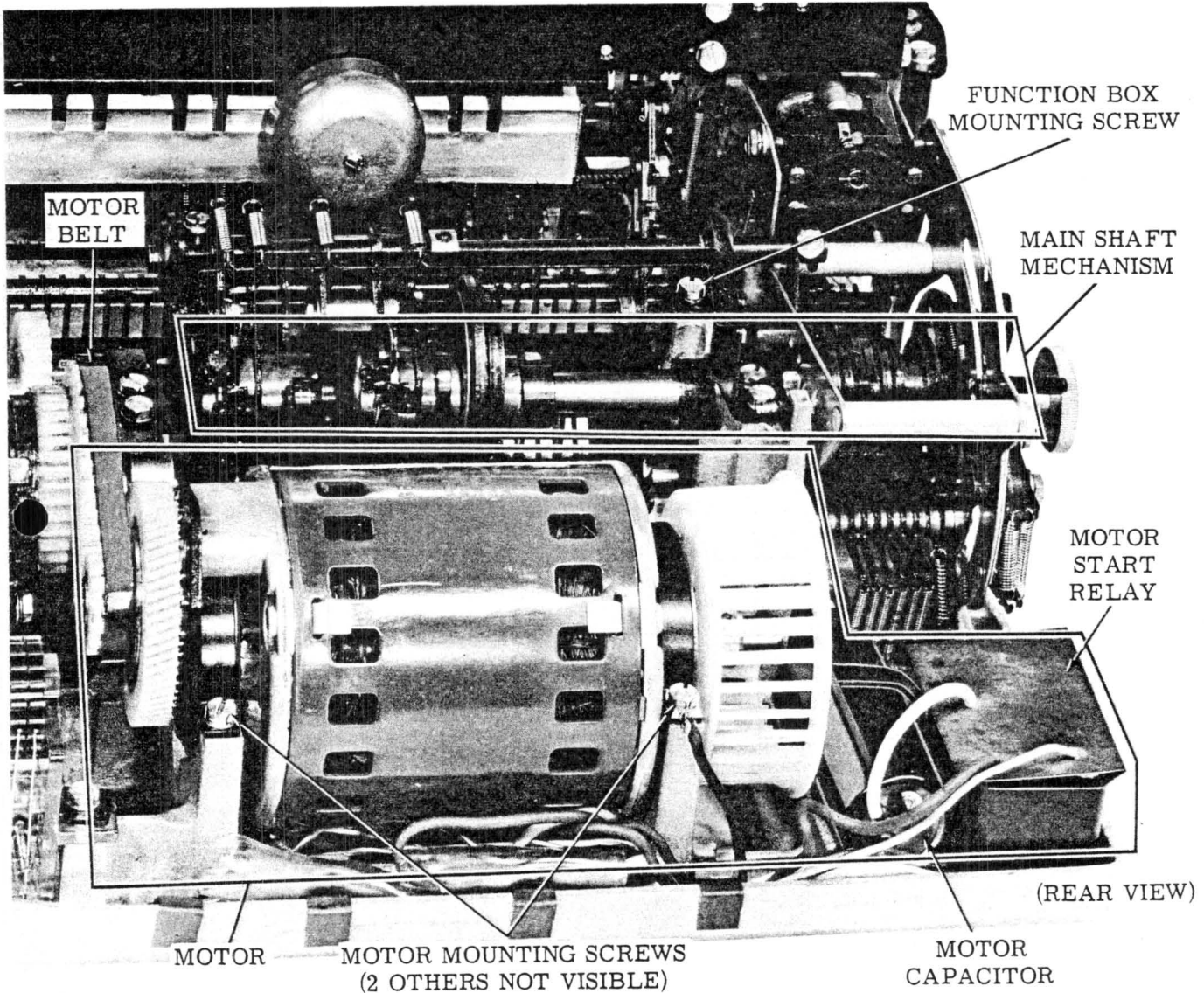

Figure 7 - Typing Unit

(b) To remove form-out mechanism, proceed as follows:

Note: Reference Figures 3 and 8.

(1) With the typing unit removed from subbase, remove the TP181242 mounting screw which secures the TP180980 brush holder.

(2) Remove brush holder and brush.

Note: On Automatic Send-Receive Teletypewriter Sets, remove the front TP152893 and loosen the rear TP152893

contact bracket mounting screws which secure the tape reader feed magnet contact assembly to the typing unit. Rotate the tape reader feed magnet contact assembly out of the way clockwise, as viewed from the right.

(3) Loosen TP151721 and two TP180989 distributor disc mounting screws and pull the distributor disc out of the way.

Note: It is not necessary to remove wires from the distributor disc.

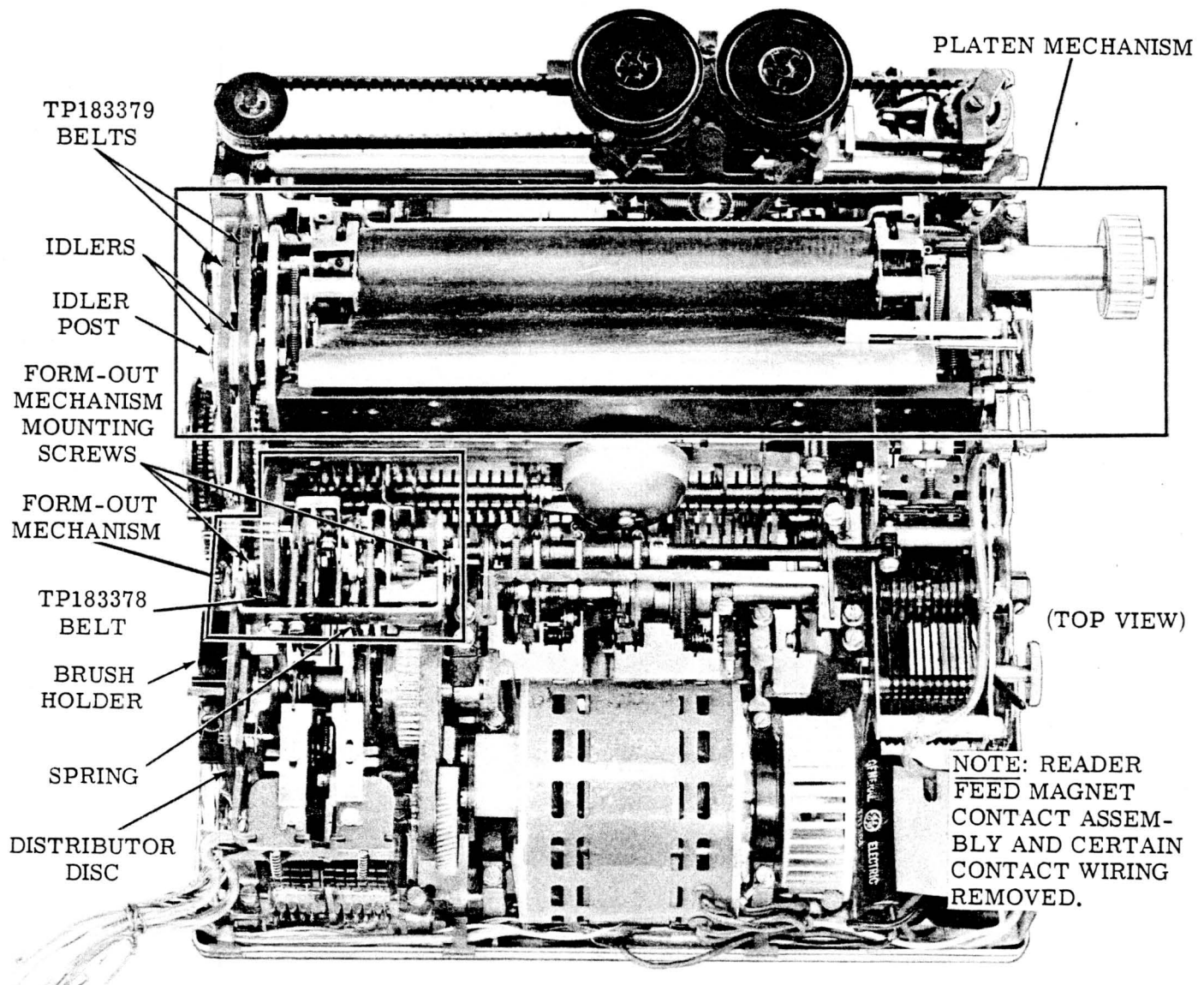

Figure 8 - Typing Unit

- (4) Loosen TP3598 nut on TP183351 idler post. Back off two TP183341 idlers.
- (5) Slip two TP183379 belts off sprockets.
- (6) Loosen three TP151630 form-out mechanism mounting screws.
- (7) Slip TP183378 belt off main shaft sprocket.
- (8) Disengage TP90891 spring from form-out latchlever assembly.
- (9) Gently work form-out mechanism upward and remove it.
- (10) To replace the form-out mechanism, reverse the procedure used to remove it.

Note: When tightening the three distributor disc mounting screws, be sure that the longer edges of TP180676 speed nuts are horizontal with the base casting.

32 AND 33 CALL CONTROL UNIT  
 PRINCIPLES OF OPERATION

CONTENTS	PAGE	CONTENTS	PAGE
1. GENERAL . . . . .	2	3. CALL CONTROL UNIT - BELL SYSTEM SWITCHED NETWORK SERVICE . . . . .	25
2. CALL CONTROL UNIT - WESTERN UNION "TELEX" SERVICE . . . . .	3	OPERATION . . . . .	25
OPERATION . . . . .	3	A. General . . . . .	25
A. General . . . . .	3	B. Power Requirements . . . . .	26
B. Neutral Signaling Condition . . . . .	3	PROGRESS OF A CALL . . . . .	26
C. Polar Signaling Condition . . . . .	5	DISCONNECTING A CALL . . . . .	26
POWER SUPPLY . . . . .	5	ANSWERING A CALL . . . . .	27
LOCAL-REMOTE CONTROL CIRCUITS . . . . .	6	A. Manual Answering . . . . .	27
A. General . . . . .	6	B. Automatic Answering . . . . .	27
B. Proceed-to-Dial Circuit . . . . .	6	LOCAL MODE . . . . .	27
C. Connect Circuit . . . . .	7	"OUT OF SERV." SWITCH . . . . .	27
D. Local Circuit . . . . .	9	LOW-PAPER ALARM . . . . .	28
E. Circuit Interconnections . . . . .	10	RESTRAIN LAMP . . . . .	28
F. Idle Line Condition . . . . .	11	TEST MODE . . . . .	28
G. Initiating a Call . . . . .	11	SIGNAL GENERATION . . . . .	29
H. Connection . . . . .	13	SELECTOR MAGNET DRIVER . . . . .	29
I. Disconnect . . . . .	14	A. General . . . . .	29
J. Local Off-Line Operation . . . . .	14	B. Circuit Description . . . . .	29
SELECTOR MAGNET DRIVER . . . . .	14	SPEAKER AMPLIFIER SYSTEM . . . . .	30
MOTOR DELAY TIMER . . . . .	15	DIALER MECHANISMS . . . . .	31
POLAR ADAPTER . . . . .	17	A. Pulsing Rotary Dialer . . . . .	31
A. General . . . . .	17	B. Pulsing Card Dialer (40A Dialer) . . . . .	31
B. Receiving Polar Relay . . . . .	17	C. Pulsing Card Dialer (41A Dialer) . . . . .	32
C. Sending Polar Relay . . . . .	18	D. TOUCH-TONE Dialer . . . . .	33
D. Connect Control Timer . . . . .	18	E. TOUCH-TONE and Card Dialer . . . . .	35
E. Current Amplifier . . . . .	21	4. CALL CONTROL UNIT - PRIVATE WIRE SERVICE . . . . .	36
F. Circuit Interconnections . . . . .	21	OPERATION . . . . .	36
G. Idle Line Condition . . . . .	21	POWER SWITCH . . . . .	36
H. Initiating a Call . . . . .	21		
I. Proceed-to-Dial . . . . .	24		
J. Dialing . . . . .	24		
K. Call Connection . . . . .	24		
L. Remote Connection . . . . .	24		
M. Call Disconnect . . . . .	25		
N. Remote Disconnect . . . . .	25		
O. Local Off-Line Operation . . . . .	25		

CONTENTS	PAGE
5. CALL CONTROL UNIT — CIRCUIT SWITCHING SERVICE . . . . .	38
OPERATION . . . . .	38
A. General . . . . .	38
B. Idle Signal Line . . . . .	38
C. Request Circuit . . . . .	38
D. Connect Circuit . . . . .	38
E. Disconnect Circuit . . . . .	38
F. Remote Disconnect Circuit. . . . .	38
G. Busy Signal . . . . .	38
H. Local Circuit. . . . .	39
ANALYSIS OF CIRCUITS . . . . .	39
A. Selector Magnet Driver . . . . .	39
B. Motor Delay Timer. . . . .	39
C. Polar Adapter . . . . .	39
D. Request Circuit . . . . .	39
E. Connect Circuit . . . . .	40
F. Local Circuit. . . . .	41
G. Circuit Interconnections . . . . .	41
H. Idle Line Condition. . . . .	42
I. Initiating a Call . . . . .	42
J. Call Connection . . . . .	43
K. Remote Connection. . . . .	43
L. Call Disconnect . . . . .	44
M. Remote Disconnect. . . . .	44
N. Local Off Line Operation. . . . .	45

## 1. GENERAL

1.01 This section is reissued to add coverage of the circuit switching call control unit. Since all changes are in 1.01, 1.06, and 5.01 through 5.52, marginal arrows are omitted.

1 The function of a call control unit is to couple a teletypewriter either to telegraph networks or, through a data set, to telephone networks. In some applications, the call control unit provides facilities for initiating, accepting, controlling, and completing calls; while in others, it acts as a connecting device only.

1.03 The call control unit used in Western Union TELEX service operates over short and intermediate length telegraph loops using neutral signaling or over longer loops with polar signaling when modified with proper polar-to-neutral converting circuitry. It includes a power supply, local-remote control circuits, a selector magnet driver circuit, and a motor delay timer circuit. Paragraphs 2.01 to 2.13 outline in general terms the call control unit's overall operation. Paragraphs 2.14

through 2.48 explain its detailed operation. The applicable schematic wiring diagram is 4779WD.

1.04 The call control unit is used in Bell System switched network service. When it is connected with the appropriate data set, it is connected with conventional telephone central offices having the required routing and message accounting equipment. These are generally the same offices and equipment serving telephone customers in the area. Direct current signals are used for both originating and terminating traffic—providing the same conditions as for conventional local telephone set operation. The dial on the call control unit, for initiation of call connections, may be either a dc pulsing or a multifrequency (MF) tone device. Also included in the call control unit are ringing or tone sounding apparatus for alerting the called party. Paragraphs 3.01 through 3.06 outline in general terms the call control unit's overall operation. Paragraphs 3.08 through 3.32 explain its detailed operation. The principal applicable schematic wiring diagram is 5918WD. For additional wiring information, see the pertinent wiring diagrams, associated with the call control unit or, when provided, the appropriate section.

1.05 The call control unit used in private wire service operates over short or intermediate length telegraph loops using neutral dc signaling. It includes a power supply, a selector magnet driver circuit and a power switch. Paragraphs 4.01 through 4.03 describe the call control unit generally, and paragraph 4.04 through 4.07 explain in detail its only manual control—the power switch. For wiring information see either 6353WD or 6355WD. For further wiring information see wiring diagram(s) associated with the particular call control unit or (when provided) appropriate section.

1.06 The call control unit used in a circuit switching network operates over short and intermediate length telegraph loops using neutral signaling or over longer loops with polar signaling when modified with proper polar-to-neutral converting circuitry. It differs from the call control unit used in Western Union TELEX service primarily in the call originating circuitry. Paragraphs 5.01 through 5.10 outline the unit's overall operation. Paragraphs 5.11 through 5.52 explain its operation in detail. The applicable wiring diagrams are 7227WD, 7267WD, and 6481WD.

Note: This unit can also be used in 35 equipment for certain circuit switching applications.

## 2. CALL CONTROL UNIT - WESTERN UNION "TELEX" SERVICE

### OPERATION

#### A. General

2.01 A selector magnet driver circuit delivers marking signals of 0.500 ampere and spacing signals of essentially 0 ampere to the associated selector magnet. The signals trigger the selector magnet driver circuit at about half the current level for normal (0.060 ampere mark) neutral input signals. In teletypewriters modified for polar operation, the signal is applied to polar-to-neutral converting circuits and then to the selector magnet driver.

2.02 The operator's controls, used for originating calls, consists of a set of pushbutton keys and a telephone-type dial:

(a) There are four translucent, nonlocking pushbuttons. An illuminating lamp associated with each pushbutton is energized under the operating conditions described in the following paragraphs, except that the START lamp is a spare and does not light.

(b) The dial, a conventional telephone-type operates normally closed bifurcated pulsing contacts that open and close to send dialing pulses during the dial run-down interval. The pulses are produced at a rate of ten per second with the contacts open for  $0.061 \pm 0.003$  second during each pulse interval. A pair of normally open off-normal contacts close when the dial wheel is rotated from its idle position. These contacts provide a steady mark current to "blind" the selector when dialing is undertaken. This prevents the printing of spurious characters if dialing is necessary when in the connected condition as in multi address calling.

#### B. Neutral Signaling Condition

2.03 In the idle condition, with the motor and typing unit stopped and visual indicators de-energized, there is a positive current of 0.005 ampere in the telegraph loop. When the calling station operator depresses the START pushbutton, it causes the shunting of a major portion of the loop resistance, and the loop current increases to 0.060 ampere. The START pushbutton must be held in the depressed position, while switching apparatus in the telegraph exchange is made available. When the circuit is ready, the telegraph exchange interrupts the

0.060 ampere loop current for about 0.025 second. This "proceed-to-dial" signal causes the DIAL lamp to be illuminated at the calling station, and it locks in the shunt to the loop resistance so that the operator may now release the START pushbutton and proceed to dial the number of the called station. Rotation of the dial transmits signals consisting of no current for 0.06 second followed by full current (0.060 ampere) for 0.04 second during each dial pulse interval. When dialing is completed, the exchange furnishes the connection and signifies this by reversing the telegraph loop current from positive to negative which causes the typing unit motor to start and the CONN lamp to light. Message transmission can now be exchanged between the connected teletypewriters. The line signals are 0.060 ampere marking and zero current spacing.

2.04 If the distant called station is busy or disabled at the time of a call, the local telegraph exchange reverses the local loop current from positive to negative for about 0.2 second and then causes it to revert to positive current again. This causes the local motor to start and the CONN lamp to light momentarily, but they then both turn off. The teletypewriter returns to the idle condition as the positive current is detected.

2.05 The local telegraph exchange responds to an incoming call by reversing the idle signal loop from positive to negative current. At the local station, the CONN lamp is illuminated, and the motor is turned on as the shunt to the loop resistance is applied in response to the current change. Message transmission can now take place with unattended service at the receiving station.

2.06 Following completion of traffic a disconnect can be originated from either the calling or the called station. Holding the STOP pushbutton depressed causes the line to go open (zero current). In approximately 3 seconds the local exchange causes the connection to the distant station to be broken, and it reverses the current in the local loop so that positive current flows—limited by the local station loop resistance. This turns off the motor and extinguishes the CONN lamp. The STOP pushbutton is released after the CONN lamp goes out. The original idle condition is now restored. When a disconnect is initiated from a remote station, the local exchange recognizes the open line interval and breaks the connection. The loop current is reversed back to positive, and the local station is returned to the idle condition as stated above.

Figure 1 - Power Input Circuit

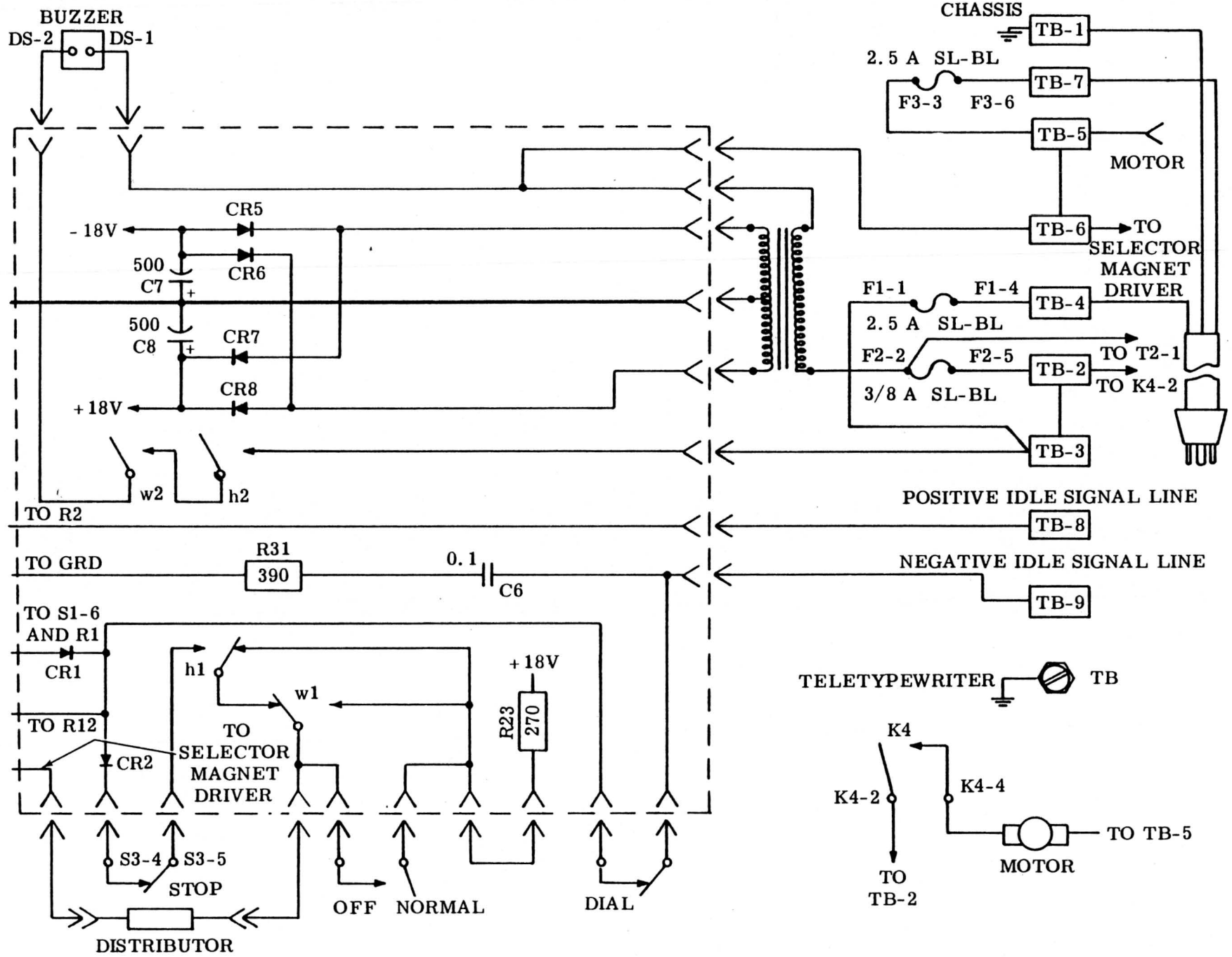

2.07 Local operation is provided by depressing the LOCAL pushbutton until the LOCAL lamp is turned on. This places the teletypewriter in an off-line operating condition for copy preparation, practice, or maintenance purposes. To return to the idle condition, the STOP pushbutton is held operated until the lamp is extinguished, or a call can be initiated by depressing the START pushbutton directly. If a call is received while the teletypewriter is in the local condition, the buzzer will sound for an interval of 2.6 seconds, and the teletypewriter will automatically shift over to the call-connected condition with the CONN lamp illuminated.

### C. Polar Signaling Condition

2.08 Call control units that are modified for polar operation respond to and transmit polar telegraph signals on separate receiving and sending legs extending to the telegraph exchange facilities. The operating conditions and sequence are similar to that for neutral signaling.

2.09 In the idle condition the sending and receiving legs each have from 0.015 to 0.040 ampere positive current flowing. The sending leg current is supplied by the call control unit, and the receiving leg current is supplied by the central exchange. At the local station the polar adapter interconnects the legs with the neutral signaling control and teletypewriter circuitry. Operation of the START pushbutton causes the current in the sending leg to reverse to a negative polarity with a value equal to the positive current formerly applied (0.015 to 0.040 ampere). The telegraph exchange responds by reversing the current to negative on the receiving leg for 0.025 second. This causes illumination of the DIAL lamp at which time the START pushbutton should be released. The dialing signals go out over the sending leg in polar form with each pulse interval consisting of 0.06 second of positive current followed by 0.04 second of negative current. When the connection is completed, the exchange reverses the polarity of the receiving leg from positive to negative current. After 0.08 second of this reversal, the call control unit causes the motor to turn on, and the CONN lamp to be illuminated. Traffic can now be exchanged. Each station is arranged to record its transmitted copy. Transmitted and received signals consist of positive current for space and negative current for mark on both signal legs.

2.10 When receiving an incoming call, the local exchange reverses the receiving leg current from positive to negative. The local call control unit, after 0.08 second of negative current, turns on the motor and the CONN light and causes the sending leg current to be reversed from positive to negative.

2.11 If the distant station that is called is busy, it will result in the momentary application of negative current to the local receiving leg followed by a return to a continuous positive current. The motor may run briefly, but the teletypewriter will be quickly placed back into the idle condition.

2.12 In effecting a disconnect, operation of the STOP pushbutton causes the transmission of positive current on the sending leg. The exchange will then reverse the current on the receiving leg to positive as it breaks connection to the distant station. The call control unit detects the positive current. After 1.3 seconds it turns the motor and CONN lamp off as it applies a steady positive current to the sending leg and restores the teletypewriter to the idle condition. If the disconnect is initiated at the distant teletypewriter, the positive current disconnect signal, when applied to the local receiving leg, causes the local teletypewriter to go into the idle condition after 1.3 seconds, and the sending loop becomes positive again.

2.13 For local operation the internal conditions are the same as for neutral signaling. Externally, the signal legs remain on positive current unless a call is received. When a call is received, a negative current on the receiving leg for 0.08 second causes the buzzer to sound for 2.6 seconds. Following the buzzer sound, teletypewriter shifts to the call-connected condition.

### POWER SUPPLY

2.14 Figure 1 illustrates a schematic diagram of the power input circuit.

2.15 A fused power supply operates on 115-volts ac  $\pm 10\%$  at 60 cps and a power input of 12 watts. It floats with respect to the input line; that is, it is not at earth ground. Therefore, the center tap of the transformer is  $\pm 120$  volts to earth ground in neutral signaling. The polar adapter, on teletypewriters equipped for polar operation, also contains a power supply. When operating on a polar line, this power supply, as well as that of the call control unit, is operated with ground to earth.

## LOCAL-REMOTE CONTROL CIRCUITS

## A. General

2.16 The local-remote control is a printed card assembly consisting of three circuits that accomplish the switching called for by the input line or operation of the call control unit pushbuttons. These circuits are the proceed-to-dial, connect, and local circuits. They are essentially binaries (flip-flops) that have been modified to perform their function. All the circuits are protected with a diode arc suppressor against transients and voltage pulses generated by their associated relays. A negative voltage, generated at the collector of a transistor, will be shorted through the diode to resistor R27. The transient will be developed across R27 and the lamp associated with relay. The diodes performing this function are CR10, CR12, and CR19. The circuits are also protected from transient noise induced into them from leads in the cable to the dial and key and lamp assembly. A low-pass filter or delay network of the RC type is placed in a feedback loop in each binary. The delay network slows the response time of the associated binary. This reduces its susceptibility to noise. These delay networks are made up of R10 and C3, R21 and C4, and R39 and C11. The signal line inputs are filtered against spurious noise occurring on the signal line. There are two of these filters, both of the RC type. In the proceed-to-dial circuit, the delay network (R5 and C1) provides 0.001 second delay. In the connect circuit, the delay network (R12 and C2) provides a 0.02 second delay. The RC network, consisting of R31 and C6, in the 240-volt signal line acts as an arc suppressor to protect associated contacts.

## B. Proceed-to-Dial Circuit

2.17 Figure 2 illustrates a schematic diagram of the proceed-to-dial circuit.

2.18 This circuit consists of a binary with a line input amplifier. The amplifier consists of transistor Q1 and associated components, and the binary consists of transistors Q2, Q3, and associated components. The amplifier is connected to the binary through a low-pass filter or delay network (R5 and C1) which suppresses signal line noise. Input to the binary from the filter through R6 will turn on the proceed-to-dial circuit. Two other control inputs turn off the proceed-to-dial circuit. One of these is through resistor R15, and the other is through

pushbutton contact S3-1. Operation of the transistors in the proceed to-dial-circuit is as follows:

(a) When transistor Q2 is in conduction, its collector is near neutral potential. Current will flow through Q2, R11, S3-1, S3-2, and R27. Current will also flow from +18 volts through R8 and CR9 to the collector of Q2. The base of Q3 will be held +0.8 volt with respect to the collector of Q2 due to the current flow through CR9. The base of Q3 will, therefore, be slightly positive with respect to neutral, and Q3 will be turned off. With Q3 turned off, its collector will be negative, and base current to Q2 will be supplied through the low-pass filter consisting of R9, R10, and C3 which holds Q2 in conduction.

(b) When transistor Q3 is in conduction, the proceed-to-dial circuit is on, and the collector is near neutral. Current flows through Q3, K1, DS-2, and R27. Since the collector Q3 is near neutral, current flow through R7, R9, and R10 produces a positive potential at the base of Q2 which holds Q2 off. With Q2 off, base current for Q3 will flow through CR9, R11, S3-1, S3-2, and R27 holding Q3 in conduction.

(c) If an input current in excess of 0.002 ampere flows from TB-8 across CR4 to neutral, a +0.8 volt is developed across CR4. This positive potential holds Q1 in conduction and its collector near neutral potential. Neutral potential at this collector has no effect on the base of Q2 because of isolation provided by R5 and R6. If the input current falls below 0.002 ampere, a -0.8 volt is developed across CR4 due to the flow of current through R3, R2, and CR4. This potential turns off Q1, and its collector becomes positive. Current flows through R4 and R5 to charge C1 toward a +18 volts. When sufficient voltage is developed across C1, the base of Q2 will be back-biased through R6. Transistor Q2 turns off, and Q3 turns on. The proceed-to-dial circuit is now on. Back-bias to the base of Q2 is supplied by the voltage divider R7, R9, and R10 so that the positive potential applied across R6 is no longer required to hold Q2 off. If more than 0.002 ampere begins to flow across CR4 again, Q1 will turn on, and its collector will go to neutral, but this will have no effect on the base of Q2.



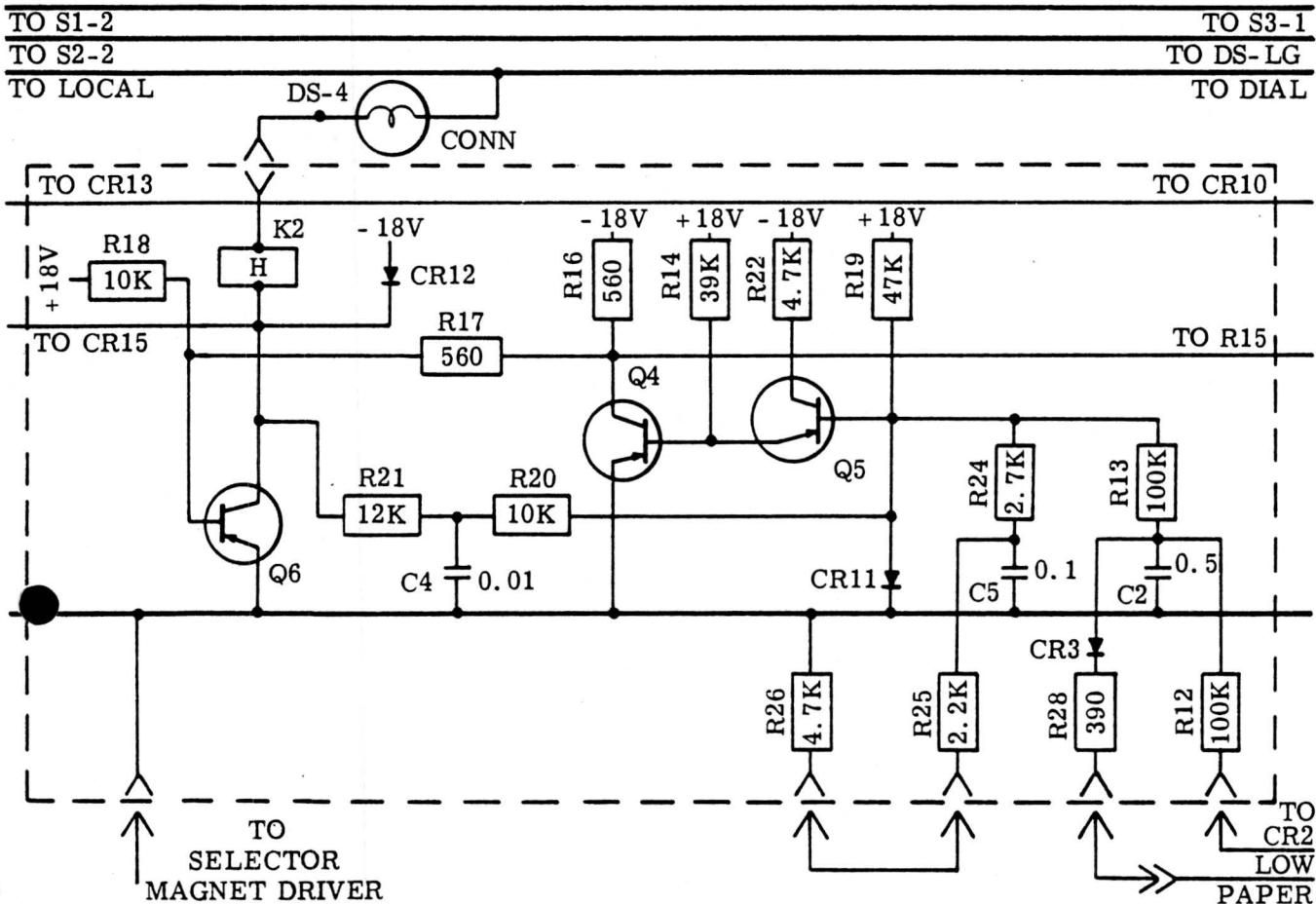

Figure 3 - Connect Circuit

collector of Q6 will then be negative, and the base of Q5 will be held slightly negative through R20 and R21. Since Q5 is an emitter follower, its emitter will be held at the same potential as its base. With its emitter a negative potential, Q4 will be held on.

(b) When the connect circuit is on, Q6 is in conduction, and its collector is near neutral. The voltage divider R19, R20, and R21 holds the base of Q5 and therefore the emitter, positive. With the emitter of Q5 positive, the base of Q4 will be back-biased, and Q4 will be off. The collector of Q4 will then be negative. Base current for Q6 will flow through R16 and R17 holding the connect circuit on.

(c) To control the connect circuit a high voltage must be developed at the junction of CR1 and CR2. This voltage will be approximately  $\pm 200$  volts. If a +200 volt signal is applied at this point, the base of Q5 will be biased positive, and Q4 will turn off. Q6 will turn on. If a -200 volt signal is applied, the

base of Q5 will be biased negative, and Q4 will turn on. Q6 will turn off. An input signal at or near neutral will have no effect upon the connect circuit, and it will remain in its prior state.

(d) The base of Q5 is protected against excessively high voltages by transistor operation or by CR11. If a -200 volt signal is present, the voltage on the base of Q5 will fall and force its emitter to follow. When the emitter of Q5 becomes negative with respect to ground, Q4 will turn on. With Q4 in conduction, its base potential is held close to the emitter potential. Therefore, the base cannot go more negative than approximately -0.4 volt. This action also holds the base voltage of Q4 within -0.4 volt of its emitter. The base voltage of Q5, then, cannot become more negative than approximately -0.8 volt. If a +200 volt signal is present at the input, the base of Q5 will start to become positive. The diode CR11 is forward-biased to positive base voltages. It will limit the voltage on the base of Q5 to approximately +0.8 volt. There-

fore, under the severest input conditions, a voltage swing of more than  $\pm 0.8$  volt is not expected.

(e) Resistors R24, R25, R26, and capacitor C5 are used where a polar converter is employed. As they are shown connected in 4779WD, they have no effect on the operation of this circuit.

D. Local Circuit

2.21 Figure 4 illustrates a schematic diagram of the local circuit.

2.22 A binary and a unijunction transistor timer make up the local circuit. Binary operation of Q8 and Q9 is the same as that of the proceed-to-dial circuit. There are four input controls available.

(a) Operation of the LOCAL pushbutton turns on the local circuit (Q9 on). When contact S2-1 is closed, base current is supplied to Q9 through R37 and R38, and Q9 will turn on. Q8 will turn off. If the anode of either CR13 or CR14 is neutral, current flowing through R38 will flow through one of the diodes and not reach the base of Q9. These two diodes allow the local circuit to be turned on only when the proceed-to-dial and connect circuits are off.

(b) The local circuit can be turned off by operation of either the START or the STOP pushbutton. When the local circuit is on, the base current for Q9 flows through contacts S1-1 of the START pushbutton and contact S3-1 of the STOP pushbutton. Since the contacts of the two pushbuttons are in

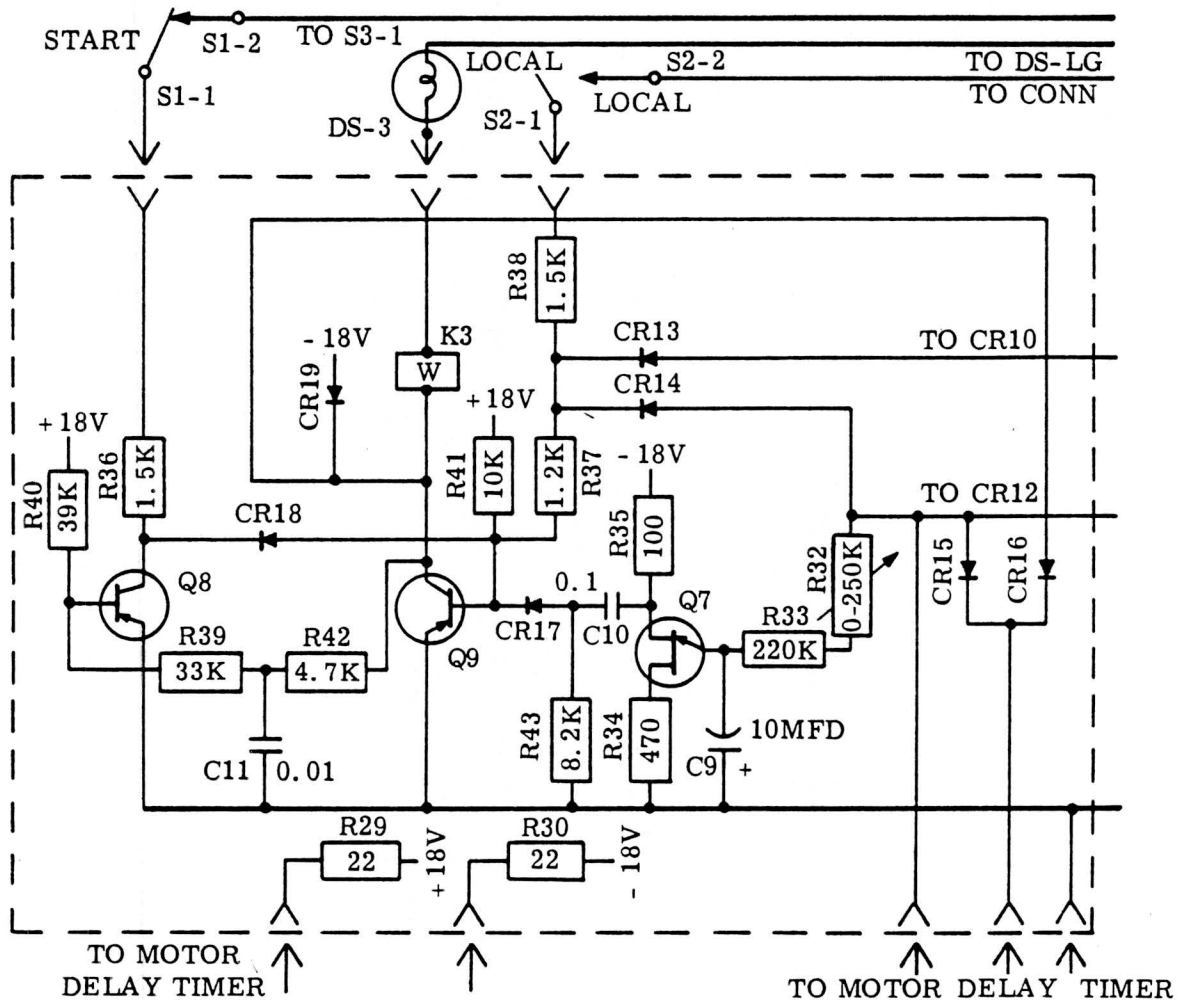

Figure 4 - Local Circuit



(b) The proceed-to-dial circuit can be turned off in two ways: If the STOP pushbutton is operated or the connect circuit operates, the proceed-to-dial circuit will turn off. Local control is provided by operation of the STOP pushbutton, while the connect circuit provides automatic control initiated by the exchange.

2.25 The connect circuit is controlled only by the line and, therefore, has only one input. This input is from line sensing and control as shown in Figure 5.

#### 2.26 Local Circuit:

(a) To turn the local circuit on, three conditions must be satisfied:

(1) The proceed-to-dial and connect circuits must be off, and the LOCAL pushbutton must be depressed.

(2) The input of both the proceed-to-dial and the connect circuit protect against accidental operation of the local circuit which would otherwise cause an automatic disconnect.

(b) The local circuit is turned off by operating the STOP pushbutton, the START pushbutton, or the 2.3-second timer. The START and STOP pushbuttons provide local control of the circuit, while the 2.3-second timer provides automatic control. The 2.3-second timer is controlled by the connect circuit which is, in turn, controlled by the line. The 2.3-second timer continues to oscillate as long as the connect circuit is on, but only the first timing pulse is required to turn off the local circuit.

(c) Each of the above three circuits has an input to the line sensing and control. The inputs are in the form of relay contacts which switch the line through the proper internal path in the local and remote control assembly. When either the connect or local circuit is on, a motor control relay is operated. The contacts of the relay are used to turn on the motor of the associated typing unit.

#### F. Idle Line Condition

2.27 Figure 6 is the first of two schematic diagrams which illustrates the local-remote control circuit. It shows the current flow during the idle line condition.

2.28 In this state all relays and lamps are off.

This requires that transistors Q3, Q6, and Q9 be off and that Q2, Q4, and Q8 be in conduction. The output transistor of the motor delay timer is off, and the selector magnet driver is marking.

(a) The signal loop is a 240-volt source with 4000 ohms in series. In the idle condition the local-remote control offers 43,800 ohms of local resistance to the signal loop. The flow of loop current in this condition is shown in Figure 6. Current flows from TB8, the positive idle terminal, across CR4, through R1 and CR1 in parallel with the base emitter junction of Q4 and Q5, R13 and R12. From this point, current flows through the dial pulse contacts to terminal TB9.

(b) Loop current develops a positive potential at (A) in Figure 6 holding transistor Q1 on. The collector of Q1 is shorted to ground through contacts S1-4 and S1-5 on the START pushbutton. Therefore, no signal is developed at the collector unless the START pushbutton is depressed. Loop current develops about -200 volts with respect to neutral at point (B). This potential holds Q4 in conduction and the connect circuit off (Q6 off).

(c) The selector magnet driver is supplied 0.060 ampere locally to hold the selector magnet. This current is supplied through R23 and flows through contacts "h1" and "w1," the distributor and the selector magnet driver to neutral.

#### G. Initiating a Call

2.29 A call can be initiated with the teletypewriter in either idle or local condition by depressing the START pushbutton. This performs three functions: Contacts S1-1 and S1-2 open and turn off the local circuit. Contacts S1-4 and S1-5 open and remove the short from the collector of Q1. The collector will remain at ground since more than 0.002 ampere is flowing through CR4. Contacts S1-6 and S1-5 close, shorting the local loop resistance which allows the loop current to rise to 0.060 ampere. The loop current now flows from TB8, through CR4, contact S1-5, contact S1-6, CR1, and the dial impulse contacts to TB9. Shorting out the local loop resistance causes the voltage at point (A) to rise neutral. This has no effect on the state of the connect circuit.

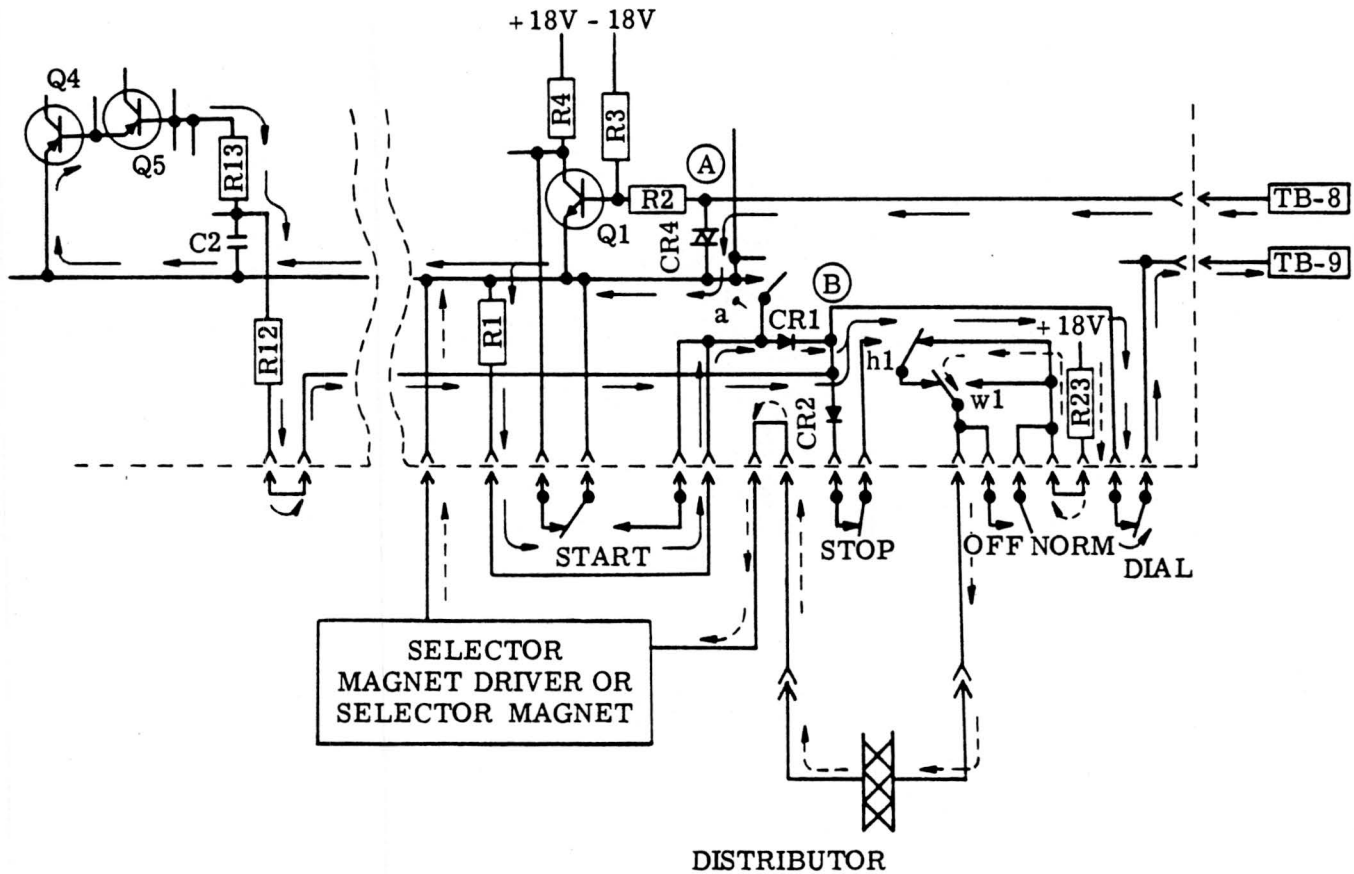

Figure 6 - Local-Remote Control Circuit—Current Flow (Idle)

(a) Proceed-to-dial: When the START push-button is depressed, a proceed-to-dial pulse will cause the collector of Q1 to go positive and, in turn, operate the proceed-to-dial circuit (turn on Q3). With Q3 in conduction, current will flow through the A(K1) relay and the DIAL lamp. This causes both of them to be operated. The normally open contact "a" of the A(K1) relay will operate the short contacts S1-6 and S1-5 of the START pushbutton. Loop current now flows from TB8, through CR4, contact "a," CR1, and the dial pulse contacts to terminal TB9.

(1) With Q3 in conduction, its collector will be near neutral. This holds the junction of R37 and R38 in the local circuit near neutral through CR13 as the LOCAL pushbutton is depressed. The local circuit cannot now be turned on. The proceed-to-dial circuit may be turned off by operating the STOP pushbutton. Contacts S3-1 and S3-2 will open and cause Q3 to turn off as described earlier. With Q3 turned off the teletypewriter will revert

to the idle line condition, and the current loop will be as shown in Figure 6.

(2) In initiating a call, if the START push-button is released at any time before the proceed-to-dial pulse is given by the exchange, the teletypewriter will revert to the idle line condition. The exchange requires a short time to reset after the START pushbutton is released early and should not be reoperated for a few seconds.

(b) Dialing: The dial is in the signal loop at all times, but it may be used to transmit information to the exchange only during the proceed-to-dial and the connect conditions. Since the dial impulse contacts are in series with the loop, operation of the dial will completely break loop current. In order to prevent damage to the dial contacts, an arc suppressor, R31 and C6, is placed across the contacts.

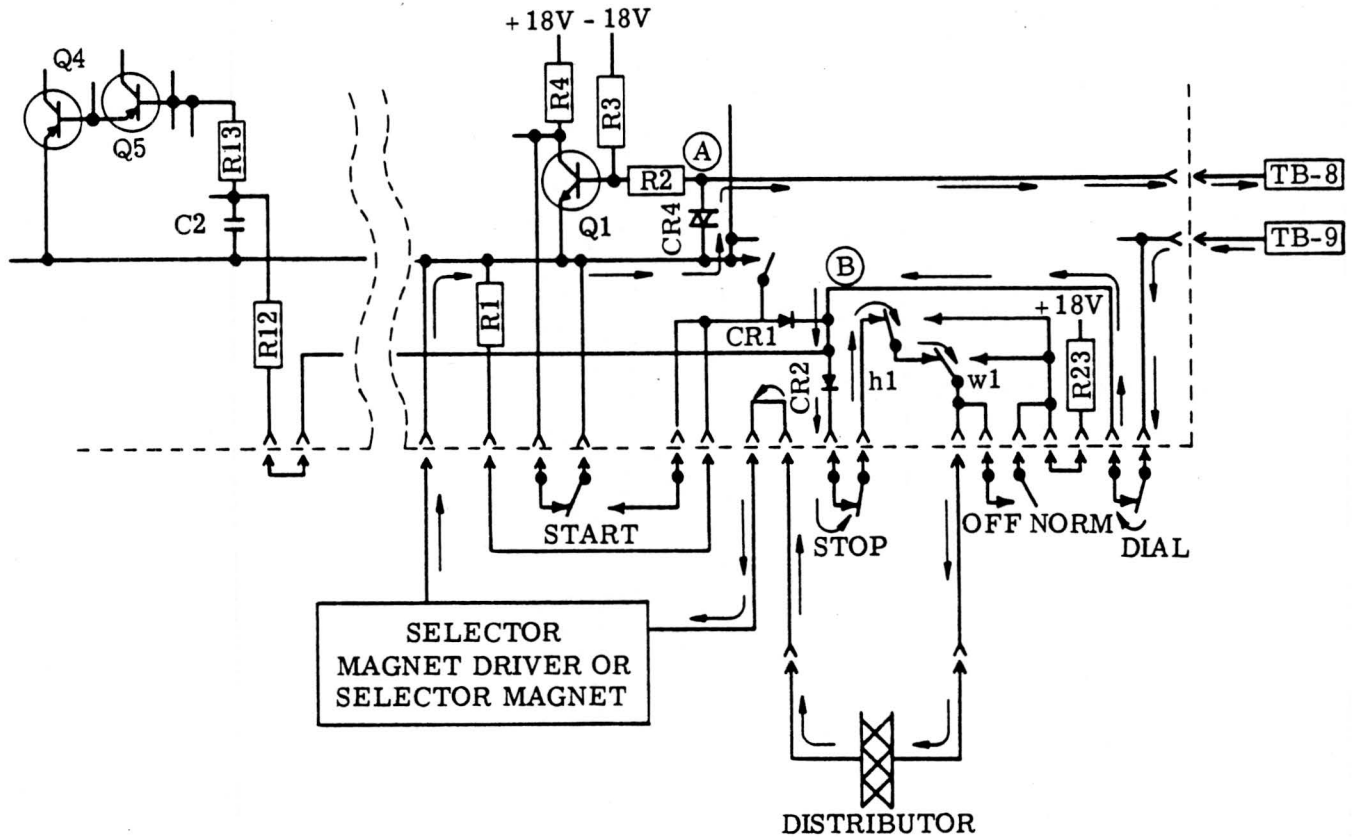

Figure 7 - Local-Remote Control Circuit—Current Flow (Local Connection)

#### H. Connection

2.30 Figure 7 is the second of two schematic diagrams which illustrates the local-remote control circuit. It shows the current flow during local connection.

2.31 Local Connection: If a call is initiated locally, current in the loop will be 0.060 ampere from TB8 to TB9 through the path described in 2.28 before connection. When the loop polarity is reversed by the exchange, current flow is from TB9 to TB8. Diode CR1 becomes reverse-biased and stops current flow except through R12 and R13. This current flow turns off Q4 and turns on the connect circuit (turns on Q6). With Q6 in conduction, the H(K2) relay will operate and the CONN lamp will light. The transfer contacts "h1" of the H(K2) relay will switch and allow loop current of 0.060 ampere to flow through the distributor and selector magnet driver as shown in Figure 7. Loop current now flows from TB9, through the dial pulse contacts, CR2, the contacts of "h1" and "w1," the distributor, the selector magnet driver

and CR4 to TB8. Current will also flow through CR15 to operate the motor delay timer and, in turn, the motor control relay M when Q6 is in conduction. Contacts K4 will close and start the motor. Q4 is cut off, and its collector is negative. Feedback from the collector of Q4 to the base of Q2 through R15 will turn off the proceed-to-dial circuit. The A(K1) relay will release, and the DIAL lamp will go out. The "a" contact will open, but it does not have any effect upon the loop current flow, since it is not now in the current loop. The junction of R37 and R38 is held near neutral from the collector of Q6 through CR14, preventing local circuit operation.

2.32 Remote Connection: On an incoming call, the teletypewriter may be connected remotely while in the idle line or local conditions. The loop path is shown in Figure 6 for both of these conditions. The incoming call causes the exchange to reverse the loop polarity. This causes the potential at the junction of CR1 and CR2 to change from -200 volts to approximately +200 volts. The potential causes the connect circuit to operate as described in 2.31.

2.33 Low-Paper Circuit: If the paper in a teletypewriter has become low and the low-paper contacts operate, the junction of R12 and R13 will not be allowed to become positive. Q4 cannot be turned off, and a connection cannot be made. If low paper occurs during a call, the teletypewriter will remain in the connected state, since zero potential at the junction of R12 and R13 will not effect the connect circuit. A disconnect will occur in the normal manner, since CR3 will be back-biased to a negative potential at the junction of R12 and R13. If a call is initiated locally with a low-paper condition, the normal sequence of events will occur until a connection is attempted. When the exchange cannot connect, it will reverse the loop polarity, and the teletypewriter will return to the idle state.

#### I. Disconnect

2.34 Local Disconnect: Operation of the STOP pushbutton while in the connect condition opens contacts S3-4 and S3-5, which are in series with the loop, and breaks the loop. When the exchange recognizes the break, it reverses the loop polarity. The reverse polarity is blocked by CR2, and current flows through CR1 along the path shown in Figure 6. At point (A) -200 volts is developed due to current flow as described in 2.27 and 2.28. This potential causes the connect circuit to turn off. The CONN lamp goes out and the H(K2) relay releases. The "h1" contacts return to the blinded condition, and the teletypewriter stops running open. The input to the motor delay timer becomes negative, and the timer will time out. After 0.55 second the motor control relay releases, and the motor will turn off. This delay allows the clutches to latch.

2.35 Remote Disconnect: The operation of the circuits and the loop paths are the same as those described in 2.32. The STOP pushbutton is not operated locally, but the signal conditions appear identical to the local-remote control.

#### J. Local Off-Line Operation

2.36 When the teletypewriter is in the idle line condition, operation of the LOCAL pushbutton will cause the local circuit to operate (Q9 turns on). If the control is in the proceed-to-dial or connect conditions, CR13 or CR14 will prevent operation of the local circuit. When the local circuit operates, the W(K3) relay operates and the LOCAL lamp will light. Contact "w1" of the W(K3) relay will short out contacts "h1" in the distributor-selector

magnet driver loop. Current to this loop will then flow through R23, "w1," the distributor, and the selector magnet driver to neutral. Current will also flow through CR16 to turn on the output transistor of the motor delay timer. The motor control relay will operate, and the motor will start. The teletypewriter is now ready for off-line operation. To return to the idle line condition, the STOP pushbutton may be depressed. Contacts S3-1 and S3-2 open and turn off the local circuit. A call may be initiated in the local condition in the usual manner. When the START pushbutton is depressed, contacts S1-1 and S1-2 open and turn off the local circuit in the same way as the STOP pushbutton.

(a) If an incoming call is received while the teletypewriter is in the local condition, the action of the circuit is the same as that described in 2.27 and 2.28. The H(K2) relay operates to shunt the line through the distributor and selector magnet driver, but this operation cannot be accomplished, since the "w1" contacts have shorted the "h1" contacts out of the circuit. Operation of the "h2" contacts will complete the 115 volt ac circuit to the buzzer causing it to sound.

(b) When the connect circuit is turned on, the collector of Q6 approaches neutral. This causes the timer to start. At the end of a 2.3 second period, a positive pulse from the timer is coupled to the base of Q9 through C10 and CR17. The pulse causes the local circuit to turn off, the LOCAL lamp to be extinguished, and the W(K3) relay to be released. The "w1" contacts short the signal loop through the distributor and selector magnet driver. The "w2" contacts open and the buzzer will turn off. The teletypewriter is now in the connect condition.

#### SELECTOR MAGNET DRIVER

2.37 Figure 8 illustrates a schematic diagram of the selector magnet driver circuit.

2.38 The selector magnet driver, combined with an external power transformer, a resistor, and a filter capacitor, provides 0.500 ampere for driving a selector magnet from a telegraph signal source of appropriate input line current. The input signals are applied through terminals no. 7 and 13, with R1 determining the switching level.

2.39 For mark input, positive current is applied to terminal no. 7, providing a

positive bias to the base of transistor Q1 that overcomes the normal negative bias supplied through R1 and stabilized by Zener diode ZD1. Q1 turns off as the increasing positive current reaches one-half of its final value. The collector of Q1 goes negative, and the drop across the collector load resistor R3 is applied to the base of Q2. This turns Q2 on. R4 provides emitter bias to Q1, and supplies a regenerative action to the transition.

2.40 The selector magnet, in series with the external resistor, is connected between the collector of Q2 at terminal no. 6 and negative battery at terminal no. 15. It supplies the load for Q2. On marks, the current through Q2 quickly rises to 0.500 ampere, as set by the external resistor, and energizes the selector magnet.

2.41 On space input, the positive input bias decreases, and Q1 is turned on at the half-line current point by negative bias through R1. The collector of Q1 rises toward zero—applying reverse-bias to Q2, turning off Q2,

and de-energizing the selector magnet. The selector magnet opposes the change in current, and it applies a transient to the collector of Q2 which is more negative than the battery potential at terminal no. 15. CR3 now conducts—passing the transient to C1 and R5 which limit the transient to a value well under the breakdown voltage of Q2 while the selector magnet energy is being dissipated.

MOTOR DELAY TIMER

2.42 Figure 9 illustrates a schematic diagram of the motor delay timer circuit.

2.43 The motor delay timer provides a means to delay motor turn-off in the teletypewriter. This allows the teletypewriter to complete its printing cycle and come to rest before the motor begins to stop. This circuit is mounted on the same circuit card assembly with the selector magnet driver, but the circuit is electrically independent of it. It is designed to drive a motor control relay connected between points no. 3 and 5 and is operated when either the connect or local circuit is on.

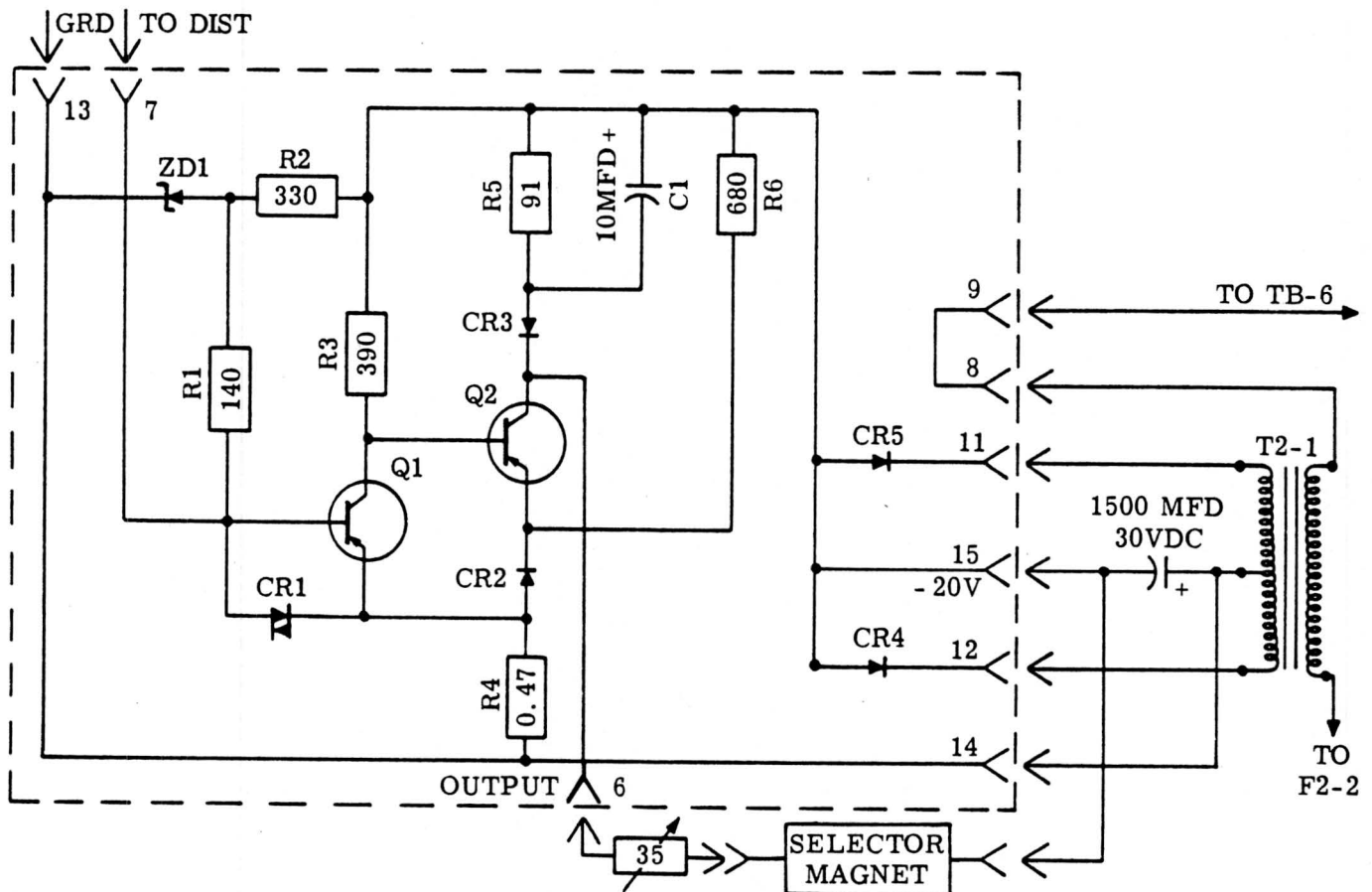

Figure 8 - Selector Magnet Driver Circuit

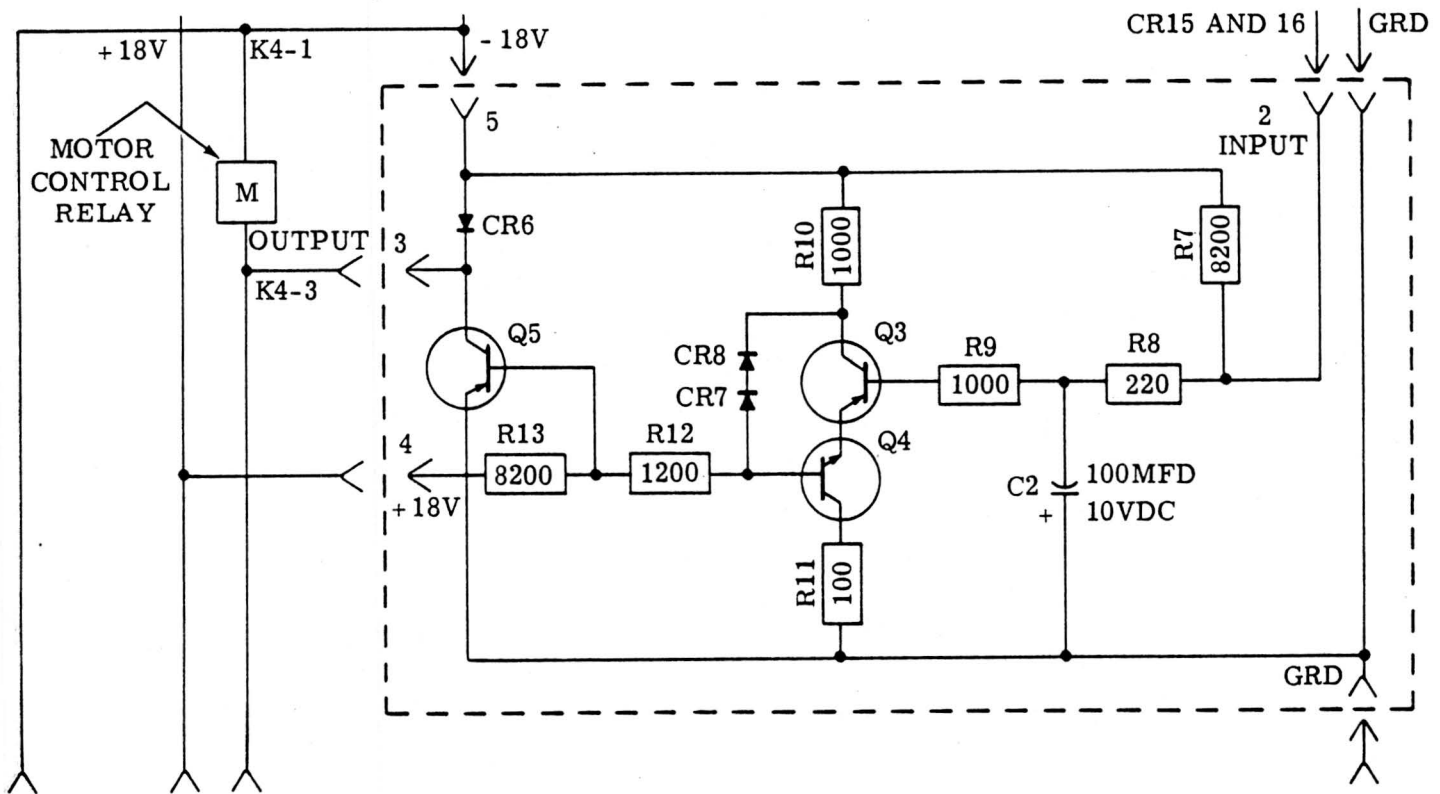

Figure 9 - Motor Delay Timer Circuit

2.44 The motor delay timer consists of a regenerative switch (Q3 and Q4) and an output driver (Q5). The input to the motor delay timer is from the collector of Q9 through diode CR16 or from the collector of Q6 through diode CR15 in the local and connect circuits of the local-remote control circuit. The diodes provide insulation between the input of the motor delay timer and the transistors of the local-remote control for negative signals. When the input of the motor delay timer at point no. 2 is grounded, the output driver will turn on immediately. When the input signal is removed, the output driver will remain in conduction for approximately 0.55 second while holding the motor control relay operated long enough to allow the teletypewriter to complete its printer cycle before turning off the motor.

2.45 When a negative input signal is applied to point no. 2, base current to Q3 will flow through R7, R8, and R9. Q4 will be held in conduction by base current flowing through R12 and R13. The collector of Q3 will be at approximately -1.6 volts. The voltage divider, R12 and R13, will hold the base of Q5 positive, and Q5 will be cut off.

2.46 If ground is now applied to the input, the base of Q3 will approach ground and become reverse biased. This turns Q3 off. The collector of Q3 will become -10.0 volts. This voltage will cause the voltage at the base and the emitter of the emitter follower Q4 to be -8.5 volts. The emitter of Q3 will be held at -8.5 volts by the emitter of Q4. This holds Q3 off. The -10.0 volts at the collector of Q3 will cause base current to flow to Q5 through CR7, CR8, and R12. Q5 will then go into conduction, and operate the external motor control relay.

2.47 If the ground input is now removed, current will flow through R7 and R8 and charge C2 toward -18 volts. After about 0.55 second the voltage on C2 reaches -8.5 volts, the voltage on the emitter of Q3, and Q3 goes into conduction with its collector going less negative. This causes the base of Q4 and, therefore, the emitter of Q3 and Q4 to become less negative. The process continues until both Q3 and Q4 are saturated. C2 will then discharge through R9 and the base of Q3 to ground. Base current to hold Q3 in conduction is supplied through R7, R8, and R9.

2.48 At 25 degrees C with 390 ohm output load, the delay of the motor delay timer is from 0.475 second to 0.675 second when the supply voltages are within 3 percent of their nominal values.

## POLAR ADAPTER

### A. General

2.49 The following description is based upon schematic wiring diagram 5923WD.

2.50 The polar adapter converts the types of signals received from the receiving leg and the teletypewriter into those usable by the circuitry and the sending leg. Some of the functions of the relay contacts are modified by the polar adapter, but they serve the same general purpose. The outward operations of the call control unit, with the polar adapter attached, are identical to those of the call control unit alone.

2.51 The polar adapter consists electrically of four basic parts. These parts are:

- (a) Receiving polar relay: This relay converts the received signals into those usable by the circuitry of the adapter and the call control unit.
- (b) Sending polar relay: This relay converts the make-break signals generated by the distributor into transmitted line signals.
- (c) Connect control timer: This circuit is made up of four basic parts and differentiates between control and information signals.
- (d) Current amplifier: This circuit amplifies the signals of the receiving polar relay to control the selector magnet driver.

2.52 The polar adapter operates on a 3-wire basis. Two of these wires are the sending and receiving legs. The third wire is an earth return for these two legs. The polar adapter will, therefore, not operate unless earth ground is supplied. The chassis of the polar adapter is grounded to the power supply. When installed in the call control unit, electrical connection is made through the chassis contact to the third wire in the power plug. This third wire in the power cord must be connected to a suitable earth ground.

2.53 The sending and receiving polar relays are of the non bridging mercury-wetted contact type. They are housed in metal cylinders with an 11-pin tube socket at their base. Because of the mercury in the relay capsule, they must be operated within 30 degrees of vertical to prevent shorting of the contacts.

- (a) The coils of the polar relay are as follows:

- Pins no. 2 and 11 - Drive coil
- Pins no. 3 and 10 - Drive coil
- Pins no. 5 and 9 - Bias coil
- Pins no. 6 and 8 - Bias coil
- Pins no. 1 and 7 - Contacts
- Pin no. 4 - Tongue

- (b) In the polar adapter, contact no. 7 has been chosen as the spacing contact and contact no. 1 as the marking contact. To close contact no. 1 and the tongue, current must flow from either pins no. 2 to 11, 3 to 10, 9 to 5, or 8 to 6.

2.54 All polar relay contacts are protected by arc suppressors. These arc suppressors slow the rate of change of voltage across the mercury wetted contacts of the polar relays. On the receiving polar relay the arc suppressors are made up of R32, R33, C5, and C6. On the sending polar relay they are made up of R43, R44, C7, and C8.

2.55 All voltage sources are isolated by at least 120 ohms. In the event of a momentary short, current through the polar relay contacts or the connectors is limited to 1 ampere or less. If a short is of long duration, the resistor will act like a fuse and open the shorted circuit. These resistors are R34, R36, R38, R41, and R42.

2.56 When polar signals are being transmitted by the sending polar relay, a noise suppressor is used in the sending leg. This suppressor consists of a "pi" filter and is made up of C11A, C11B, and R45. The filter rejects all high frequency components of the transmitted signal. It is not used when neutral signals are transmitted.

### B. Receiving Polar Relay

2.57 This polar relay and its associated components convert incoming signals into those usable by the circuitry of the polar adapter and the call control unit.

2.58 Several types of input signals to this polar relay are possible. These modes of operation may be selected by appropriate strapping of the binding posts on the TP181607 printed card assembly. The various modes of operation are:

- (a) Polar signals, battery supplied remotely. This is the normal mode of operation, and all polar adapters are supplied with strapping for this type of operation.
- (b) Neutral signals, battery supplied by the polar adapter. In this condition, posts no. 3 and 4, 5 and 7 and 12 and 13 are strapped together.
- (c) Neutral signals, battery supplied remotely (battery negative). In this condition, posts no. 5 and 12, 6 and 13, and 3 and 4 are strapped together.
- (d) Neutral signals, battery supplied remotely (battery positive). In this condition, posts no. 3 and 4, 12 and 13, and 5 and 6 are strapped together.

2.59 With the wiring as described above, a spacing signal will cause the tongue (4) of the polar relay to rest on the space contact (7). With a marking signal, the tongue will rest on the mark contact (1). The tongue (4) of the polar relay is supplied with +120 volts through R34. It supplies this voltage to the selected contact, while the other contact has no potential applied. Both contacts have two outputs. One of these is a voltage or direct output, while the other is current output. The current output is through a diode and a resistor and will supply approximately 0.010 ampere to ground. The diode prevents reversed currents from flowing when the contact is not supplied with +120 volts from the tongue. The output diodes and resistors are CR11, CR12, R30 and R31.

2.60 The bias for this relay, when used in neutral operation, is 0.030 ampere and is supplied through R37 and strapped terminals no. 3 and 4. Operating current for neutral operation, when supplied locally, is supplied from -120 volts and is limited to 0.060 ampere by R46 and the signal line resistance.

#### C. Sending Polar Relay

2.61 This polar relay converts the neutral make-break signal generated by the dis-

tributor and the dial into those required on the sending leg. There are a variety of possible signal types that can be transmitted. These are:

- (a) Polar signals, battery supplied by the polar adapter. This is the normal mode of operation and all polar adapters are supplied with strapping for this type of operation.
- (b) Neutral signals, battery supplied by the polar adapter. In this condition, posts no. 10 and 11 are strapped together, and the straps between posts no. 8 and 9, 14 and 15, and 16 and 17 are cut.
- (c) Neutral signals, battery supplied remotely. In this condition posts no. 6 and 10 are strapped together, and straps between posts no. 8 and 9, 10 and 11, 14 and 15, and 16 and 17 are cut.

2.62 Since both the drive and bias windings are wired in series, both windings are supplied with the same amount of current. The input current of 0.021 ampere to the drive windings is supplied through R40 from +120 volts. The 0.021 ampere to the bias is supplied through R39 from +120 volts.

#### D. Connect Control Timer

2.63 This circuit consists of four basic parts on the TP181606 assembly. These are: a strobe pulse generator two timing transmission gates, and binary.

2.64 The strobe pulse generator generates a 120 cps square wave. This square wave and the outputs from the receiving polar relay are used as inputs to the two timing transmission gates. The outputs of these two gates are used to control the binary. The output of the binary, in turn, is used to control the connect circuit in the call control unit.

2.65 The strobe pulse generator is made up of Q1 and Q2 and associated components. It is controlled and caused to oscillate by alternating current from the power transformer of the call control unit. This 12.5-volts ac (18-volt peak) sine wave is rectified by CR1 and CR2 to form a negative 120 cps wave. The base of Q1 is biased by R2 and R3 such that -3.9 volts is necessary at the junction of CR1 and CR2 to turn on Q1. When base current does flow to Q1, it will turn on, and its collector will become nearly ground. R4 and R5 form a voltage divider which back-biases the base of Q2

and holds it off. The voltage at the collector of Q2 will be set by a voltage divider made up of R8 and R9. This voltage is -9.1 volts. Feedback, through R6 from the collector of Q2 to the base of Q1, will help provide snap-action.

2.66 When the 120 cps wave becomes more positive than -3.9 volts, base current to Q1 will cease to flow. The collector of Q1 will become -5.7 volts. Base current to Q2 will flow through R5 and cause it to turn on. Its collector will become very nearly ground. This circuit will continue to oscillate as described as long as power is applied to the control unit transformer.

2.67 Two 1-percent tolerance resistors (R8 and R9) in the collector of Q2 set the voltage at that point at -9.1 volts. This voltage level is important in controlling the binary and setting the proper time delay intervals in the timing gates. The square wave generated at the collector of Q2 will be ground for approximately 0.0013 second and -9.1 volts for approximately 0.007 second.

2.68 When spacing signal is present on the receiving leg, +120 volts is applied to contact no. 7 and no voltage is applied to contact no. 1 of the receiving polar relay. No voltage will appear across R28, and the voltage at the junction of R28 and R26 is set by current flow through CR10 and R26. This voltage will be approximately -60 volts. CR8 will conduct and the voltage across C3 and at the anode of CR5 will be held at -60 volts. If Q4 is in conduction, its base will be nearly ground, and CR5 will be back-biased by 60 volts.

2.69 The 9.1 volt strobe pulse introduced at C1 will cause the voltage at the anode of CR5 to rise to -50.9 volts. The negative pulse, that follows in 0.0013 second will lower it to -60 volts. The net result of these strobe pulses upon the voltage on C3 is, therefore, zero, and CR5 is not forward-biased at this time.

2.70 When a marking signal appears on the receiving leg, +120 volts is applied to one side of R28 through the marking contact of the receiving polar relay. The voltage divider consisting of R26 and R28 sets the voltage at their junction at +22 volts and back-biases CR8. This isolates C3 from R26 and R28. C3 will begin to discharge through R20 from -60 volts toward ground. The voltage at the anode of CR5 will follow, thus reducing the back-bias on CR5. After approximately 0.08 second the voltage on

C3, and, therefore, at the anode of CR5, will have risen to -9.1 volts. The next strobe pulse to appear at C1 will cause CR5 to become slightly forward-biased, and part of the pulse will appear at the base of Q4.

2.71 The gate just described is the connect timing gate and produces a signal delay of approximately 0.08 second. The disconnect timing gate operates in a similar manner. The input to R27 is from the spacing contact. When mark appears on the receiving leg, R25 and CR9 hold the voltage on C4 at -60 volts. When a spacing signal appears, CR7 will be back-biased, and C4 will discharge through R19 from -60 volts toward ground. In approximately 1.3 seconds the voltage across C4, and, therefore, at the anode of CR4, will become more positive than -9.1 volts. The next strobe pulse introduced across C2 will cause CR4 to be forward biased, and part of the strobe pulse will appear at the base of Q3.

2.72 C3 will recharge to -60 volts from -9.1 volts in 0.004 second. C4 will recharge in 0.01 second. Both of these recharge times are less than one code element length and can be considered instantaneous.

2.73 The outputs of the transmission gates control the binary which is made up of Q3 and Q4 and associated components. The operation of this binary is similar to that of the binaries in the call control unit. The control of the binary by the transmission gates is the same as that of the 2.3-second timer controlling the local circuit in the call control unit. A positive pulse at the base of Q4, through CR5, will turn off Q4 and turn on Q3. The collector of Q3 will then be near ground. Current will flow through R35 and through ZD1 to the collector of Q3. The cathode of ZD1 will be +9.1 volts with respect to its anode, so that the voltage at the cathode will be +9.1 volts. This point is the output to the connect circuit of the call control unit.

2.74 A positive pulse at the base of Q3 through CR4 will turn off Q3 and turn on Q4. The collector of Q3 will go negative. Current flow through CR6 and R23 will hold this voltage to -18 volts. Current flow through R35 and ZD1 will hold the voltage at the cathode of ZD1 to +9.1 volts of -18 volts. The output will then be -8.9 volts. A negative output (Q3 off) will hold the connect circuit of the call control unit off, and a positive output (Q3 on) will hold the connect circuit on.

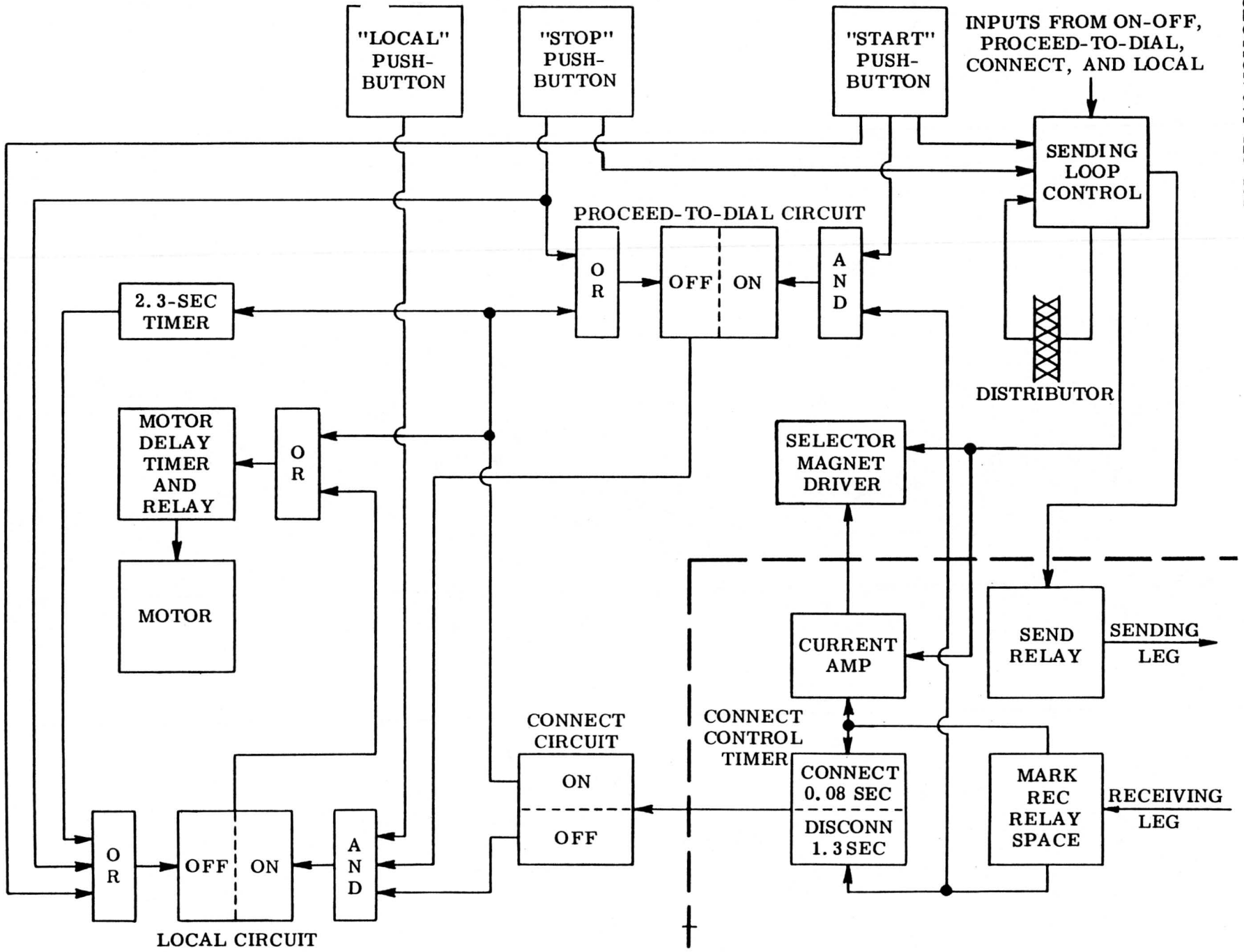

Figure 10 - Block Diagram—Polar Adapter Circuit

## E. Current Amplifier

2.75 This circuit is made up of Q5 and associated components on the 181606 assembly. Base current to this amplifier is supplied through CR12 and R31 from the marking contact of the receiving polar relay.

2.76 If ground is applied to the emitter of Q5 through CR3 or by strapping binding posts no. 1 and 2, the base is back-biased by the voltage divider made up of R13 and R14. If base current is now supplied, the transistor will turn on. With the collector load as shown in Figure 12, 0.060 ampere of collector current will flow.

2.77 If the ground to the emitter of Q5 through CR3 is switched to +120 volts, CR3 will become back-biased. The emitter is biased to near +18 volts through R12. Since both the emitter and collector are biased to +18 volts, no current will flow between them. Base current supplied to the transistor will flow into both the collector and emitter. The current in the collector will flow from the base, through the collector, the selector magnet driver, and R23 to +18 volts. This current flow is in the reverse direction of the normal control current for the selector magnet drive, and it will be held spacing.

2.78 The amplifier will supply marking current only when ground is applied to the emitter, and base current is supplied. If either of these conditions is not fulfilled, the selector magnet driver will not be supplied input current, and its output will be spacing.

2.79 Strapping post no. 1 and 2 will permanently apply ground to the emitter and allow duplex operation of the teletypewriter.

## F. Circuit Interconnections

2.80 Figure 10 is a block diagram showing the polar adapter connected to the call control unit. The call control unit portion of the block diagram is the same as that shown in Figure 5 with one exception. The line sensing and control block of the call control unit is rewired through the connectors (J4, J5, and J6) and is now called the sending loop control. All of the components are identical in these two blocks, but rewiring allows the block to control the sending leg rather than the signal loop. This block also has outputs to the current amplifier and the selector magnet driver. The input to the current amplifier allows the teletypewriter to read its own copy. The input directly to the

selector magnet driver is for teletypewriter blinding.

2.81 The receiving polar relay marking contact supplies inputs to both the connect control timer and the current amplifier. The input to the current amplifier allows the teletypewriter to read incoming copy. The input to the connect control timer allows the polar adapter to recognize a connect signal. The spacing contact supplies inputs to both the connect control timer and the proceed-to-dial circuit of the call control unit. The input to the connect control timer allows the polar adapter to recognize a disconnect signal. The input to the proceed-to-dial circuit supplies current for spacing signals and no current for mark. This allows this circuit to operate in the normal manner.

## G. Idle Line Condition

2.82 In this condition both the sending and receiving legs are spacing. All the circuits in the call control unit are off. The spacing contact of the receiving polar relay is +120 volts and allows C4 to be discharged. CR4 will then allow strobe pulses to pass to the base of Q3 and hold it off. The output of the connect control timer is then negative and holds the connect circuit in the call control unit off.

2.83 Figure 11 is a schematic wiring diagram of the sending loop control circuit with the current amplifier and the sending polar relay. Blinding current to the selector magnet driver flows from +18 volts through R23, J5-2, the selector magnet driver, J4-3, and "hl" contact, the "wl" contact, J4-9, and the distributor to ground. No current flows in the drive coils of the sending polar relay, since neither the start contact, the "a" contact, nor the "hl" contact are operated to supply ground.

2.84 The marking contact of the receiving polar relay has no voltage applied. No base current will then flow from this contact to Q5. The emitter of Q5 is biased to +18 volts through R12. The cathode of CR3 is at +120 volts which is supplied through R39 and the sending relay coils, and CR3 is back-biased.

## H. Initiating a Call

2.85 A call may be initiated when the call control unit is in either the idle line or local conditions as described earlier. Depressing the START pushbutton will allow current

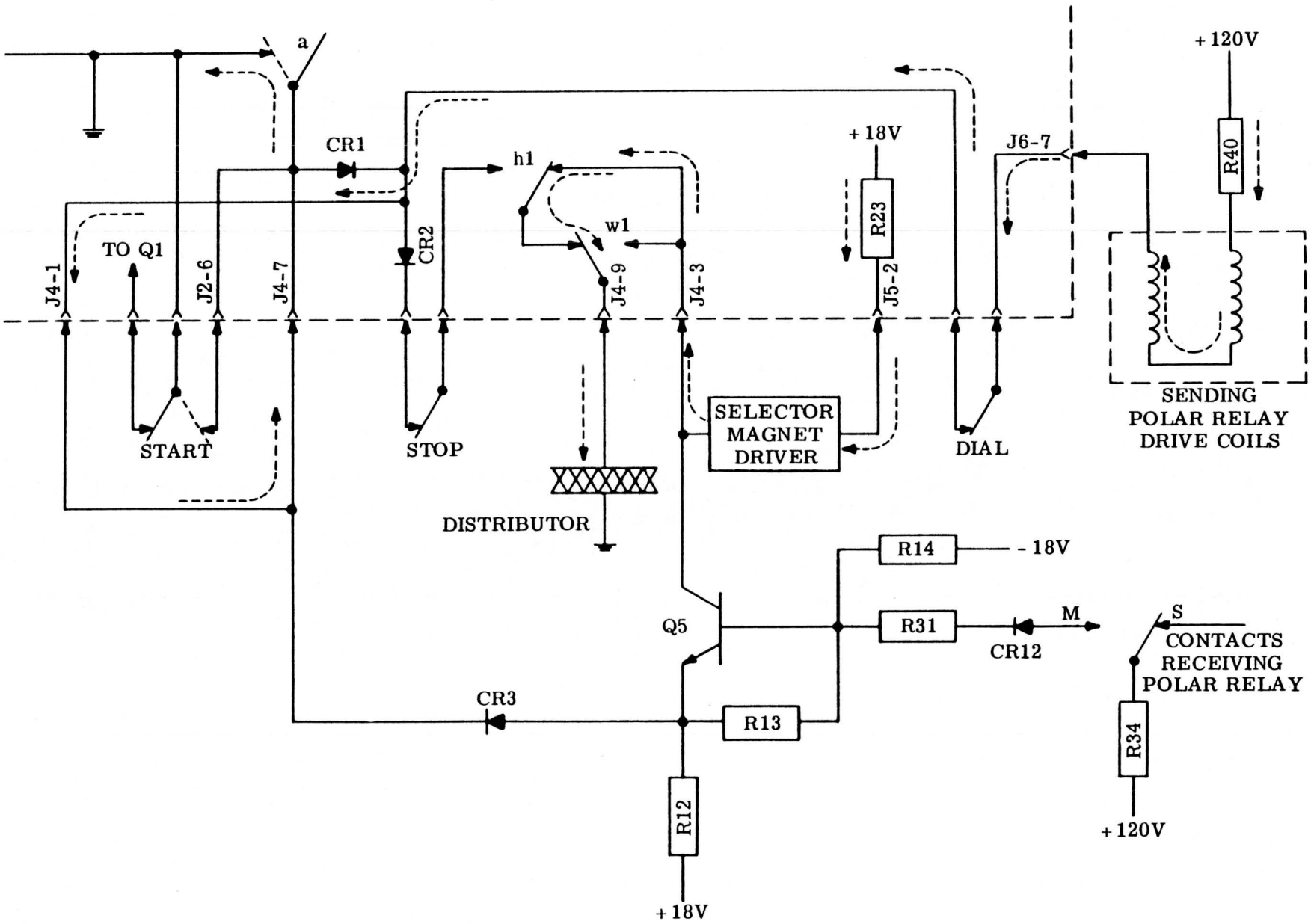
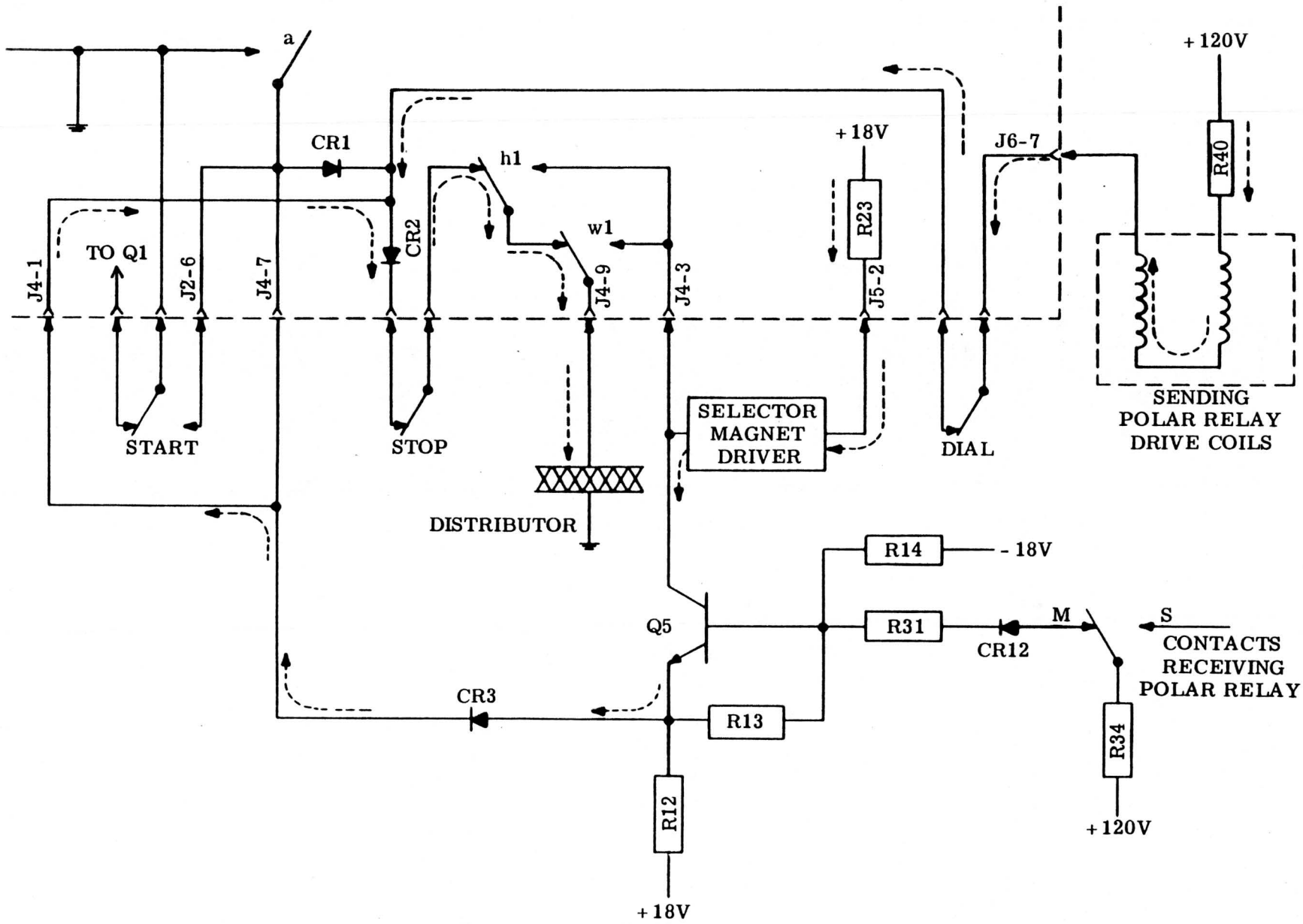

Figure 11 - Sending Loop Control Circuit with Sending Polar Relay

Figure 12 - Receiving Loop Control Circuit with Receiving Polar Relay



to flow through the drive coils of the sending polar relay. This sending polar relay will then transmit a marking signal on the sending leg. The current path through the coils is shown dotted in Figure 11.

2.86 Operating the START pushbutton will also remove ground from the collector of Q1 in the call control unit. Current to the input of the proceed-to-dial circuit (base of Q1) is supplied from the spacing contact of the receiving polar relay. This is not shown in Figure 11. The proceed-to-dial circuit will not operate until this current is interrupted.

#### I. Proceed-to-Dial

2.87 The exchange will recognize the marking signal transmitted as a request to dial. When the exchange has selected the proper equipment, it will transmit a 0.025 second marking signal on the receiving leg. The receiving polar relay will respond to this signal by interrupting the current flow to the input of the proceed-to-dial circuit. This circuit will then turn on, and energize the A(K1) relay and the proceed-to-dial lamp. The "a" contact will operate and shunt out the START pushbutton contact. The START pushbutton may now be released.

2.88 When the receiving polar relay responds to the 0.025 second pulse, C3 in the connect control timer will start to discharge. After 0.025 second the receiving leg returns to spacing and causes C3 to be recharged to -60 volts. In the 0.025 second interval, the voltage across C3 will not rise to -9.1 volts, and no strobe pulses will be passed by CR5. The connect control timer, therefore, will not respond to a proceed-to-dial pulse.

#### J. Dialing

2.89 The dial signaling contacts are in series with the drive coils of the sending polar relay as shown in Figure 11. The dial contacts will thus energize and de-energize this relay whenever current is flowing through them. The make-break signal generated by the dial contacts will be transmitted as mark-space signals by the sending polar relay. These mark-space signals are used by the exchange to make the necessary connection.

#### K. Call Connection

2.90 With the call control unit in the proceed-to-dial condition, the sending leg is mark-

ing, and the receiving leg is spacing. When dialing is completed, the exchange will switch the receiving leg to marking. This signal causes the tongue of the receiving polar relay to transfer and apply +120 volts to R28. CR8 will become back-biased, and C3 will begin to discharge toward ground. After 0.080 second, the voltage across C3 will be approximately -9.1 volts. The next strobe pulse to appear will pass through CR5 to the base of Q4. The output of the connect control timer will then become positive and cause the connect circuit to turn on. As described earlier, the proceed-to-dial circuit will turn off. As the connect circuit turns on, the H(K2) relay will operate, the "h1" contacts will transfer, the CONN lamp will light, and the motor will turn on.

2.91 Current flow to the drive coils of the sending polar relay is now through R40, the drive coils, the dial contacts, CR2, the stop contacts, "h1," "w1," and the keyboard contacts to ground as shown in Figure 12. Base current to Q5 is now supplied from the marking contact of the receiving polar relay through CR12 and R31. Input current to the selector magnet driver will flow from +18 volts through R23, the selector magnet driver, Q5, CR3, J4-1, CR2, the stop contacts, "h1," "w1," and the distributor contacts to ground.

2.92 Both the current paths for the drive coils of the sending polar relay and the selector magnet driver are through the distributor contacts. If the distributor is operated, the signal will be transmitted on the sending leg and cause the selector magnet of the teletypewriter to operate. When information is received from the distant station, the receiving polar relay will operate and make and break base current to Q5. This will cause Q5 to make and break current flow to the selector magnet driver without affecting the sending circuit.

2.93 The longest possible normal spacing signal generated by the distant teletypewriter will be less than 1.3 seconds. This is the length of spacing signal required to cause the connect control timer to disconnect. Therefore, under normal signaling, the connect control timer will not be affected by information signals.

#### L. Remote Connection

2.94 The call control unit may be connected remotely from either the idle line or local condition. An incoming call is indicated by the exchange by its transmission of a marking

signal on the receiving leg. The connect control timer after 0.080 second, will turn on the connect circuit in the control unit. When the "hl" contacts transfer, a current path to ground is set up through the drive coils of the sending polar relay. It will then transmit a marking signal on the sending leg to signify that the unit has connected. The remainder of the operations are the same as described in 2.90 through 2.93.

2.95 If the paper in the teletypewriter has become low and the low-paper contacts operate, the voltage across C3 will be held at -60 volts through R29. This will stop any connections from occurring. If the call control unit is already in the connect condition, when the low-paper contacts close the call may be completed, but subsequent connections will be blocked.

2.96 If a call is originated locally with a low-paper condition, the normal sequence of events will occur until the connection is attempted. When the exchange does not receive a marking signal on the sending leg, it will return the receiving leg to spacing (idle line condition).

#### M. Call Disconnect

2.97 If the STOP pushbutton is depressed while the teletypewriter is in the connect condition, the stop contacts in series with the drive coils of the sending polar relay will open. The relay output will then be spacing. The exchange will recognize this long spacing signal as a request to disconnect and will send a spacing signal on the receiving leg. The receiving polar relay contacts will transfer and allow C4 to discharge toward ground. After 1.3 second, the voltage across C4 will be -9.1 volts, and the next strobe pulse will pass through CR4 to the base of Q3. The output of the timer will become negative and turn off the connect circuit in the call control unit. When the "hl" contacts transfer, current to the drive coil of the sending polar relay will be held off so that the STOP pushbutton may be released. The "hl" contacts will now also supply blinding current to the selector magnet driver. The control unit is now in the idle line condition.

#### N. Remote Disconnect

2.98 When the remote unit generates the spacing signal to disconnect, the receiving polar relay will allow C4 to discharge and after 1.3 seconds the timer will turn off the connect circuit. The "hl" contacts will trans-

fer, stopping current flow to the drive coils of the sending polar relay and blinding the selector magnet driver. The call control unit is now in the idle line condition.

#### O. Local Off-Line Operation

2.99 This operation is identical to that of the call control unit without polar adapter except for the current path to the selector magnet driver. This path is shown in Figure 11.

### 3. CALL CONTROL UNIT—BELL SYSTEM SWITCHED NETWORK SERVICE

#### OPERATION

##### A. General

3.01 The call control unit provides for signaling speeds of 100 wpm from dc marking and spacing intelligence pulses originating from the distributor in the associated teletypewriter. These pulses are directed to the input of the selector magnet driver in the call control unit where they are amplified and returned to the typing unit as 0.500-ampere dc pulses to operate the selector magnet.

3.02 If the originate (ORIG) pushbutton (non-locking) on the call control unit has been depressed and connection with a called station has been satisfactorily completed, the intelligence pulses originated by the distributor are sent to the data set. The data set converts the dc pulses to tone signals for transmission over telephone lines. Another data set, located at the called station, converts the tone signals back to dc pulses, which are directed to the input of the selector magnet driver to operate the selector in the teletypewriter of the called station. The teletypewriter at a given station copies both the transmitted and received dc signals, operating on a half-duplex basis.

3.03 Although the data set is not a part of this equipment, a brief discussion of its function is necessary to understand the operation of the system. Start-stop dc signal pulses form essentially a square wave which cannot readily be transmitted over telephone lines. The data set is basically a converter which changes the dc signals from the sending or calling station into frequency-shifted tones for transmission over the telephone network. A marking pulse from a sending station is converted to a 1270-cycle marking signal (F<sub>1</sub> mark) and a spacing pulse becomes a 1070-cycle spacing signal (F<sub>1</sub> space).

The data set at the receiving or called station sends a 2225-cycle marking signal ( $F_2$  mark) and a 2025-cycle spacing signal ( $F_2$  space). During transmission of a message the calling station sends mark and space tones ( $F_1$  mark and space) while the called station sends a continuous mark tone ( $F_2$  mark). In this way the telephone facilities are operated on a full-duplex basis. If the signal received at either station ( $F_1$  mark and space at the called station and  $F_2$  mark at the calling station) shifts to a space tone for more than one second, or if the received signal is lost for one second, the data set will cause the station to be disconnected. This provides assurance that the connection is maintained for the entire period of message transmission.

3.04 The call control unit used with the data set operates with conventional telephone central offices that have the necessary routing and accounting facilities. In operation, a call is originated by depressing the ORIG pushbutton. A lamp illuminates the pushbutton and the dial tone will be heard through a loudspeaker. If the line is busy, a busy signal will be heard and the clear (CLR) pushbutton (non-locking) should be depressed. If the line is not busy, the operator dials the number of the desired station. This causes the called station to go into connect condition. If the teletypewriter is manually operated, the called station operator presses the answer (ANS) pushbutton (non-locking). Following a short interval, about 1-1/2 seconds, in which telephone facilities are connected, the called station transmits a mark tone ( $F_2$ ) and receives a mark tone ( $F_1$ ) from the calling station. Receiving the continuous  $F_2$  mark tone from the called station for second causes the calling station to go into connect condition, and its motor is turned on. Likewise, the continuous  $F_1$  mark tone from the calling station for 1 second causes the called station to go into connect condition, and its motor is turned on. Either station can now transmit.

3.05 At the end of the message, either station may originate a disconnect by depressing the CLR pushbutton, at which time each station goes back to its idle condition, ready to receive or originate other calls. For keyboard practice, maintenance purposes, or preparation of copy, the local mode (LCL) pushbutton (locking) is depressed. This turns on the motor and disables automatic answering facilities, if present. In the event of an incoming call during local operation, the call control unit responds to ringing signals and the ANS push-

button must be operated manually. Operation of the test (TST) pushbutton (locking) causes received signals to be retransmitted to the test center for maintenance purposes. A lamp, associated with each pushbutton, illuminates the pushbutton whenever that pushbutton has been operated and the operating condition exists. The ANS lamp is pulsed in response to ringing signals of an incoming call, and lights continuously when the call is answered. The CLR lamp is automatically extinguished 1.5 seconds after the pushbutton has been depressed, and disconnect is completed.

3.06 A steady mark signal blinds the associated teletypewriter during all intervals, except when in the connect condition. This prevents spurious characters from being printed except when due to loss of signals, circuit noise, or deliberate break or space-disconnect signals.

#### B. Power Requirements

3.07 Power input to the teletypewriter is 115V  $\pm$ 10 per cent, 60 cps  $\pm$ 2 percent. Average power consumption is 35 watts (not including typing unit motor) with peaks up to 50 watts permitted.

#### PROGRESS OF A CALL

3.08 To originate a call, the ORIG pushbutton is momentarily depressed. This connects the station to the line and lights the ORIG lamp. During the period of time in which connection is being made, the telephone central office makes no time measurements. When the ORIG pushbutton is closed, the call control unit is connected to the telephone line through the data set and an off-hook condition is set up. The amplifier is connected into the circuit so that the dial tone from the central office is heard. The called station is dialed while the amplifier monitors the progress.

3.09 At the called station audible and visible signaling devices are operated. The called station goes off hook and into the connect condition upon operation of the ANS pushbutton circuit, by manual or automatic means, at the distant point. At this time, there is a nonsignaling interval of 1.225 seconds during which accounting and toll recording facilities at the telephone exchange will be cleared. Following the nonsignaling interval, the called station transmits its  $F_2$  mark tone and sets its monitoring timer to respond to the  $F_1$  mark tone

from the calling station. When the continuous  $F_2$  mark tone is received at the calling station for a period of 1 second, indicating that a station has answered, it will go into the connect condition and turn on its motor. When the continuous  $F_1$  mark tone is received at the called station for an interval of 1 second, it will go into the connect condition. The station may now acknowledge the call either by operator keyboarding, or by automatic answer-back message transmission. The monitoring timers at both stations are set to respond to reception of a space tone from the distant station. Traffic can now be exchanged from either station on a half-duplex basis.

#### DISCONNECTING A CALL

3.10 During the time the two stations are connected (traffic interval), either station can initiate a disconnect as follows:

(a) A call is normally terminated by the end-of-transmission (EOT) code combination which provides fast disconnect without introducing hit characters. This is accomplished by the data set in response to EOT contact closures in function boxes of both the sending and receiving teletypewriters.

(b) A call connection can also be cleared manually by momentarily depressing the CLR pushbutton. Operation of the CLR pushbutton at either station will cause transmission of a spacing signal of 1.5 seconds duration, after which the station originating the disconnect will discontinue its tone transmission and go back on hook. The other station, after receiving the spacing signal for 1 second, will automatically transmit its 1.5-second spacing signal and then go on hook. Both stations will then be back in their original idle condition in which calls can be either originated or accepted.

#### ANSWERING A CALL

##### A. Manual Answering

3.11 To answer a call manually, momentarily depress the ANS pushbutton. This connects the station to the line and lights the ANS lamp. The lamp remains lighted until the answer mode is terminated. Manual answering is necessary only when the automatic answer-back circuit is disabled. The automatic answer-back circuit is disabled by low-paper contacts,

data set relay contacts (when in local mode), and the OUT OF SERV. key.

##### B. Automatic Answering

3.12 Call control units equipped with automatic answering facilities will respond to received ringing signals, turning the teletypewriter on at the end of the ringing interval and proceeding through to the connect condition. Automatic message answer-back is a part of this feature. The presence of an operator is required in order to complete disconnect and return the teletypewriter to idle condition. For unattended service, an automatic disconnect timing device (optional) actuated when a call is answered, will cause the teletypewriter to go through the connect condition, send the 1.5-second spacing tone, and go back on hook if the  $F_1$  mark tone is not received within 8 seconds after the called station answered. This is designed to prevent the unattended station from being made busy by (telephone) calls that fail to cause a full connection to be set up. This feature does not affect normal automatic disconnect upon receiving the 1-second spacing tone or loss of tones due to a dropoff.

#### LOCAL MODE

3.13 The local mode (LCL) provides off-line operation of the teletypewriter. The operator selects the local mode by depressing the LCL pushbutton. This lights the LCL lamp and operates the motor control relay (MCR) to energize the motor. The data set connects the sending circuit to the receiving circuit and enables the keyboard and answer-back to transmit. In this condition the teletypewriter can be used for preparing copy, for operator practice, or for maintenance purposes. If an incoming signal is received during this time, ringing signals are received and manual operation of the ANS pushbutton is required in order to receive the message. If the teletypewriter is in a terminal hunting group, the operator must turn the out-of-service (OUT-OF-SERV.) knob to the RESTORE position momentarily and then to NORMAL.

#### "OUT-OF-SERV." SWITCH

3.14 The OUT OF SERV. switch prevents the automatic answering of incoming calls. In its NORMAL position (arrow on knob upright), it has no effect or function; in the OUT OF SERV. position (knob rotated counterclockwise and detented) it sets the following conditions:

- (a) A contact is closed that causes the OUT OF SERV. lamp to light.
- (b) A contact is closed that shorts the ringer coils. This makes the ringer inoperative. As an option the contact can be located to shunt both the ringer and series capacitor (i e , the telephone line). This makes the station appear to be in an off-hook condition or busy to the central office.
- (c) A contact is opened that breaks the automatic answer circuit to the answer relay. This prevents the relay from operating in response to the ring-up relay and thus the teletypewriter will not answer.

5 For stations that are not in terminal hunting groups, the operator may return the teletypewriter to service by turning the OUT OF SERV. knob to the NORMAL position. For terminal hunting stations, however, the operator must turn the knob to the RESTORE position and hold it until a dial tone is heard. In this position:

- (a) A contact is closed that shorts the tip to ring (off-hook condition). This condition is detected by the central office which then releases the teletypewriter from lock-out and applies the dial tone.
- (b) A contact is closed that completes a path from the speaker amplifier to ground. This permits the amplifier to pass the line signals (dial tone).

OUT OF SERV. switch is then restored to NORMAL.

#### LOW-PAPER ALARM

3.16 A low-paper alarm is provided in the teletypewriter. When a low-paper condition occurs, make contacts in the low-paper switch provide ground to the low-paper buzzer, permitting it to operate. Depressing the buzzer-release (BUZ-RLS) pushbutton (locking) in the call control unit silences the buzzer and causes the BUZ-RLS lamp to light. Attempting to release the pushbutton without replenishing the paper supply will result in the buzzer operating. When the paper has been replenished, the teletypewriter is returned to normal by releasing the BUZ-RLS pushbutton.

3.17 Break contacts on the low-paper switch disable the automatic answer-back circuit. The operator can override this condition by answering manually. If the low-paper alarm occurs during a call the operator has the option of completing the call before changing the paper, or interrupting the call. To interrupt the call, the operator stops transmission by depressing the keyboard BREAK key, and then depressing the BRK-RLS pushbutton to notify the distant station of the problem. The connection is cleared by simultaneously operating the control (CTRL) and EOT keys on the keyboard. Turning the OUT OF SERV. knob to the detent position insures that the teletypewriter will not automatically answer a call while paper is being replenished.

3.18 To restore the teletypewriter to service after the paper has been inserted, depress the CLR pushbutton and return the OUT OF SERV. knob to its NORMAL position. (For teletypewriters in terminal hunting groups, turn the knob to its RESTORE position and hold it there. When dial tone is heard, release the knob.) The teletypewriter is now in a normal idle operating position.

#### RESTRAIN LAMP

3.19 This high intensity restrain (REST) lamp lights when a restraining signal is received from an 8-level to a 5-level converter used in transmission to 5-level TWX stations on the DDD switching plan. The lamp remains lighted until the restraining signal is removed. The purpose of this feature is to limit the sending speed from 8-level teletypewriter transmitting at 100 wpm to 5-level teletypewriters receiving at 60 wpm.

#### TEST MODE

3.20 If the TST pushbutton is operated while the teletypewriter is connected to a test center, the message sent by the test center will be recorded on the teletypewriter and turned around and sent back for analysis. This is accomplished by connecting the teletypewriter to the data set through a set of transfer contacts and a break contact to ground. This type of operation can be terminated by momentarily operating any of the nonlocking pushbuttons which will then release the TST locking pushbutton.

## SIGNAL GENERATION

3.31 The teletypewriter can send by operating the keyboard, answer-back mechanism, or BREAK key. The keyboard signal generator contacts and answer-back contacts are in parallel with the signal generator (distributor) which is, in turn, connected to the data set. The BREAK key connects to the data set via separate leads.

## SELECTOR MAGNET DRIVER

## A. General

3.22 The data set supplies a 20-ma dc signal to the selector magnet driver associated with the teletypewriter. The selector magnet driver amplifies the signal to 500 ma to operate the selector on the teletypewriter. The selector magnet driver is a 2-stage transistorized amplifier capable of switching high output currents (0.500 ampere) at very closely controlled input current levels. The output of the selector magnet driver is automatically regulated and is

essentially independent of normal variations in power supply voltage and of selector-magnet and current-limiting resistance values.

## B. Circuit Description

3.23 Figure 13 illustrates a schematic drawing of a selector magnet driver circuit.

3.24 Open Line: When the line circuit is open (spacing), transistor Q1 will be turned on by the regulated current flowing through R1 into its base. This current, which is controlled by R1, will be set near the desired switching level. With Q1 conducting, Q2 will be cut off, since the potential at the base of Q2 will be more positive than at the emitter. In this condition only small leakage currents will flow in the collector circuit.

3.25 Space-to-Mark Transition: As the space-to-mark transition begins, the negative bias current flowing in the base of Q1 is diverted to the line circuit. As the line current rises toward the marking current value, it

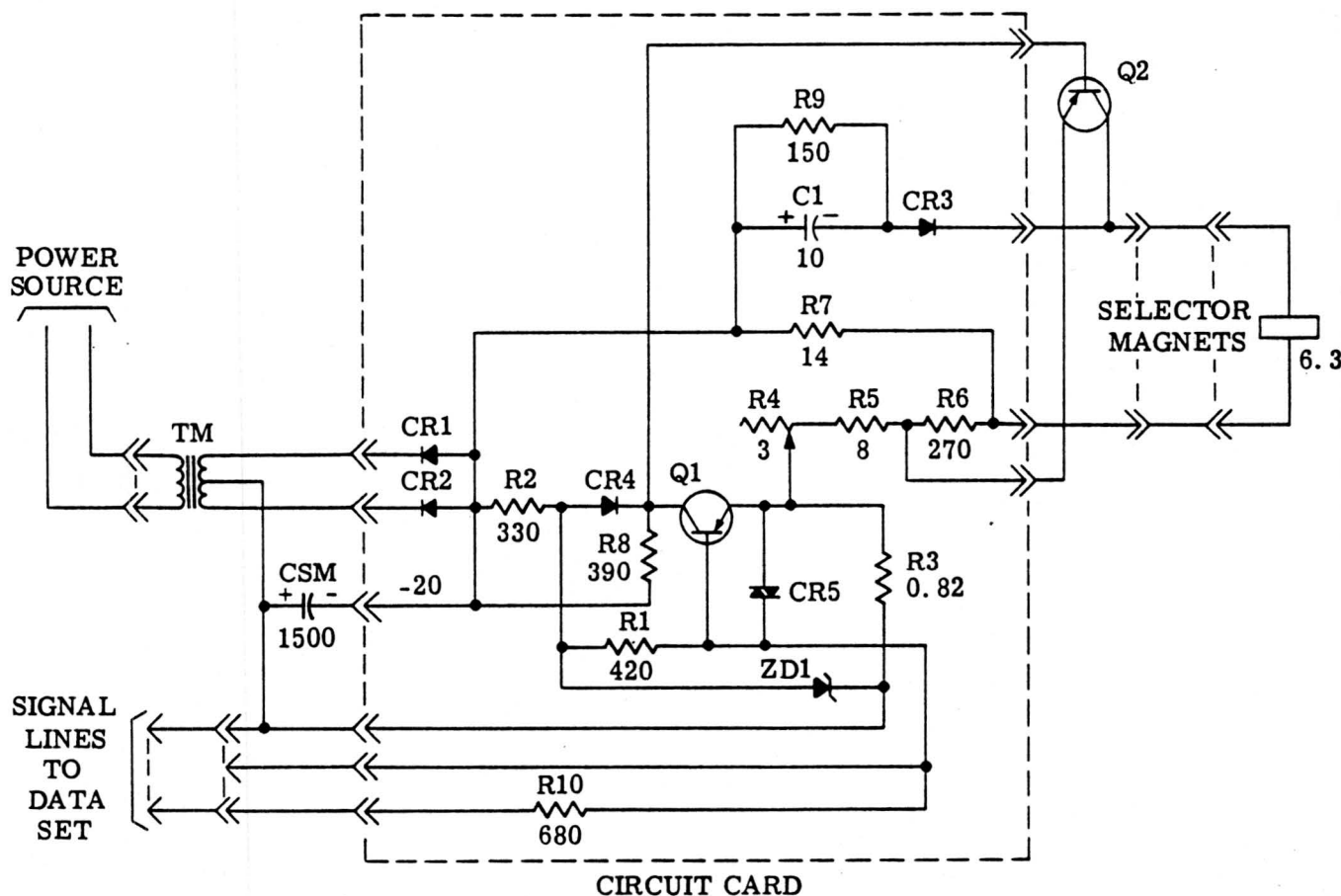

Figure 13 - Selector Magnet Driver Circuit

extracts base current from Q1. When the line current approaches the total current supplied to the base of Q1 to within 0.001 ampere, which is about one-half the nominal mark current value, Q1 begins to turn off. Q2 will then begin to receive forward bias current from R8 and begin to turn on. The base current will then be amplified by Q2, and a current which is a multiple of the base current will appear in the emitter circuit. This increase in emitter current results in an increase in the negative potential measured across R3. The increase in the negative potential at the emitter of Q1 causes it to go further into cutoff. The feedback process continues until the current in the selector magnet reaches a value which is determined by the Zener reference voltage, clamp diode 4, and the emitter resistance of Q2 (the emitter resistance of Q2 is adjusted by R4 to compensate for component variations. As the line current completes the transition to the final marking current value, the base of Q1 becomes positively biased. The positive bias current will be approximately one-half the total marking line current. The positive potential to the base of Q1 is clamped to approximately 0.6 volt by the input protecting varistor, CR5.

3.26 Mark-to-Space Transition: The line current, in changing from mark to space, will finally reach the point where R1 will begin to supply some forward current to the base of Q1. The line current level at which this occurs will be a little more negative than the point at which the circuit switched from space to mark, due to the common emitter resistor voltage drop. As Q1 begins to turn on, the current through R8 will be diverted from the base of Q2, causing it to begin to turn off. As Q2 turns off, the voltage across R4 will begin to go positive, causing Q1 to be further turned on. This effect gives regeneration to the mark-to-space transition.

3.27 Mark-to-Space Switching Transient: When Q2 is turned off during the mark-to-space transition, a negative voltage transient is developed at its collector. This transient is due to dissipation of the energy stored in the magnetic field of the driven magnet when energized by 0.500 ampere. If the high voltage developed at the collector of Q2 were not limited, it would continue to rise until it reaches the point where the collector-to-emitter breakdown voltage is exceeded. It has been found that repeated breakdown of this kind causes deterioration of the transistor and finally a collector-to-

emitter short circuit. Therefore, it is necessary to provide a transient suppressing network at the collector of Q2. The transient-suppression network presently in use is a compromise which affords a minimum peak voltage combined with a magnet release time to provide for adequate teletypewriter margins. The network consists of C1 in parallel with R9. CR3 isolates the network from voltages more positive than negative battery potential.

#### SPEAKER AMPLIFIER SYSTEM

3.28 Figure 14 illustrates a schematic diagram of a speaker amplifier circuit.

3.29 The speaker amplifier is powered only after the ORIG key is operated and is quieted when the station connects. It has two inputs, one from the telephone line via the buffer amplifier in the data set limiter and the other from the multifrequency (MF) tone dialer. Three outputs are provided: (1) into the speaker or optional hand-held receiver; (2) into the telephone line through the sending amplifier in the data set; and (3) an auxiliary output into the data set. The line-to-speaker connection permits monitoring of supervisory signals when originating a call. The TOUCH-TONE dial-to-line and TOUCH-TONE dial-to-speaker connection provides for amplification of the outgoing MF dialing signals and for monitoring them during outpulsing. The line-to-second-output connection is provided for the dial tone detector (when furnished). The various connections mentioned are established by switching in the data set and by the common switch in the TOUCH-TONE dialer.

3.30 The speaker amplifier is a conventional direct-coupled, 2-transistor audio amplifier. The input signals from the telephone line are fed through the receiving buffer amplifier in the data set into the primary winding of the input transformer (T1). The primary winding continually carries approximately 4 ma quiescent current from the receiving buffer amplifier. The other input, from the TOUCH-TONE dialer is fed directly into Q1 through C5. Both inputs are dc isolated from the amplifier stages.

3.31 Two outputs are taken from transistor Q2, one from the collector circuit and the other from the emitter.

- (a) The collector output is fed through a step-down output transformer (T2) into

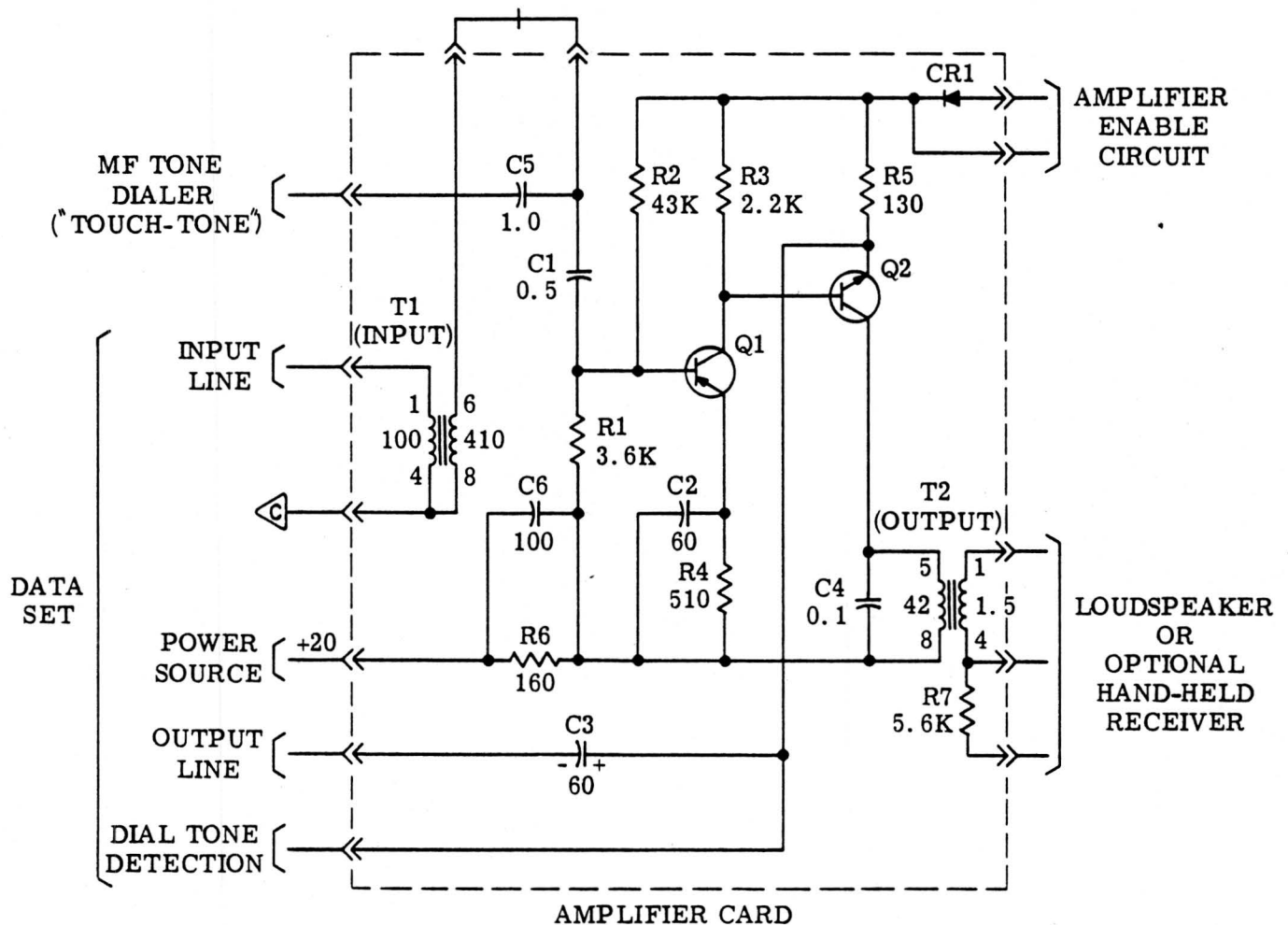

Figure 14 - Speaker Amplifier Circuit

the speaker (or receiver). A potentiometer is used to set proper volume for varying loop loss and ambient noise level. The TOUCH-TONE dialer signals are independent of loop loss.

(b) The emitter output splits into two signal lines: one for injecting the MF dial tones into the data set sending amplifier, and the other for feeding the dial-tone detection circuit (when provided). The signal level from the emitter output is essentially independent from the setting of the potentiometer.

3.32 Bypassed R6 is a supply voltage dropping resistor. Diode CR1 is provided to block a sneak path (in the answer mode) from ground through the ANS and ORIG lamps. Without the CR1, the ORIG lamp would be dimly lit and the amplifier would not be silent when the station is in the answer mode. The amplifier operates only in the originate mode until the station connects. In any mode other than originate, the ground is disconnected. When the

station connects, the amplifier input is short-circuited in the dial set.

## DIALER MECHANISMS

### A. Pulsing Rotary Dialer

3.33 For rotary dialer applications, a pulsing contact of the rotary dialer is inserted into the telephone line. The manual rotary dialer is equipped with a normally closed pulsing contact and a normally opened off-normal contact. The pulsing contact is inserted into the telephone line when the station originates a call. When answering, a short circuit is applied across the pulsing contact. The off-normal contact is placed across the output of the amplifier and silences the speaker whenever the dialing disc is moved.

### B. Pulsing Card Dialer (40A Dialer)

3.34 The 40A dialer is operated by direct current furnished from the central office.

3.35 To use the card dialer, the ORIG push-button is depressed. After a dial tone has been received, a card with the telephone number punched in it is inserted in the slot and entirely pushed in. This operation winds a spring motor, which later pushes the card out of the slot as the dialing proceeds.

3.36 The card dialer is started by momentarily depressing the START bar. This operates the card dialer start contact and establishes a path from the ring side of the telephone line through point no. 5 on the card dialer, the released pulsing relay K(P) contacts, released home and dial start contacts, operated dial start contacts, and point no. 2 on the card dialer to the tip side of the telephone line. The current from the central office battery operates the K(P) contacts which transfers the ring-to-tip path to the matrix. This path is closed or opened according to the code punched in the card. The dial pulse is transmitted as the sensing springs sense the holes in the card.

3.37 Sending of the dial pulse means interruption of the current in the telephone line. This releases the K(P) contact. Movement of the K(P) relay armature rotates the scanning drum by 1/16 revolution so that the next digit pulse can be sensed and transmitted as the K(P) relay reoperates. After two pulses have been transmitted, the home contacts operate and remain operated until the end of the scanning drum revolution. This establishes a direct operating path for the K(P) relay so that, when the station is returned on hook in the middle of the digit, the digit pulsing can be completed and the drum will be returned to its normal (home) position.

3.38 In this manner, the drum completes the revolution in 16 steps. Ten of the steps are required to send the digits, and six to provide the interdigital time. At the completion of the revolutions, an escapement is tripped which permits the next row of holes on the card to be placed in position for sensing.

3.39 This sequence is repeated at each row as the card advances out of the card dialer. If no "stop" code is punched in the card, the card dialer will keep advancing the card (even if no number code is punched) until the card is released. If the "stop" code is sensed, the card dialer stop contacts operate. With the home contacts released, a transmission path is established from the telephone line to the data set input as follows: Ring side of the telephone line

through point no. 5, dial stop contacts operated, home contacts released, point no. 1, hybrid transformer in the data set, to the tip side of the telephone line. The data set can then complete the connection.

3.40 When the station is connected, the card can be released by operating the RELEASE bar. No attempt should be made to release the card by reoperating the START bar, as this will trigger the card dialer mechanism and the following short circuit will be placed across the output of the data set: Point no. 1, home and dial start contacts released, dial start contacts operated, point no. 2. And, after the two first pulses on each revolution: Point no. 1, home contacts operated, point no. 6. This shunt will prevent the station from receiving or sending until the card is disengaged. If this condition persists, the data set will disconnect.

#### C. Pulsing Card Dialer (41A Dialer)

3.41 Figure 15 illustrates a schematic drawing of a pulsing card dialer (41A dialer).

3.42 In locations with 60-cycle ac power the 41A dialer is used. In this dialer the power to operate the commutator disc is derived from a synchronous motor powered by the 14V ac source in the teletypewriter. The power to advance the card in the dialer is derived from a spring wound by inserting the card in the slot. The switching functions and the motor control are independent of the signal path. These features result in a superior performance as compared with the 40A dialer.

3.43 To operate the dialer, the card is inserted and the START bar is momentarily operated. This closes the start contacts and power is applied to the motor which starts driving the commutator disc. In rotating, the disc closes and opens the path between points no. 5 and 6, causing the dial pulses to be sent to the line.

3.44 When the pulses sent reach the number punched in the card, control relay K1 operates. Operation of K1 applies a short circuit between points no. 5 and 6 and disengages the clutch, allowing the disc to return home. Mechanical linkage then permits the spring, wound by inserting the card, to advance the card for the next digit to be read and dialed.

3.45 As the "stop" code is read, the dialing stops. The card can then (as also at any



Figure 16 - TOUCH-TONE Card Dialer Circuit

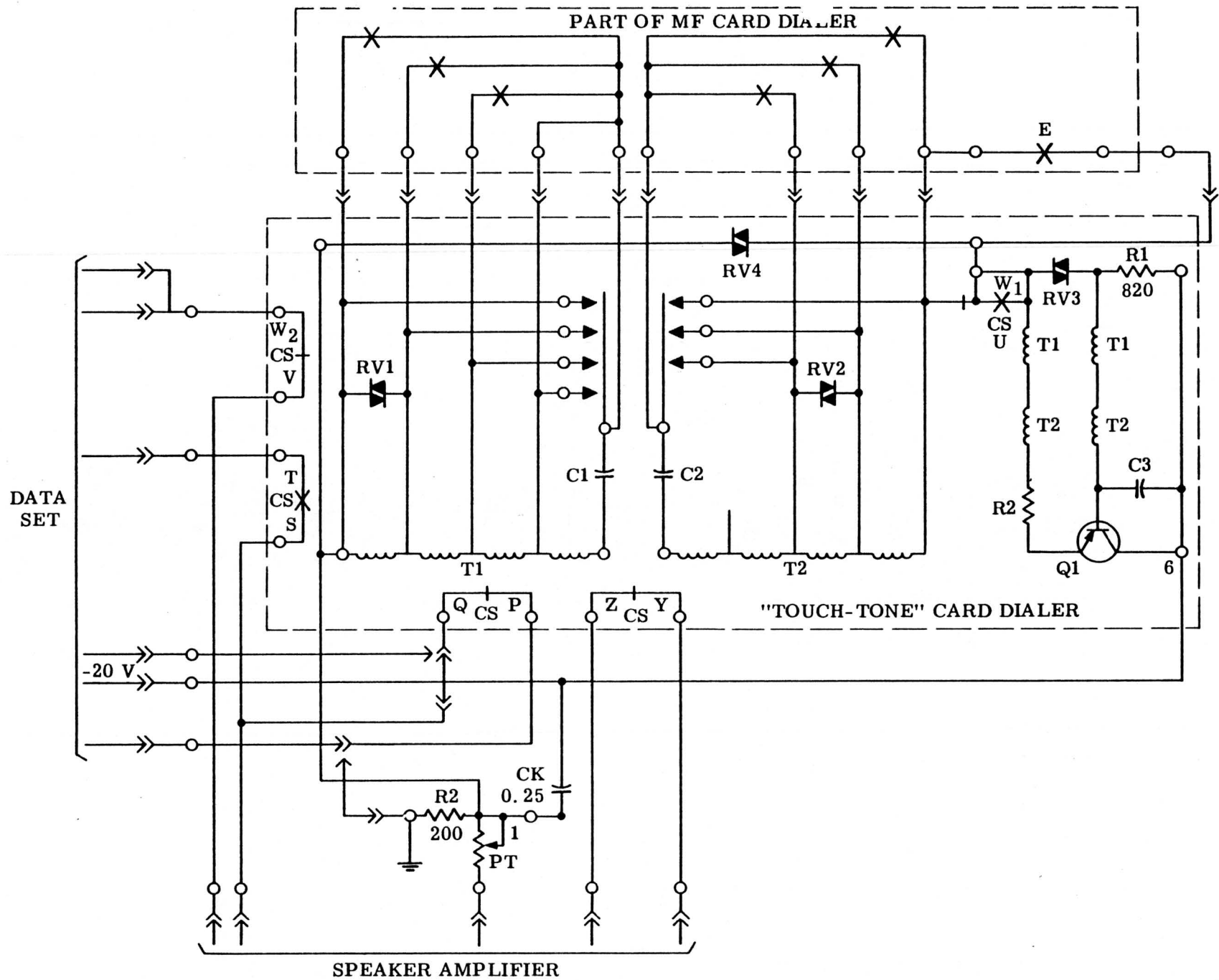

3.49 When the station is idle, a current of about 25 ma flows from ground through PT resistance of point no. 1 of the TOUCH-TONE dialer; then through varistors RV3 and RV4, resistor R1, and out of point no. 6 to -20V in the data set. The transistor Q1 is energized, so that there will be no click when the circuit starts to generate the MF signal. The oscillations are suppressed by dc current through the tank coils T1 and T2 maintained by the potential difference across RV4. By interrupting this initial coil current the oscillation build-up time is minimized.

3.50 To dial a digit, a pushbutton on the dialing plate is operated. This closes two frequency-determining contacts, one for the T1-C1 tank circuit, and the other for the T2-C2 tank circuit. The common switch (CS) operates in the following sequence:

- (1) Y-Z contacts open, making the speaker amplifier input available to MF signal only.
- (2) S-T contacts close and establish a path from the speaker amplifier, through the sending amplifier in the data set, and into the telephone line. The feedback through the receiving buffer amplifier in the data set back into the speaker amplifier is disabled by previously operated Y-Z contacts.
- (3)  $W_2$ -V contacts open, disabling the receiving buffer amplifier in the data set. This eliminates a possibility of false connect due to MF signals.
- (4) Q-P contacts open, together with  $W_2$ -Y contacts, resetting the dial-tone detecting circuits, when furnished.
- (5)  $W_1$ -U contacts open, interrupting the dc current through the tank coils. Since the tank T1-C1 and T2-C2 are coupled to the coils in the Q1 circuit, the unit starts oscillating with a very short build-up time.

3.51 The same functions could be assured with  $W_2$ -V contacts operating first and Y-Z contacts eliminated. However, the interruption of current in the primary coil of the input transformer in the speaker amplifier would cause a loud click to be heard every time a digit is dialed.

3.52 The frequencies above 1000 cps are generated at a somewhat higher level to com-

pensate for greater line loss at those frequencies. There is also a variation of amplitude for various digits. The PT resistor is set at the time of assembly of the call control unit with the data set for an output of 0 dbm on the telephone line for the digit with the highest output level.

#### E. TOUCH-TONE and Card Dialer

3.53 To use the automatic card dialer, the ORIG pushbutton is depressed. After the dial tone has been received, a punched card is inserted into the slot and pushed down. The START bar is then momentarily operated. The card dialer proceeds with dialing under power of a spring motor wound by insertion of the card. When a "stop" code is read, the dialing stops. The card should then be released by re-operating the START bar.

3.54 The sensing contacts in the card dialer are in parallel with the frequency-determining contacts in the associated TOUCH-TONE dialer. As the card advances out of the slot, the sensing contacts sense the holes punched in the card and thus determine the proper frequencies to be transmitted. This occurs for every row on the card.

3.55 The normally opened E contacts in the card dialer are placed across the excitation  $W_1$ -U contacts in the TOUCH-TONE dialer. When dialing manually, the E contacts are opened and there is no interference from the card dialer. With the card down in the slot, the operation of the START bar closes the E contacts and operates the common switch, through mechanical linkage, for the duration of dialing. The common switch connects the input and output circuits of the loudspeaker amplifier, as described previously. Opening of the  $W_1$ -U contacts transfers the excitation function to the E contacts in the card dialer. As the card advances out of the slot, the E contacts open for each row, exciting the TOUCH-TONE dialer into generating the MF signals.

3.56 During dialing, there are short intervals of time when all the sensing contacts are opened and the E contacts are open. Therefore, the TOUCH-TONE dialer will break into spurious oscillations somewhere between 7 and 14 kc. Although this frequency band is suppressed by the telephone line, these frequencies would be noticeable on the loudspeaker. The actions of capacitors CK and C4A in the

speaker amplifier combine to suppress this spurious signal from reaching the loudspeaker.

3.57 Since the card advances out of the slot very rapidly, there is no need for a separate RELEASE bar. When the station connects, relay contacts in the data set disconnect the MF signal input and remove any hazard connected with false operation of the TOUCH-TONE dialer.

#### 4. CALL CONTROL UNIT—PRIVATE WIRE SERVICE

##### OPERATION

4.01 Power for the motor, selector magnet driver, local power supply, and tape reader power pack, when provided, is supplied from fused 115-volt ac, 60 cps power. Direct current of either 0.020 or 0.060 ampere is required for the signal line(s) and for operation in the local mode. Battery for the signal line(s) is supplied by the customer's facilities, while local battery for operation in the local mode is furnished through the operation of the local power supply circuit in the call control unit. At the rear of the call control unit is a terminal strip which provides the point of entry for the ac power and the signal line(s) into the teletypewriter.

4.02 The purpose of the selector magnet driver is to amplify received dc marking and spacing intelligence pulses. Received dc intelligence pulses are directed to the input of the selector magnet driver circuit in the call control unit where they are amplified and returned as 0.500-ampere dc intelligence pulses to operate the typing unit selector. A detailed description of the operation of a selector magnet driver is given in 3.22 through 3.27. The selector magnet driver described there is similar to the ones used in private wire service.

4.03 A 3-position rotary power switch is the only manual control on the call control unit. Its purpose is threefold: Through the operation of the rotary power switch, the teletypewriter can be (1) placed in the external signal line loop for communication with other teletypewriters, (2) removed from the external signal line loop for local operation, or (3) placed in the off condition.

#### POWER SWITCH

4.04 Figure 17 is a schematic drawing of the rotary power switch and local power supply circuits. The following chart indicates the condition of the rotary power switch contacts - either open or closed - when the control knob is turned to one of its positions:

Knob Position	Line Segment		Contacts Condition
	From	To	
LINE	L1	2	Closed
	L1	1	Closed
	L2	2	Open
LOCAL	L1	2	Closed
	L1	1	Open
	L2	2	Closed
OFF	—	—	All Open

4.05 With the rotary power switch in the off mode—the control knob is in the OFF position—the signal line is diverted around the local teletypewriter, and other teletypewriters in the external signal line loop can communicate without interference. All power in the call control unit, except the ac power to the selector magnet driver, is off.

4.06 When the rotary power switch is placed in the local mode—the control knob turned to the LOCAL position—the line relay is not energized. The normally closed contacts A remain closed, and the normally open contacts B remain open. In this condition the circuit is such that (1) local battery is supplied to the selector magnet driver and the send circuit, (2) the external signal line loop is divorced from the selector magnet driver, and (3) the external signal line loop is shunted so that other teletypewriters in that loop can communicate without being affected by the operation of the local teletypewriter.

4.07 If the rotary power switch is placed in the line mode—the control knob turned to the LINE position—the line relay is energized. This causes the normally closed contacts A to open and the normally open contacts B to close. Thus, the normally closed contacts A and the normally open contacts B are conditioned such that (1) the external signal line loop is united with the selector magnet driver, and (2) the local teletypewriter is placed in the external signal line loop, so that it can communicate with

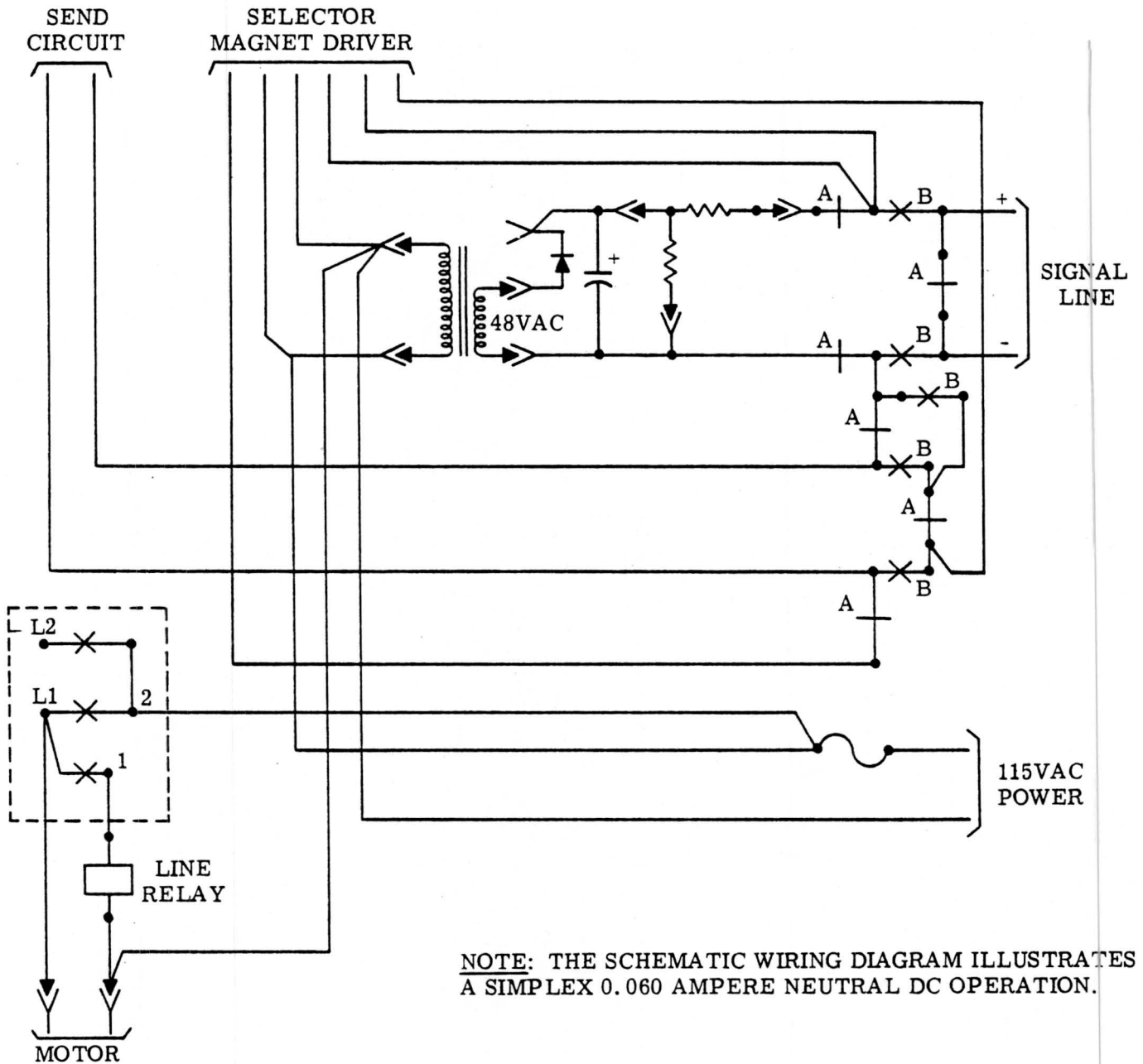

**NOTE:** THE SCHEMATIC WIRING DIAGRAM ILLUSTRATES A SIMPLEX 0.060 AMPERE NEUTRAL DC OPERATION.

Figure 17 - Rotary Power Switch and Local Power Supply Circuit

other teletypewriters in that loop. With battery on the signal line, any transmission from the keyboard or tape reader, when provided, will cause the typing unit distributor to send start-stop signals to other teletypewriters in the

external signal loop. Also, the local teletypewriter is able to receive, through the typing unit selector, the start-stop signals transmitted from other teletypewriters in the external signal line loop.

5. CALL CONTROL UNIT -CIRCUIT SWITCH-  
ING SERVICE

OPERATION

A. General

5.01 The call control unit provides the facilities for operating a teletypewriter in a circuit switching network. The facilities include means of initiating or accepting, and controlling calls over telegraph loops utilizing neutral signaling. Provisions are made for including a polar adapter. In the following discussion, refer to wiring diagrams 6481WD, 7227WD or 7267WD, as applicable.

5.02 A selector magnet driver circuit delivers marking signals of 0.500 ampere and spacing signals of essentially 0 ampere to the associated selector magnet. The signals trigger the selector magnet driver circuit at about half the current level for normal (0.060 ampere mark) neutral signals. In teletypewriters modified for polar operation, the signal is applied to the polar-to-neutral converting circuits and then to the selector magnets.

5.03 The operator's controls consist of four pushbuttons for selecting the various operating conditions. They are designated REQUEST, CONN, LCL, and DISCONN. Each pushbutton except DISCONN contains an internal lamp to provide a visual indication.

P Idle Signal Line

5.04 When the telegraph loop is quiescent (positive current of 0.005 ampere applied through the designated terminal), the teletypewriter is idle with motor off and all visual indicators extinguished.

C. Request Circuit

5.05 Operation of the REQUEST pushbutton shunts the major portion of the loop resistance, causing loop current to increase to 0.060 ampere. The REQUEST lamp lights and the motor turns on. The lamp is extinguished when the pushbutton is released or when a connection is made. The motor turns off when the REQUEST pushbutton is released before a connection is made.

D. Connect Circuit

5.06 The exchange facilities acknowledge the request signal by connecting a register unit to the calling position's telegraph lines. A register attached signal is transmitted to the calling station. This signal is a reversal of loop current, which lights the CONN lamp and extinguishes the REQUEST lamp. The calling station may then proceed, by tape, to send the prefix and call numbers of the called subscriber to the register. The register stores the characters and then proceeds to set up the connection. If a connection can be made, the register seizes the called station, turning on its motor and lighting the CONN lamp by reversing the loop current from positive to negative. The register then transmits the character WRU to the called station, tripping its answer-back. As the answer-back is transmitted, the register compares it with the stored call number to insure that the correct subscriber was reached. If the comparison indicates a correct connection, the register releases from the circuit. Transmission of traffic may now proceed using line signals of 0.060 ampere for mark and zero current for space.

E. Disconnect Circuit

5.07 When transmission has been completed, the operator at either station may release the connection by depressing the DISCONN pushbutton which causes an open line (zero current). The exchange initiates a disconnect at the distant station by reversing the loop current. Within three seconds, and with the DISCONN pushbutton depressed, the local motor turns off and the CONN lamp is extinguished. The idle condition is restored.

F. Remote Disconnect Circuit

5.08 When the called station initiates a disconnect, the exchange reverses the loop current at the local station to positive and the station is restored to idle as above.

G. Busy Signal

5.09 In the event the distant station is busy, the register transmits the designated characters to the calling station, initiates a disconnect, and releases the connection.

## H. Local Circuit

5.10 Operation of the LCL pushbutton places the teletypewriter in an offline operating mode. The associated lamplights giving a visual indication of the condition. The teletypewriter is restored to idle when the DISCONN pushbutton is depressed. A call can be initiated, without first disconnecting, by depressing the REQUEST key. If a call is received while the teletypewriter is in LCL, a time interval of not more than 2.6 seconds will elapse during which time an audible alarm (buzzer) is sounded. The teletypewriter automatically switches to the call-connected condition and lights the CONN lamp.

## ANALYSIS OF CIRCUITS

### A. Selector Magnet Driver

5.11 The selector magnet driver is described in Paragraphs 2.37 through 2.41. It is illustrated schematically in Figure 8.

### B. Motor Delay Timer

5.12 The motor delay timer is described in Paragraphs 2.42 through 2.48. It is illustrated schematically in Figure 9.

### C. Polar Adapter

5.13 The polar adapter that may be used with the call control unit for circuit switching service is described in Paragraphs 2.49 through 2.99.

### D. Request Circuit (Figure 18)

5.14 This circuit consists of a binary with a line input amplifier. The binary consists of transistors Q2 and Q3 and associated components. The low pass filter or delay network is made up of R5 and C1. The line input amplifier consists of Q1 and associated components and is connected to the binary through a low pass filter or delay network, which is used to suppress line noise. Input to the binary from the filter through R6 turns the request circuit on. One other control input is available, through resistor R15 which turns the request off when the set is connected.

5.15 When transistor Q2 is in conduction, its collector is near neutral potential. Current will then flow through Q2, R11, S3-1, S3-2, and R27. Current also flows from +18 volts

through R8 and CR9 to the collector of Q2. The base of Q3 is held at +0.8 volts with respect to the collector of Q2, due to the current flow through CR9. The base of Q3, therefore, is slightly positive with respect to neutral, and Q3 is turned off. With Q3 off, its collector is negative and base current to Q2 is supplied through a low pass filter consisting of R9, R10 and C3 which holds Q2 in conduction.

5.16 When transistor Q3 is in conduction, the request circuit is on and the Q3 collector is very near neutral. Current flows through Q3, K1, XDS-1 and R27. Since the collector of Q3 is near neutral, current flow through R7 and R9, and R10 produces a positive potential at the base of Q2 which holds Q2 off. With Q2 off, base current for Q3 flows through CR9, R11, S3-1, S2-3, and R27, holding Q3 in conduction.

5.17 When an input current of less than 0.008 ampere flows from terminal T8 across CR4 to neutral, a potential of -0.8 volts is developed across CR4, and holds Q1 off. The collector of Q1 becomes positive. Current flows through R4 and R5 to charge C1 towards +18 volts. When sufficient voltage is developed across C1, the base of Q2 is back-biased through R6. Transistor Q2 turns off and Q3 turns on if a negative potential is connected to its base. Back-bias to the base of Q2 is then supplied by the voltage divider R7, R9 and R10, and the positive potential across R6 is no longer required to hold Q2 off. Should more than 0.008 ampere flow across CR4 from terminal T8 to neutral, a potential of +0.8 volt will develop across CR4 turning on Q1. The Q1 collector then goes to neutral.

5.18 If a negative signal is applied to the side of R15 opposite the base of Q2, sufficient current flows to forward-bias the base of Q2 and bring it into conduction. Q3 will turn off and supply sufficient base current through R9 and R10 to hold Q2 in conduction. The negative signal at R15 may now be removed, and Q2 will remain in conduction.

5.19 With the request circuit on, Q3 is in conduction, base current for Q3 flows through R11 and CR9. By operating the DISCONNECT pushbutton, contacts S3-1 and S3-2 open the current path. Q3 will then turn off and Q2 will turn on. Collector current does not flow in Q2, but its collector is near neutral, holding Q3 off.

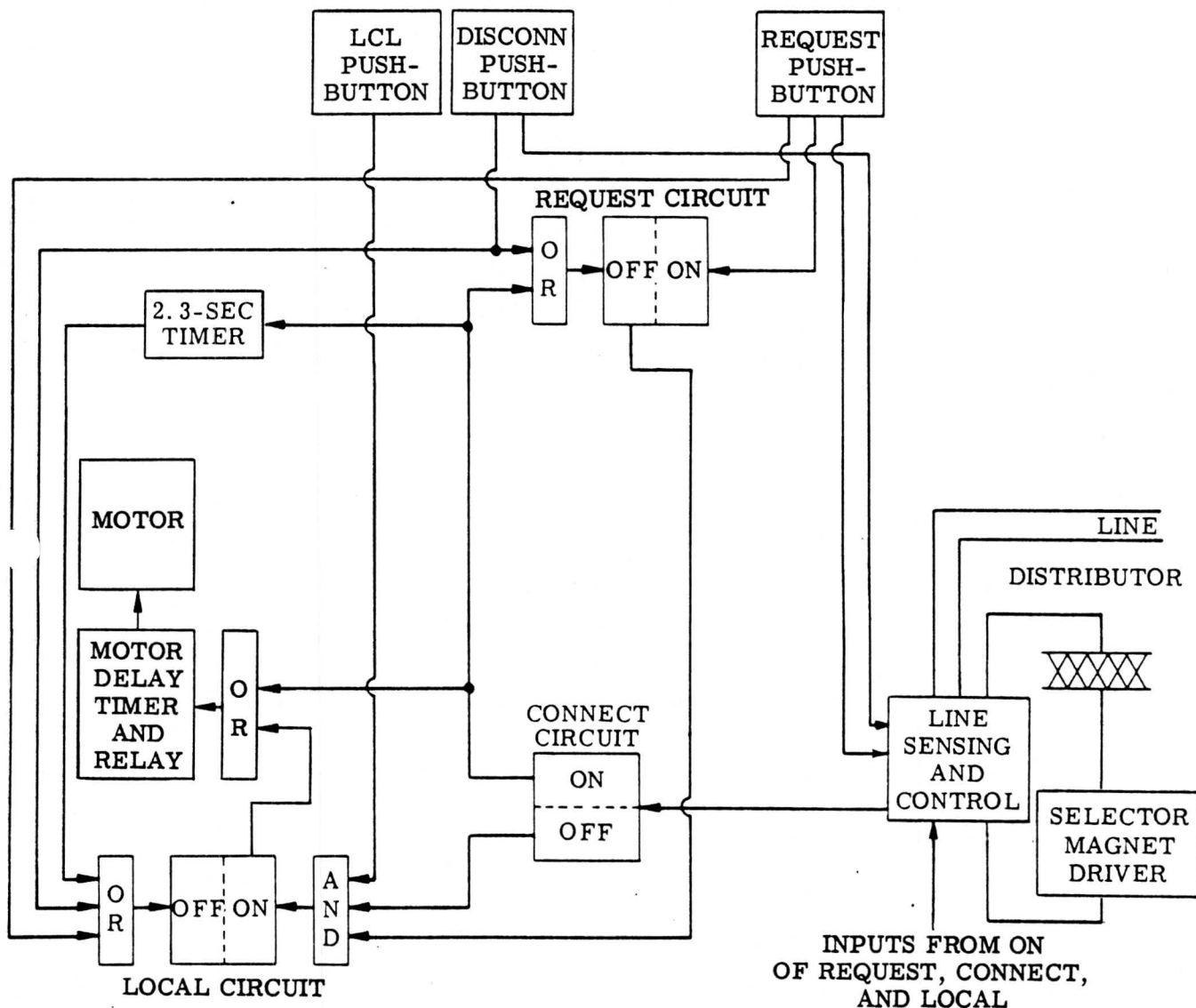

Figure 18 - Block Diagram of Control Circuits

## E. Connect Circuit (Figure 18)

5.20 This circuit consists of a binary ( $Q_4$  and  $Q_6$ ), one side of which is driven by an emitter follower. The only control input used is connected to the emitter follower through  $R_{12}$  and  $R_{13}$ .  $C_2$  and  $R_{12}$  form a low pass filter or delay network. The signal delay in the network is approximately 0.02 second. The control is by the signal line only and no positive local controls are available. A single passive control, consisting of  $R_{28}$  and  $CR_3$  is used for low paper conditions.

5.21 Emitter follower  $Q_5$  controls the base of  $Q_4$ . If  $Q_4$  is in conduction, its collector is near neutral. The voltage divider,  $R_{17}$

and  $R_{18}$ , holds the base of  $Q_6$  positive and off. The collector of  $Q_6$  is negative and the base of  $Q_5$  is held slightly negative through  $R_{20}$  and  $R_{21}$ . Since  $Q_5$  is an emitter follower, its emitter is at the same potential as its base. With its emitter at a negative potential,  $Q_4$  is held on.

5.22 When the connect circuit is on,  $Q_6$  is in conduction and its collector is near neutral. The voltage divider consisting of  $R_{19}$ ,  $R_{20}$  and  $R_{21}$  holds the base of  $Q_5$  (and therefore the emitter) positive. With the emitter of  $Q_5$  positive, the base of  $Q_4$  is back-biased and  $Q_4$  is off. The collector of  $Q_4$  will then be negative. Base current for  $Q_6$  flows through  $R_{16}$  and  $R_{17}$ , holding the connect circuit on.

5.23 To control the connect circuit, a high voltage must be developed at the junction of CR1 and CR2. This voltage will be approximately  $\pm 200$  volts. If a +200 volt signal is present, the base of Q5 is biased positive and Q4 will turn off, turning on Q6. If a -200 volt signal is present, the base of Q5 is negative and Q4 will turn on, turning Q6 off. An input signal at or near neutral does not have any effect on the connect circuit and it will remain in its previous state.

5.24 The base of Q5 is protected against excessively high voltages by transistor operation or by CR11. If a -200 volt signal is present, the voltage at the base of Q5 will fall, and force its emitter to follow. When the emitter of Q5 becomes negative with respect to neutral, Q4 turns on. With Q4 in conduction, its base potential is held close to the emitter potential. Therefore, the base cannot go more negative than -0.4 volt. This action also holds the base voltage of Q4 within -0.4 volt of its emitter. Therefore, the base voltage of Q5 cannot become more negative than approximately -0.8 volt. If a +200 volt signal is present at the input, the base of Q5 will become positive. Diode CR11 is a forward-biased diode to positive base voltages, and will limit the voltage on the base of Q5 to approximately +0.8 volts. Therefore, under the severest input conditions, a voltage swing of more than  $\pm 0.8$  volt is not expected.

5.25 Resistors R24, R25, and R26 and capacitor C5 are used when a polar converter is employed. As they are connected in 7267WD and 6481WD, they have no effect upon the operation of this circuit.

#### F. Local Circuit (Figure 18)

5.26 This circuit consists of a binary and a unijunction transistor timer. There are four input controls available. Operation of the binary is the same as that of the request circuit. The local circuit is turned on (Q9 on) by means of the LCL pushbutton. If contact S2-1 is closed, base current is supplied to Q9 through R37 and R38. This base current causes Q9 to turn on, turning Q8 off. If the anode of CR14 is neutral, current flowing through R38 goes through the diode and does not reach the base of Q9. This allows the local circuit to be turned on only when the connect circuit is off. If the anode of CR3 is also neutral, current from R38 flows through both CR14 and CR13 keeping the local circuit off when the teletypewriter is in a request condition. The local circuit may be turned off by two inputs consisting of two pushbutton

contacts in series. The contacts are S2-1 of the REQUEST pushbutton and S2-3 of the DISCONN pushbutton. If the local circuit is on, the base current for Q9 flows through these contacts. Operating either of these pushbuttons will turn Q9 off.

5.27 The unijunction transistor output also turns the local circuit off. The unijunction transistor Q7 is a breakdown device. If the voltage at C9 is more negative than approximately -8 volts, the resistance of the junction between the lead connected to C9 and the lead connected to R35 is high. When the voltage at C9 becomes more positive than approximately -8 volts, this junction will become very low in resistance and C9 will recharge through R35. The increase in current through R35, while recharging C9, will cause an increase in the voltage drop across R35. This positive pulse is coupled through C10 and CR17 to the base of Q9, causing it to turn off and Q8 to turn on. The local circuit is then off. As capacitor C9 is recharged, the junction obtains a high resistance.

5.28 Capacitor C9 may be discharged toward neutral or held at approximately -18 volts through R32 and R33. If the input to R32 is negative (connect circuit off), the capacitor will be held at -18 volts. If the input to R32 is near neutral (connect circuit on), capacitor C9 will discharge through R32 and R33 toward neutral. At the end of a 2.3 second interval, the voltage at C9 will be approximately -8 volts and the unijunction will break down and turn the local circuit off as previously described.

#### G. Circuit Interconnections (Figures 18, 19 and 20)

5.29 To turn on the request circuit the REQUEST pushbutton must be operated. This connection is shown in Figure 18. Depressing the REQUEST pushbutton presents the proper signal to the line so that the request is recognized.

5.30 When the connect circuit is operated by reversing the polarity of the input signal from the line, the request circuit is turned off. The connect circuit is controlled only by the line and therefore has only one input, from the line sensing and control portion of the call control unit, as shown in Figure 18.

5.31 To turn the local circuit on, three conditions must be met. The request and connect circuits must be off and the LCL pushbutton must be operated. The connect circuit

input protects against accidental operation of the local circuit during the connected condition, which would cause an automatic disconnect. The request input also protects against accidental operation of the LCL pushbutton.

5.32 The local circuit may be turned off by operating the DISCONN pushbutton or the REQUEST button, or through the 2.3 second timer. The REQUEST and DISCONN pushbuttons provide local control of the circuit, while the timer provides automatic control. The timer is controlled by the connect circuit, which is in turn controlled by the line. The timer will continue to oscillate as long as the connect circuit is on, but only the first timing pulse is required to turn off the local circuit.

5.33 When either the connect or local circuit is on, the motor delay timer output is operated. The contacts of the motor delay relay associated with the timer are used to turn on the motor of the teletypewriter. When either the local or connect circuit turns off, the motor delay timer holds the relay on for approximately 0.550 second.

#### H. Idle Line Condition (Figures 19 and 20)

5.34 In the idle line condition all relays and lamps are off. To accomplish this transistors Q3, Q6, and Q9 are off and Q4, Q2 and Q8 are in conduction. The output transistor of the motor delay timer is off and the selector magnet driver is marking. The signal loop is a 240 volt source furnishing 0.060 ampere. In the idle condition the call control unit supplies 43,800 ohms of local resistance to the signal loop. The flow of loop current in this condition shown in Figure 19. Current flows from TB8, the positive idle terminal, across CR4, through R1 and CR1 in parallel with the base emitter junction of Q4 and Q5, R13 and R12 to terminal TB9.

5.35 The loop current develops a positive potential at point (A) in Figure 19 holding Q1 on. The collector of Q1 is shorted to ground through contacts S1 (4-5). Therefore, no signal may be developed at the collector unless the REQUEST pushbutton is depressed. The loop current develops approximately -200 volts with respect to neutral at point (B). This potential holds Q4 in conduction and the connect circuit off.

5.36 The selector magnet driver is supplied 0.07 ampere locally to hold the selector magnet energized. This blinding current is sup-

plied through R23 from +18 volts and through a resistor in the 120 volts auxiliary power supply, through CR3 in the power supply. This current flows through contacts K2-1 and K3-1, the sending apparatus (keyboard signal generator and distributor) through the selector magnet driver and to neutral.

#### I. Initiating a Call (Figures 19 and 20)

5.37 A call may be initiated with the teletypewriter or local condition. To initiate a call, the REQUEST pushbutton must be depressed. Depressing this key performs four functions. Contact S1 (1-2) opens and turns off the local circuit. Contact S1 (4-5) opens and removes the short to neutral across the Q1 collector. Contact S1 (5-6) closes shorting out the local loop resistance. This allows the loop current to rise to 0.060 ampere. Contact S1 (1-3) closes and provides negative battery to the base of Q3 and the collector of Q2. The last three contacts must operate in a sequence to complete the request function, as explained below.

5.38 Loop current then flows from TB-8, through CR4, contact S1 (5-6), CR1 to TB-9. Shorting out the local loop resistance causes the voltage at point (A) to rise to neutral with no effect upon the state of the connect circuit as explained above.

5.39 As the REQUEST pushbutton is depressed, contact S1 (4-5) opens, removing the shunt from the collector of Q1 to neutral. This allows the collector to go positive. C1 charges towards +18 volts and the base of Q2 is back-biased through R6. Q2 turns off. As the pushbutton is depressed further, contact S1 (1-3) closes and -18 volts is applied to the base of Q3. Q3 conducts, turning on the K1 relay and the REQUEST lamp. Contact S1 (5-6) closes, allowing the loop current to increase to 0.060 ampere. The base of Q1 is forward-biased and Q1 turns on with no effect on Q2.

5.40 With Q3 in conduction and its collector near neutral, the junction of R37 and R38 in the local circuit is held near neutral through CR13 as the LCL pushbutton is operated. The local circuit can not be turned on. The near neutral condition at the collector of Q3 results in the base of Q3 in the motor delay timer being reversed-biased. The transistor is turned off and its collector is negative, causing the base of Q2 in the timer to be forward-biased. Q2 then conducts, and the motor control relay energizes, turning on the teletypewriter motors.

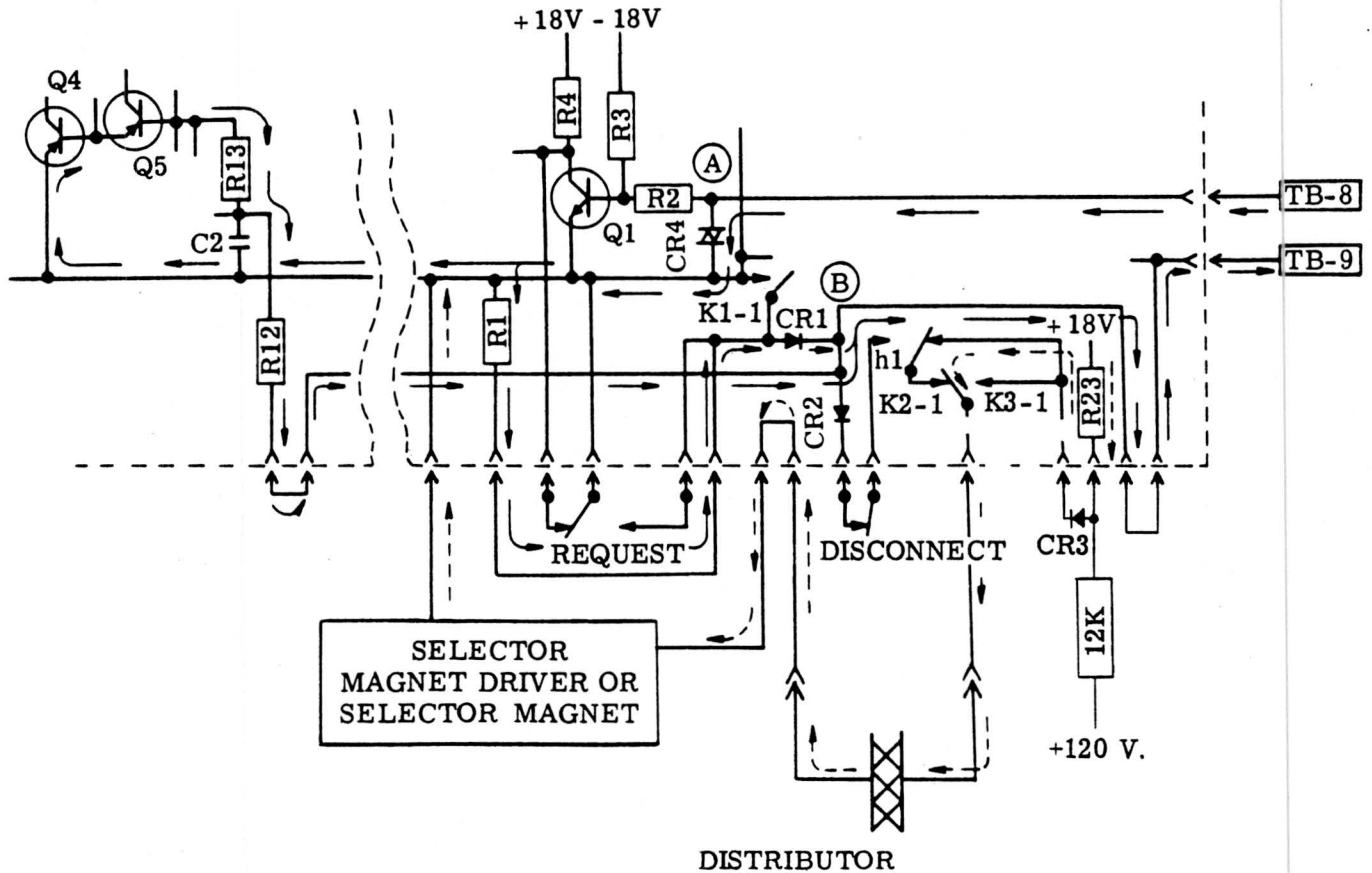

Figure 19 - Control Circuits in Idle Condition

5.41 If the REQUEST pushbutton is released at any time before the connect circuit is turned on, the teletypewriter will revert to the idle line condition.

#### J. Call Connection (Figures 18 and 20)

5.42 If a call is initiated locally, current in the loop is 0.060 ampere. When the loop polarity is reversed by the exchange, current flow is from TB9 to TB8. Diode CR1 becomes reverse-biased, stopping any current flow except that through R12 and R13. This current flow turns off Q4 and turns on the connect circuit. With Q6 in conduction, the K2 relay operates and the CONN lamp lights. The transfer contacts K2-1, then switch and allow loop current of 0.060 ampere to flow through the distributor and selector magnet driver as shown in Figure 20. The loop current then flows from TB9 through CR2, the contacts of K2-1 and K3-1, keyboard signal generator and distributor, the selector magnet driver, and CR4 to TB8.

5.43 With Q6 in conduction, CR15 is forward-biased and will turn on the output transistor (Q2) of the motor delay timer. The motor control relay operates, closing contacts K4, turning on the motors. Q4 is cut off and its collector is negative. Feedback from the collector of Q4 to the base of Q2, through R15, turns off the request circuit. The K1 relay releases and the REQUEST lamp extinguishes. The K1-1 contact opens, but does not have any effect upon loop current flow, since it is not in the current loop. The junction of R37 and R38 is held near neutral from the collector of Q6 through CR14 and prevents operation of the local circuit.

#### K. Remote Connection (Figures 18, 19 and 20)

5.44 The teletypewriter may be connected remotely when it is in the idle line or local condition. The incoming call causes the exchange to reverse the loop polarity from that shown in Figure 19. This causes the potential at the junction of CR1 and CR2 to change

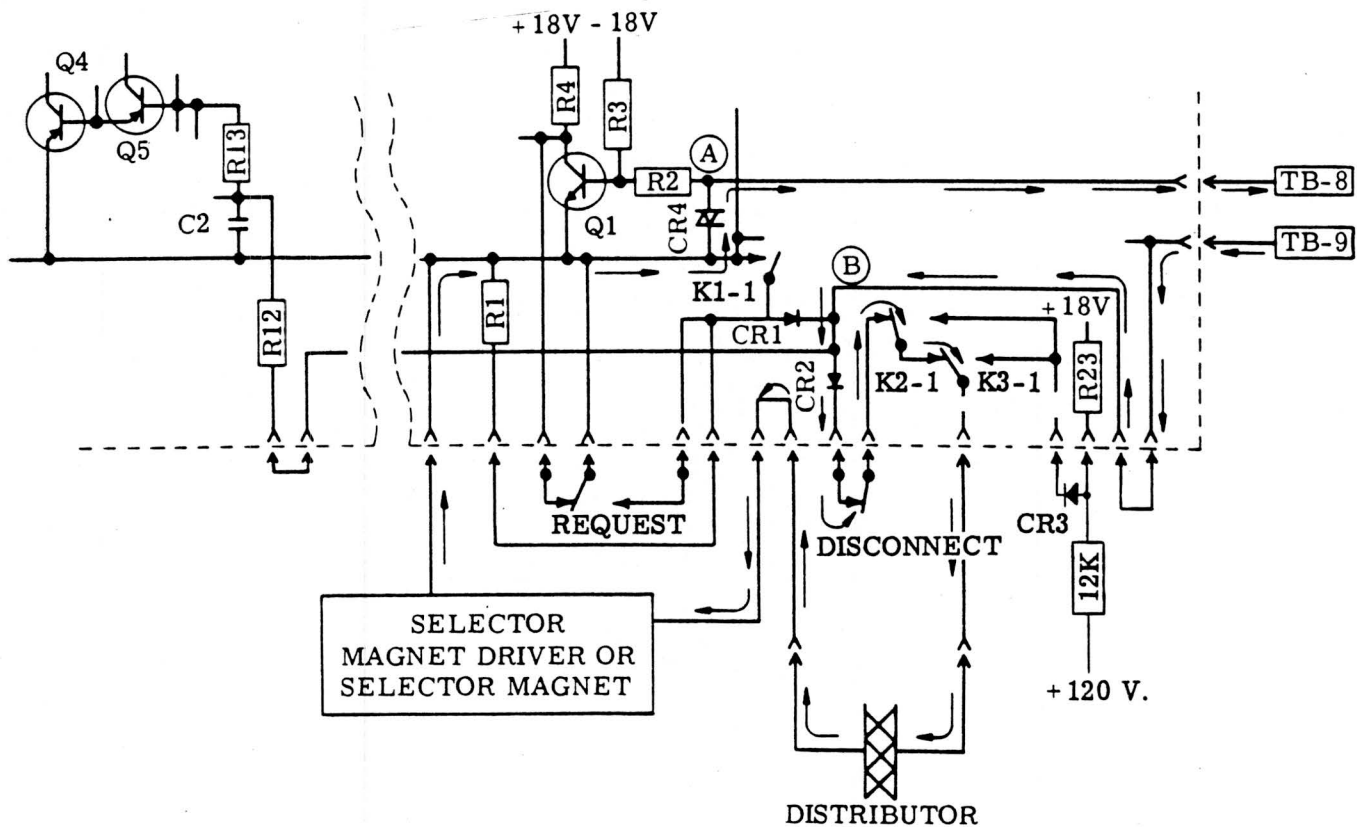

Figure 20 - Control Circuits in Connected Condition

from -200 volts to approximately +200 volts. This potential causes the connect circuit to operate as described above.

5 If the paper in the teletypewriter becomes low and the low paper contacts operate, the junction of R12 and R13 is not allowed to become positive. Q4 may not be turned off and a connection cannot be made. If low paper occurs during a call, the teletypewriter remains in the connected state since zero potential at the junction of R12 and R13 will not affect the connect circuit. A disconnect occurs in the normal manner, since CR3 will be back-biased to a negative potential at the junction of R12 and R13.

5.46 When a call is initiated locally and a low paper condition exists, the normal sequence of events occur until a connection is attempted. When the exchange cannot connect, it reverses the loop polarity and the teletypewriter returns to the idle condition.

L. Call Disconnect (Figures 18 and 19)

5.47 Operation of the DISCONN pushbutton while in the connect condition, opens the signal loop. When the exchange recognizes the break, it reverses the loop polarity. The reverse polarity is blocked by CR2 and current flows through CR1 along the same path shown in Figure 19. At point (B) -200 volts is developed by current flow as described in 5.35. This potential causes the connect circuit to turn off. The CONN lamp is extinguished and the K2 relay releases. The K2-1 contacts return to the blinded condition and the teletypewriter stops running open. The input to the motor delay timer is negative and the timer times out. After 0.550 second the motor control relay releases and the motor turns off. This delay period allows the teletypewriter clutches to latch.

M. Remote Disconnect

5.48 The operation of the circuits and the loop paths are the same as those described in 5.47. The DISCONN pushbutton is not depressed

locally, but the signal conditions appear identical to the call control unit.

#### N. Local Offline Operation

5.49 If the teletypewriter is in the idle line condition, operation of the LCL pushbutton causes the local circuit to operate (Q8 turns on). If the unit is in either the request or connect condition, CR13 or CR14 prevents operation of the local circuit. When the local circuit operates, the K3 relay operates and the LCL lamp will light. Contact K3-1 of the relay shorts out contacts K2-1 in the signal loop. Current in this loop will then flow through R23, K3-1, the keyboard and the selector magnet driver, to neutral. CR16 is forward-biased, causing the output transistor of the motor delay timer to turn on. The motor control relay operates and the motor starts. The associated apparatus are now ready for offline operation.

5.50 To revert back to the idle line condition, the DISCONN pushbutton is depressed. Contact S3-2 opens and turns off the local circuit as previously described. A call may then be initiated in the local condition in the usual manner. When the REQUEST pushbutton is de-

pressed, contact S1-2 opens and turns off the local circuit in the same manner as when the DISCONN pushbutton is depressed.

5.51 If an incoming call is received while the teletypewriter is in the local condition, the action of the circuit is the same as that described in 5.42 and 5.44. The K2 relay operates to shunt the line through the sending components of the set and the selector magnet driver, but this operation cannot be accomplished, since the K3-1 contact has shorted the K2-1 contact out of the circuit. Operation of the K2-2 contact completes the 117 volt ac circuit to the buzzer causing it to sound.

5.52 With the connect circuit on, the collector of Q6 is near neutral. This causes the timer to start. At the end of a 2.3 second period, a positive pulse from the timer is coupled to the base of Q9, through C10 and CR17. This pulse causes the local circuit to turn off. The LOCAL lamp is extinguished and the K3 relay is released. The K3-1 contact shorts the signal loop through the sending and receiving apparatus of the set. The K3-2 contact opens and the buzzer turns off. The teletypewriter is now in the connect condition.

32 AND 33 COVER

ADJUSTMENTS, LUBRICATION, AND DISASSEMBLY AND REASSEMBLY

CONTENTS	PAGE
1. GENERAL . . . . .	1
2. ADJUSTMENTS . . . . .	1
Dial to cover . . . . .	3
Knob to bezel . . . . .	3
3. LUBRICATION . . . . .	4
Cover . . . . .	5
Lid . . . . .	5
4. DISASSEMBLY AND REASSEMBLY . .	6

1. GENERAL

1.01 This section is issued to provide adjustment, lubrication, and disassembly and reassembly information for the 32 and 33 cover and to present the information as a separate section.

1.02 A plastic cover such as is shown in Figure 1 provides a decorative and protective enclosure for the typing unit, keyboard, and call control unit. A lid, which is spring detented in its open position, may be raised to gain access to the typing unit for replenishing such items as paper and ribbon. A window permits viewing the copy and provides a cutting edge for tearing paper or forms. Slots at the rear of the cover hold the

paper roll spindle. Mounting slots are provided for a copy holder. A nameplate (Figure 2) is mounted at the front.

1.03 The cover is mounted at its outer edges on a cast subbase (Figure 2) which serves as a foundation for the keyboard, typing unit, and call control unit. Rubber vibration isolators support the typing unit.

1.04 Reference to "left," "right," "front," or "rear," etc, consider the cover to be viewed from a position where the lid is up and the nameplate position is facing toward the viewer.

2. ADJUSTMENTS

2.01 In the adjustments covered in this section, location of clearances and position of parts are illustrated by line drawings. Requirements and procedures are set forth in the texts that accompany the line drawings.

2.02 If the mounted cover and/or other parts are removed to facilitate the making of an adjustment, replace it and/or the other parts after making the adjustment. Recheck any adjustments that may have been affected by the removal of the cover and/or other parts.

2.03 Unless specifically stated otherwise, make screws or nuts friction tight to make an adjustment, and tighten them securely once the adjustment has been made.

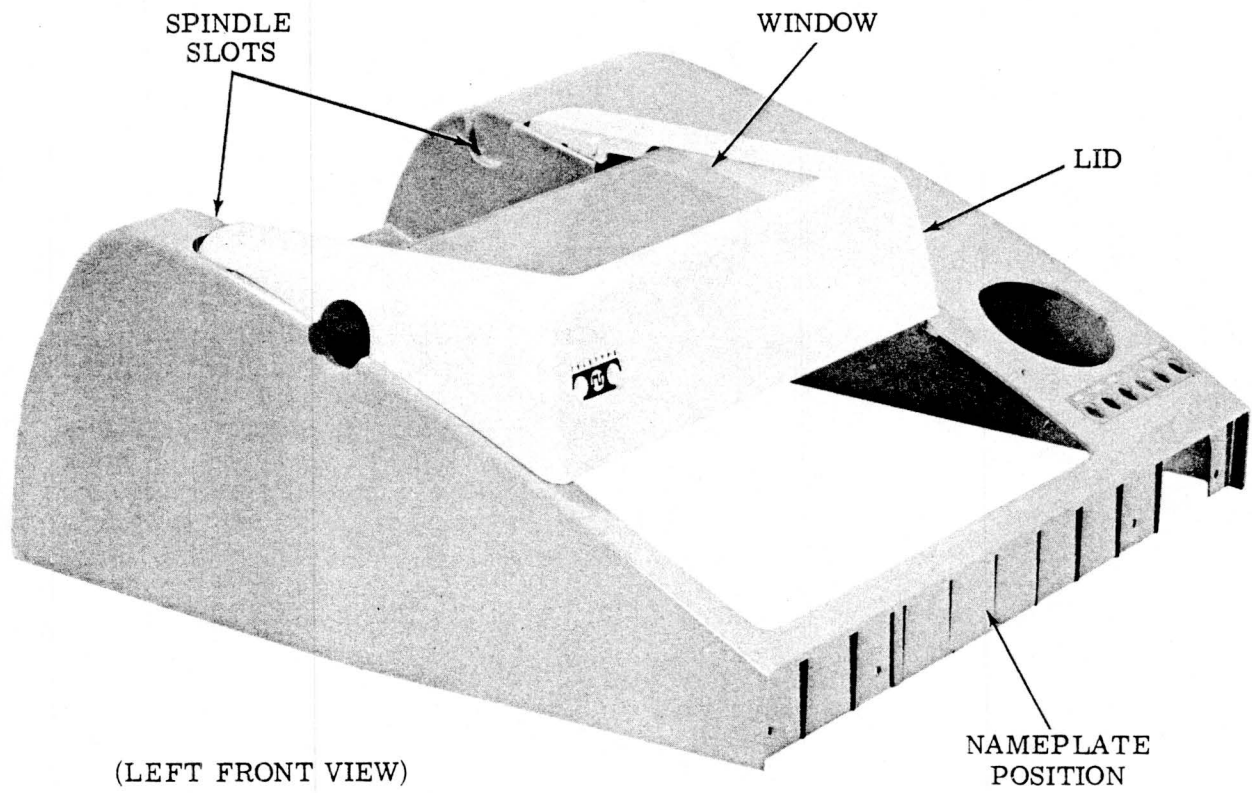
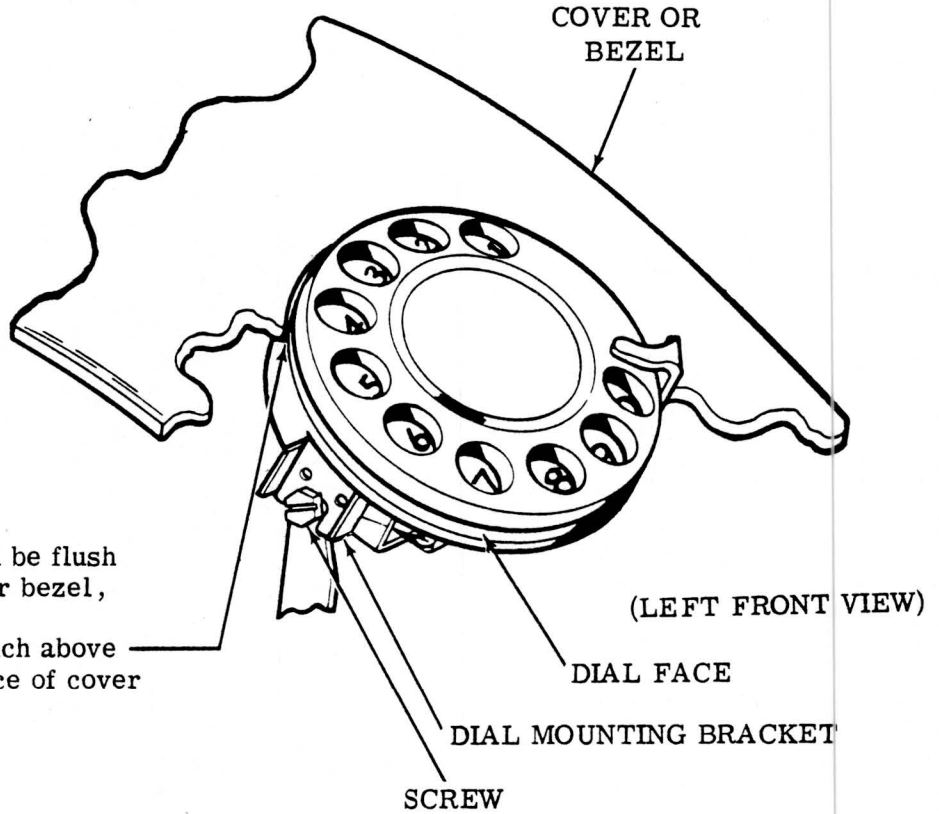

Figure 1 - Cover

2.04 Dial and Knob



DIAL TO COVER

Requirement

The numbered dial face shall be flush to outside surface of cover or bezel, within  
 1/16 inch below---3/32 inch above  
 and parallel to outside surface of cover or bezel, within  
 1/16 inch  
 as gauged by eye.

To Adjust

With dial mounting bracket screws loosened, position the dial face.

KNOB TO BEZEL

To Check

Fully seat the TP181824 knob on the power switch.

Requirement

Min Some---Max 1/8 inch  
 between the bottom of the knob and the face of the bezel.

To Adjust

Remove the TP181824 knob and the cover. (See Part 4 of this section for instructions.) Loosen screws and position the bracket. Recheck the "Requirement."

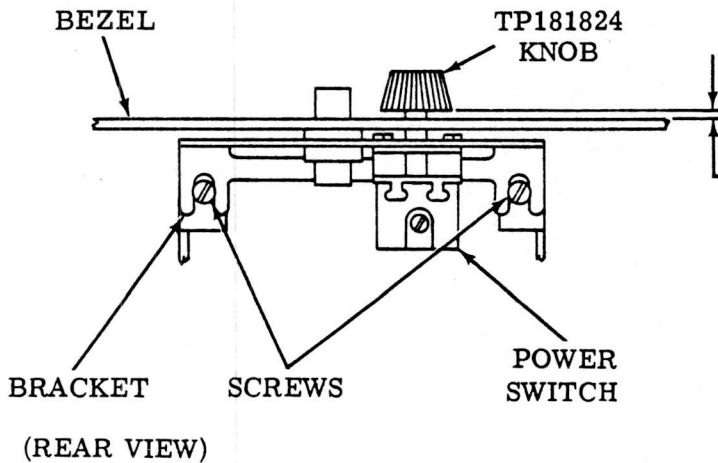

## 3. LUBRICATION

3.01 The general lubrication area is illustrated by a photograph. The specific points to receive lubricant are indicated on a line drawing with appropriate textual instructions. The line drawing and textual instructions follow the photograph and are keyed to the photograph by a paragraph number.

3.02 Lubricate the cover as indicated. Do not allow any lubricant to drop onto any adjacent parts. Use KS7470 oil where oil is specified.

3.03 Lubricate the cover before placing it into service or prior to storage. After a short period of service, relubricate it to be sure that no areas have been missed. Hereafter, lubricate the cover at regular intervals as indicated below:

OPERATING SPEED (WORDS PER MINUTE)	LUBRICATION INTERVAL
60 or 66	1000 hr* or 1 yr**
100	500 hr* or 6 mo**

\*Station Set operating hours.

\*\*Whichever comes first.

3.04 The textual instructions that accompany the line drawing consist of abbreviated directions, specific lubrication points, and parts affected. The meanings of the abbreviated directions (symbols) are given below:

SYMBOL	MEANING
D	Keep dry—no lubricant permitted.
OSD	Oil sparingly or leave dry.

**CAUTION: DO NOT USE ALCOHOL, MINERAL SPIRITS, OR OTHER SOLVENTS TO CLEAN ANY PLASTIC PARTS OR PARTS WITH PROTECTIVE DECORATIVE FINISHES. NORMALLY, A SOFT, DRY CLOTH SHOULD BE USED TO REMOVE DUST, OIL, GREASE OR OTHERWISE CLEAN PARTS OR SUBASSEMBLIES. IF NECESSARY, A SOFT DAMP CLOTH WITH SOAP OR A MILD DETERGENT MAY BE USED. AFTERWARDS, RINSE EACH CLEANED PART OR SUBASSEMBLY WITH A SOFT, DAMP CLOTH, AND BUFF WITH A SOFT, DRY CLOTH.**

3.05 Cover

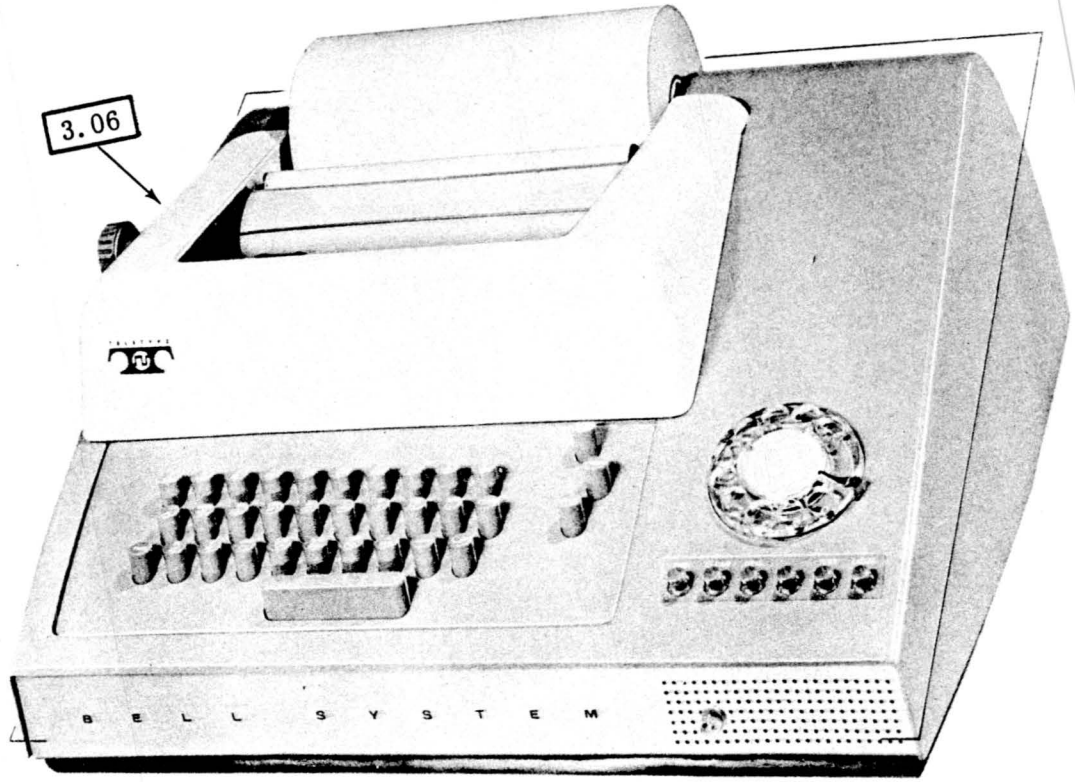

(RIGHT FRONT VIEW)

Cover Lid

3.06 Lid

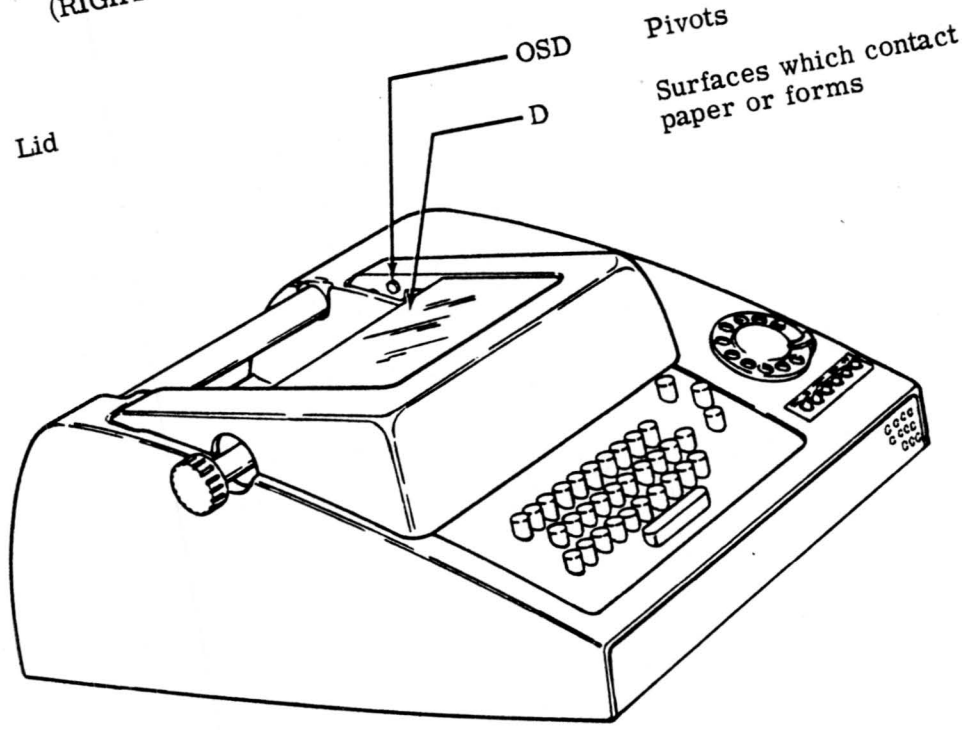

Pivots  
Surfaces which contact  
paper or forms

4. DISASSEMBLY AND REASSEMBLY

4.01 Before beginning disassembly, remove connectors from external receptacles (power source, data set, etc).

4.02 Remove paper and paper roll spindle. Remove bezel, if used, on call control unit by removing two mounting screws. Remove either the volume control knob, if used, or the power switch rotary knob, if used, by pulling forward. Remove the nameplate by pulling it down and out. Remove the platen knob used on friction feed typing units by pulling it to the left. On sprocket feed typing units, remove a platen knob screw first, then remove the platen knob by pulling it to the left.

4.03 Remove seven TP125002 mounting screws—four in the front and three in the rear of the cover (Figure 2).

Note: On Automatic Send-Receive Teletypewriter Sets, remove the screw from the left rear corner of the tape reader cover.

4.04 Gently lift the cover from the subbase and set it aside.

Note: At this point, if any disassembly of the typing unit is to take place, remove external connections (signal line, etc) from the terminal board of the call control unit.

4.05 To replace the cover, reverse the procedure used to remove it. Make sure that the keyboard, dial, etc, are properly aligned in the holes provided.

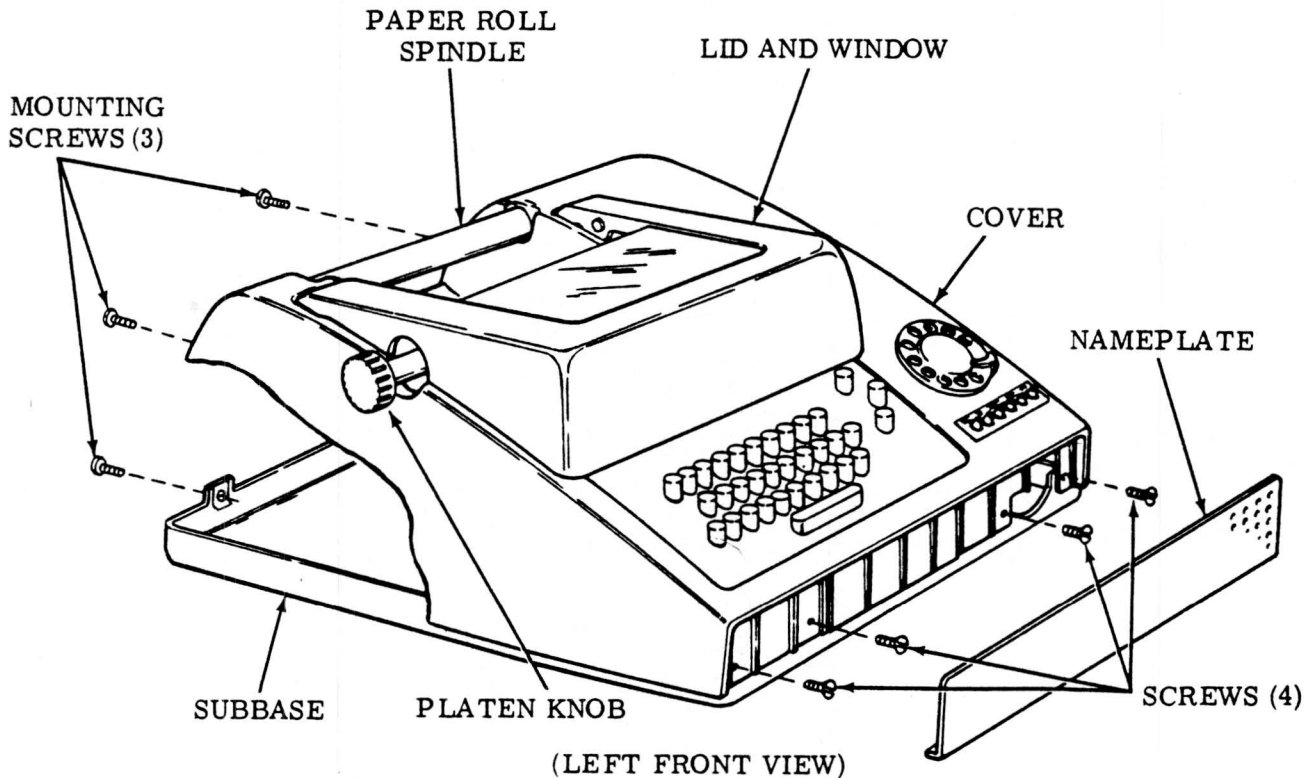

Figure 2 - Cover